



GENERAL CATALOG



CIRCULAR CONNECTORS CVBS - CVBR - CVBSG - GVJ
For Railway applications



Radiall 

 VanSystem

About Us



Radiall

Since 1952, Radiall Sa have been enabling the future through collaboration with our customers. The results are a range of innovative and award-winning products that customers trust for unrivaled repeatability and performance.

Radiall Sa are a global company with facilities around the world that specializes in manufacturing the highest quality interconnect components to support the most demanding applications.

At Radiall, you can rely on us to be the industry's global market leader.



VanSystem is a company founded in Lombardy - Italy, which has been operating since 1985 in the industrial market. Since 2015 VanSystem is a Radiall company.

Besides connectors with screw or bayonet coupling complying with the Mil-DTL-5015 standard, VanSystem designs and manufactures non-standard products for special applications.

One of VanSystem's strong points is an agile and dynamic organizational structure which enables direct and constant interaction with customers in order to meet all their requirements and build solid, long-term partnerships.

The VanSystem team's professionalism, skill and commitment are at your service to help you achieve the solution you are looking for.

VanSystem's Quality System is qualified according to ISO 9001:2015 and ISO/TS 22163:2017 IRIS Certification™ rules:2017 (International Railway Industry Standard).







Product Selection Guide - Index

Part number explanation	Pages 4-7
--------------------------------	-----------

Detailed Index	Page 396
-----------------------	----------

Find your connector in 4 steps!



 <p>INSERTS</p>	What is your Application? Define the insulating material.	Rubber or Thermoplastic type	Page 18
	What are the electrical characteristics? Choose the Arrangement	Number of contacts	Page 24
		Insert size	Page 50
		Voltage (Service Rating)	Page 50
		Current Rating	Page 50
	Do you need internal electrical insulation?	Grommet	Page 50
Do you need an alternative Insert Position?	Polarization Code	Page 60	
 <p>CONTACTS</p>	What contact do you need? Check the wire section/AWG	Standard Contacts supplied with connectors	Page 22
		Standard or Special Contacts supplied separately	Page 347
	What is your application? Define the contact type.	Contact Plating	Page 347
		Crimp Adapters	Page 362
		Coaxial Contact	Page 363
		Thermocouple Contact	Page 364
 <p>SHELLS</p>	What is your Application? Define the Shell.	Shell finishes	Page 17
		Shell type - Connector Class	Page 66
	Do you need CVBS Bayonet Connectors?	Receptacle Connectors (<i>Shell Type 00 020 02 030 03</i>)	Page 70
		In-Line Receptacle Connectors (<i>Shell Type 01</i>)	Page 128
		Jam Nut Receptacles (<i>Shell Type 07 070</i>)	Page 162
		Plug Connectors (<i>Shell Type 06 08</i>)	Page 166
		EMI Grounding Finger Connectors (<i>Shell Type 96 98</i>)	Page 200/228
		Through-Bulkhead Connector (<i>Shell Type TB</i>)	Page 268
		Dummy Receptacle Connectors (<i>Shell Type 05</i>)	Page 270
		Receptacle Connectors (<i>Shell Type 00 020 02</i>)	Page 318
or GVJ Oversize Bayonet Connectors?	Plug Connectors (<i>Shell Type 06 08</i>)	Page 332	
 <p>ACCESSORIES and CRIMP TOOLS</p>	Do you need accessories or crimp tools?	Metal Caps	Page 370
		Plastic caps	Page 374
		Panel Gaskets	Page 376
		Cable gland	Page 378
		Contact hole plugs	Page 384
		Crimp Tools	Page 385

Part number explanation

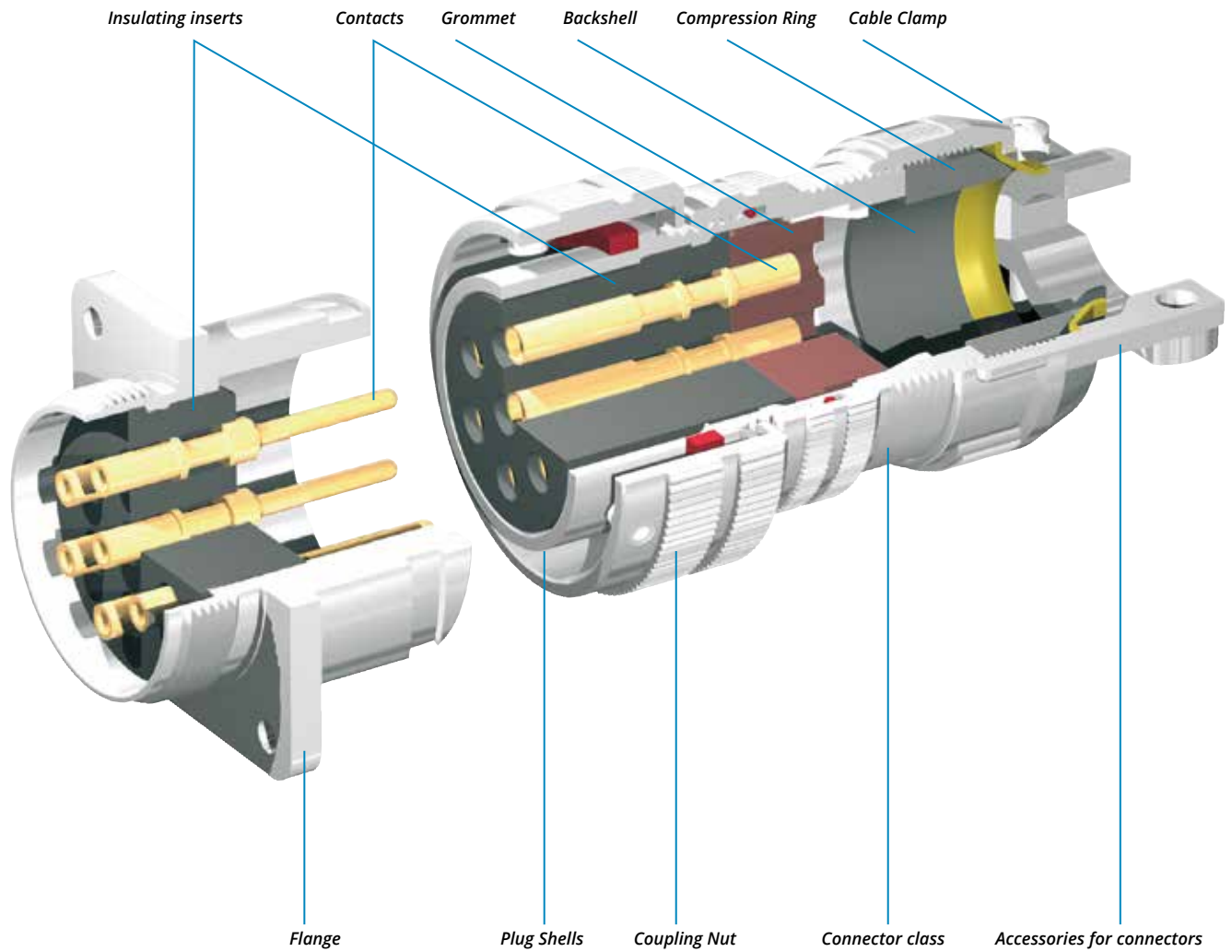

Part number explanation

P/N Sample: RF CVS 303 00DA T 20-27 S X PG16 CR CD5 F7 G N101



RF	Insulating material	-	Chloroprene rubber
		V	Fluoride rubber (Aggressive environments)
		S	Silicone rubber (-55°C ÷ 200°C)
		RF	Fire resistant rubber (EN45545 R22- R23 / HL3)
CVS	Series Code	CVS	Threaded Connector
		CVB	Bayonet Connector
		CVBS	Bayonet Connector with protected mating ramps
		CVBSG	Bayonet Connector with external insulated coating
		CVBR	Bayonet Connector roller studs - for harsh applications
		GVJ	Oversize Bayonet Connector
303	Shell Material	-	Aluminum
		303	Stainless Steel 303 (CVS - CVB)
		316	Stainless Steel 316L (CVB)
00	Shell Type	xx	Flange/Plug Shell with ramp/threaded or with nut
DA	Connector Class	xx	With backshell /Cable clamp
T	Connector Modification**	T	With plastic caps
		FF	Receptacle connector with threaded holes (to specify for 00/02/05 shell only)
		FP	Receptacle connector with through holes (to specify for 03 shell only)
		FS	Receptacle connector with countersunk holes
		GG	Rubber covered nut (CVBS and CVBR version only)
V	Insert and contacts sealed (solder only)		
20-27	Insert Arrangement	xx-xx	Size - Arrangement
S	Contact Gender	S	Socket contacts
		P	Pin contacts
X	Polarization Code**	-	No rotation
		W,X,Y,Z,Q	Rotation
PG16	Backshell Conduits size or internal thread	-	Without internal thread
		xx	Conduits size or internal thread
CR	Contact Termination	-	Solder contacts
		CR	Crimp contacts
		LC	Less contacts
		DS	PCB contacts
		CLT*	Longer contacts for grounding solder termination (CLT CR with crimp contacts)
		LT*	Grounding contact connected to the shell (LT CR with crimp contacts)
CD5	Contact Plating	-	Silver plating
		CD5	Gold plating
		CD15	Gold plating heavy
F7	Shell finishes	F4	CCF - Green passivation - conductive
		F5	Electroless nickel (<i>RoHS compliance</i>)
		F7	Black epoxy varnish (<i>RoHS compliance</i>)
		F12	Black Hard Deep Anodization - not conductive (<i>RoHS compliance</i>)
		F16	CCF - Black passivation - conductive (<i>RoHS compliance</i>)
		F26	Black Hard Anodization (<i>RoHS compliance</i>)
G	Panel Gasket	F30	colorless passivation for stainless steel (<i>RoHS compliance</i>)
		-	Without gasket
		G	With waterproof panel gasket
		G2	With shielded panel gasket
		G3	With waterproof shielded panel gasket
N101	Modification Code**	Nxx	Contacts and hole plugs (Consult our sales office)
		Sxx	Customization (Consult our sales office)

** If required

* Consult our sales office

Part number explanation - Shell type

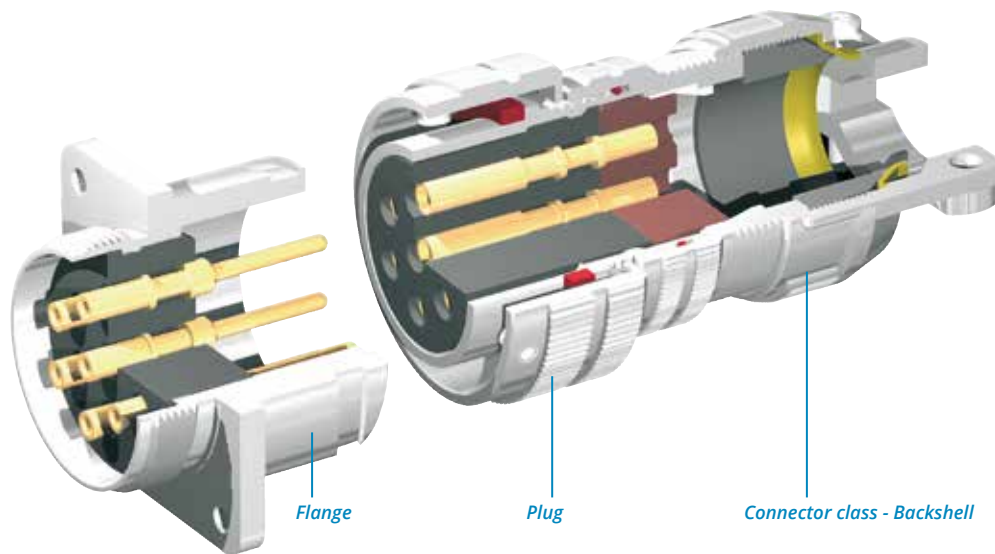

FF	FP	FS	Flange - Shell Type with ramp or threaded	
●	●	●	Shell 00	Front mounting receptacle connector able to accept rear accessories (ordered with accessories)
●	●	●	Shell 020	Front mounting receptacle connector able to accept rear accessories (ordered without accessories)
●	●	●	Shell 02	Front mounting receptacle connector unable to accept rear accessories (standard version)
●	●	●	Shell 02A	Front mounting receptacle connector non environmental (equivalent MS3102A threaded version or MS3102A..B bayonet version)
●	●	●	Shell 02R	Front mounting receptacle connector environmental seal (unable to accept rear accessories)
●	●	●	Shell 03	Rear mounting receptacle connector unable to accept rear accessories
●	●	●	Shell 03A	Rear mounting receptacle connector non environmental (equivalent MS3103A threaded version or MS3103A..B bayonet version)
●	●	●	Shell 03R	Rear mounting receptacle connector environmental seal (unable to accept rear accessories)
●	●	●	Shell 030	Rear mounting receptacle connector with thread to accept backshells
●	●	●	Shell 038	Rear mounting receptacle connector with thread to accept backshells, with 90° elbow
-	-	-	Shell 07	Rear mounting Jam Nut receptacle connector unable to accept rear accessories. Mounting is made by a front fixing-nut
-	-	-	Shell 07R	Rear mounting Jam Nut receptacle connector environmental seal, unable to accept rear accessories. Mounting is made by a front fixing-nut
-	-	-	Shell 070	Rear mounting Jam Nut receptacle connector with thread to accept backshells. Mounting is made by a hexagonal fixing-nut
-	-	-	Shell 078	Rear mounting Jam Nut receptacle connector with thread to accept back shells with 90° elbow. Mounting is made by a hexagonal fixing-nut
-	-	-	Shell 01	In-line receptacle able to accept rear accessories.
●	●	●	Shell TB	Through-Bulkhead connector
●	●	●	Shell 05	Dummy receptacle connector
●			Standard version	
●			On request	
			FF = threaded holes	FP = through holes
			FS = countersunk holes	

9	1	GG	Plug - Shell Type with coupling nut	
		●	Shell 06	Plug connector, for straight backshell
		●	Shell 61	Plug connector, for straight backshell, coupling nut rubber covered (short version)
●		●	Shell 96	Plug connector, provided with grounding finger - with straight backshell
		●	Shell 08	Plug connector, with 90° elbow
		●	Shell 81	Plug connector, with 90° elbow, coupling nut rubber covered (short version)
●		●	Shell 98	Plug connector, with 90° elbow, with grounding finger
		●	Shell 26	Front mounting receptacle connector
			Shell 65	Plug connector, for straight backshell with heavy duty coupling nut
●			Shell 965	Plug connector, provided with grounding finger - with straight backshell and heavy duty coupling nut
			Shell 265	Front mounting receptacle connector with heavy duty coupling nut
●	●		Shell 961	Plug connector, provided with grounding finger - with straight backshell, coupling nut rubber covered (short version)
●	●		Shell 981	Plug connector, provided with grounding finger - with 90° elbow, coupling nut rubber covered (short version)
●			Available	9 = with grounding finger
				1 = rubber covered coupling nut, short version
				GG = could be supplied with rubber covered coupling nut

1 Without O-ring and Grommet (non-watertight)

2 With waterproof O-ring

3 With waterproof O-ring and Grommet

CVS	CVB	CVBS	CVBSG	CVBR	GJ	1	2	3	Connector Class - backshell
●	●	●	-	●	●	A	DA	RA	Backshell having an external thread suitable for MS3057...A or C type cable-clamps
●	●	●	-	●	-	LA	LDA	LRA	Long backshell having an external thread suitable for MS3057...A or C type cable-clamps
●	●	●	-	●	-	AF		F	With backshell, MS 3057...A type cable-clamps and bushing MS 3420 (for single wire)
●	●	●	-	●	-	LAF		LF	With long backshell, MS 3057...A type cable-clamps and bushing MS 3420 (for single wire)
●	●	●	-	●	●	AC		ACF	With backshell and MS 3057...C type cable-clamps (for jacketed cable)
●	●	●	-	●	-	ACB		ACFB	With backshell, MS 3057...C type cable-clamps and bushing MS 3420A (for jacketed cable)
●	●	●	-	●	-	LAC		LACF	With long backshell and MS 3057...C type cable-clamps (for jacketed cable)
●	●	●	-	●	-	AB		ABF	With backshell and MS 3057...B type cable-clamps (for jacketed cable)
●	●	●	-	●	-	AS		ASF	With backshell and MS 3057...A type cable-clamps (for single wire)
●	●	●	●	●	●		DA..PG	RA..PG	With an internal PG thread
●	●	●	●	●	●		DA..M	RA..M	With an internal Metric thread
●	●	●	-	●	●		DA..PH	RA..PH	With a PG thread metal cable glands
●	●	●	-	●	●		DA..MH	RA..MH	With a Metric thread metal cable glands
●	●	●	●	●	-		DA..FS	RA..FS	With a special adapter for UNI4883 rubber conduits
●	●	●	●	●	-		DA..MTG	RA..MTG	With a special adapter for UNI4883 rubber conduits, with nut
-	-	-	●	-	-		DAM	RAM	With rubber coated backshell and strain relief (CVBSG series only)
●	●	●	-	●	-	AR		R	Suitable to connect single wires (when strain relief is not necessary)
●	●	●	-	●	-		AG	G	Suitable for heat shrink tubing applications
●	●	●	-	●	-		AG2	G2	Suitable for heat shrink tubing applications, with nut
●	●	●	-	●	-		ASB1	SB1	Backshell for multicore jacketed shielded cables, provided with MS 3057...C type cable-clamps (for jacketed cable)
●	●	●	-	●	-		AGV	GV	With backshell for shield hose and heat shrink tubing termination
●	●	●	-	●	-			SB	With backshell for shield hose and heat shrink tubing termination, with nut
●	●	●	●	●	-		AMK	MK	With gasket and an iris spring connected to one another by an internal ring. The iris spring is used to connect multicore jacketed cables or jacketed hoses
●	●	●	●	●	-		AWN	WN	With gasket and an iris spring connected to one another, to guarantee an excellent mechanical strain relief and water tightness
●	●	●	-	●	-		FA	FM	With backshell, MS 3057...A type cable-clamps and front gasket (for single wire)
●	●	●	-	●	-		P		Backshell for potting
●	●	●	-	●	-		AST	ST	Backshell with internal cable retention system (on request ST1/ST2 with clamps for cable diameter reduction) with an external unef thread
●	●	●	-	●	-		AST..M	ST..M	Backshell with internal cable retention system (on request ST1/ST2 with clamps for cable diameter reduction) with an internal Metric thread
●	●	●	-	●	-		AST..FS	ST..FS	Backshell with internal cable retention system (on request ST1/ST2 with clamps for cable diameter reduction) with a special adapter for UNI4883 rubber conduits
-	●	●	-	●	-		DA..PHM	RA..PHM	With quick-assembly strain relief.
-	●	●	-	●	-		DA..PHM..E	RA..PHM..E	With quick-assembly strain relief and device for connecting a shielded braid to connector shell.

● Available ● On request

General Characteristics



INSERTS

VanSystem is able to offer connectors with insulators suitable for low or high voltage with layout from 1 to 201 contacts.

They are manufactured with the following compound:

- Chloroprene rubber
- Fluoride rubber
- Silicone rubber
- Fire resistant rubber
- Thermoplastic

The inserts could be supplied with materials in accordance with EN 45545-2 specification.



SHELLS

Available in several versions suitable for all applications and manufactured in different materials and finishes:

- Aluminum alloy with different types of protection finishes according to RoHS directives.
- Stainless steel, brass nickel plated and other materials to be chosen according to the application
- Coupling nut threaded or bayonet version

The bayonet connectors are derived from the threaded series to provide faster coupling and anti-vibration resistance. In the CVB, CVBS and CVBR series the coupling system is composed of 3 bayonet ramps machined on the external side of the receptacle connector and 3 stainless steel studs mounted inside the plug connector's coupling nut.

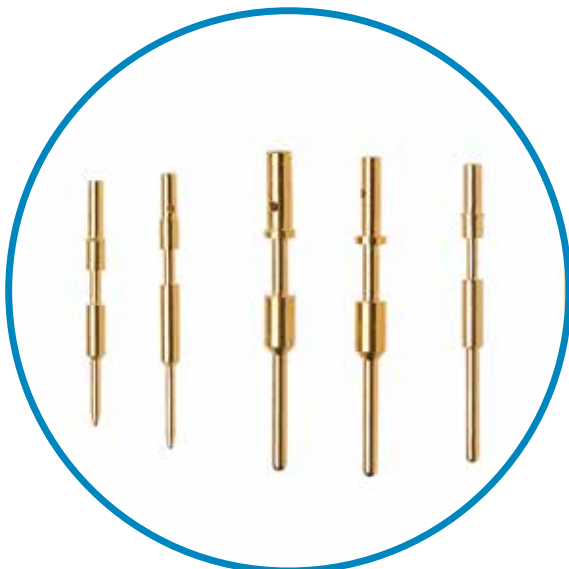

CONTACTS

Available in solder or crimp contacts, terminations for wave soldering or printed circuit board, machined from copper alloys and finished with gold or silver platings.

All contacts are manufactured in order to guarantee optimum connection properties and to provide resistance to vibration and continuous mating and unmating cycles.

Contacts for particular applications, alternative termination types and with special finishes are available to suit specific requirements.



CVS - General Characteristics

THREADED CIRCULAR CONNECTORS

This series is according to Mil-DTL-5015 specification, which concerns the electrical connectors usually called "MS". These connectors were designed for aviation applications and they have been used for many industrial applications thanks to their versatility, reliability and ease of supply.



MAIN Characteristics:

- Used in industrial applications thanks to their versatility
- 12 different shell sizes with a wide range of back shells and strain relief options for any cable requirement
- Insulating inserts and grommets are manufactured with synthetic, highly insulated, rubber compounds
- Contacts available in crimp, solder and PCB terminal



CVB - General Characteristics

BAYONET CIRCULAR CONNECTORS

This is the basic series. The front seal has a double function: it is used to supply the elastic return during the coupling and to guarantee waterproof protection. The locking is obtained by a ramp end drop of 0.15 mm. The series is compatible with all connectors in accordance with VG95234 specification.

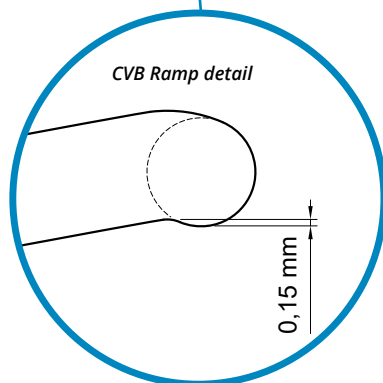

Main characteristics:

- Coupling-nut rotation of 120° only to mate connectors
- Audible, visible and tactile mating
- Interfacial seal between the two halves of the connector
- The bayonet ramps are resistant to damage

Advantages against the threaded version:

- Fast coupling and uncoupling
- The security of coupling is guaranteed and therefore its reliability is improved
- Resistance to loosening of the coupling nut also in vibration or impact condition
- IP67 waterproof protection when connectors are mated
- High number of mating cycles



CVBS - General Characteristics



BAYONET CONNECTORS PROTECTED BY A STAINLESS STEEL STUD

This series, deriving from Mil-DTL-5015 and VG95234 specs, has become a popular standard among railway connection applications. Its success is mainly due to the bayonet coupling system composed of three ramps machined on the external side of the receptacle connector and 3 stainless steel studs mounted inside the plug connector's coupling nut. The coupling point at the end of the ramp is protected by a stainless steel roller able to increase the number of mating cycles.

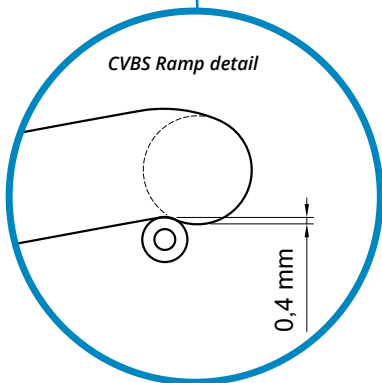

Main characteristics:

- Fast and reliable coupling (coupling-nut rotation of 120° only and mating is audible, visible and tactile)
- Vibration and impact resistance
- Manufactured in several shell versions as panel connectors (with front or rear mounting) or plug connectors (with straight backshell or 90°) and a wide range of insulators (with combination of different size contacts) from 1 to 201 poles
- Accessories for all types of cables and shielding protection hoses are also available
- Crimp contacts are suitable for wires of all sections

Advantages:

- Faster coupling, continuous and reliable service in the harshest use conditions
- Wave washer installed under the plug connector coupling nut
- IP68 waterproof protection (when connectors are mated and harnessed by using the correct accessories)





CVBSG - General Characteristics

BAYONET CONNECTORS WITH RUBBER COVERED PLUG SHELL

CVBSG series has been modified to design safety connectors. The shells of plug connectors have been rubber jacketed. Accessories in rubber material or with rubber protection are also available for cable retention.



Main characteristics:

- These connectors are particularly suitable for applications with mechanical shock
- Rubber jacket and insulating parts are in accordance with EN 45545-2 standards
- Standard panel receptacle supplied with countersunk holes for easy mating with rubber jacketed nuts
- Accessories made of rubber material or with rubber protection are also available for cable retention



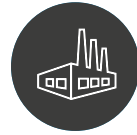

CVBR - General Characteristics

BAYONET CONNECTORS PROTECTED BY A STAINLESS ROLLER STUD

Designed to build a product even more suitable for the harshest application.
The studs of the plug connector coupling and a higher number of operations due to a lower wear of the coupling ramps.
CVBR series can be supplied from size 18 to size 40.



GG version: with rubber covered coupling nut

Roller Stud

Main characteristics:

- Suitable for higher number of operations
- The roller-stud guarantees an easier coupling due to a lower wear of the coupling ramps





GVJ - General Characteristics

OVERSIZE SHELL BAYONET CONNECTOR

This series benefits of the bayonet coupling itself suitable for the harsh conditions typical in railway applications and of more robust and reliable features obtained by the following modifications.



Main characteristics:

- Bigger shell thicknesses to guarantee resistance against impact and harsh environment.
- Rubber-jacketed coupling nut also in the standard series. The roller studs make the coupling easier and allow a bigger number of operations due to a lower wear of the coupling ramps.
- Five key polarization system (a big key and four smaller).
- Increased dimensions to install insulators with bigger number of contacts (on equal service rating) or bigger contact sizes (for higher voltage).
- Wide range of rear accessories and adapters for all types of cables and protections available.



Circular Connectors

International Standard Document Compliance

- MIL-DTL-5015: Connectors, Electrical, Circular threaded, an type, general specification for
- SAE AS 39029: Contacts, Electrical Connectors, general specification for
- VG 95234: Electrical connectors with bayonet coupling pressure-water tight, up to 245A
- EN 50124-1: Railway applications - Insulation coordination
- IEC 60077-1: Railway applications - Electric equipment for rolling stock
- EN 45545-2: Railway applications - Fire protection on railway vehicles
- NFPA 130 (ASTM E 162, ASTM E 662): Standard for Fixed Guideway Transit and Passenger Rail Systems
- UNI CEI 11170-3 : Guidelines for railway vehicle protection for tramways and with guided rail
- NFF 16-102: Railway Rolling Stock - Fire Behavior
- EN 50467: Railway applications - Rolling stock - Electrical connectors, requirements and test methods
- IEC 61373: Railway applications. Rolling stock equipment. Shock and vibration tests
- IEC 60529: Degrees of protection provided by enclosures (IP Code)
- European Directive 2011/65: RoHS complying

Features and Benefits

Robust Connection

- Fully protected connectors: no risk to damage the contacts thanks the robust shell
- Supplied with grounding finger, conductive plating and the proper rear accessory
- Suitable for polarizations to prevent un-correct coupling

Easy installation

- Fast and reliable coupling
- Backshell and accessories for fastening cable/conduit fixation

Suitable for harsh environments (adapted for outdoor use)

- Waterproof connection
- Dust proof
- Corrosion resistant

High level of performance

- Working temperature $-55^{\circ}\text{C} \div 200^{\circ}\text{C}$ (according to the inserts material)
- EMI protection with grounding finger
- Power connection up to 350A

APPLICATIONS

- Railway
- Energy
- Naval
- Industrial

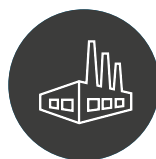

General Characteristics - Shells - Shielding characteristics

Plug connectors with grounding finger (type 96 - 98 - 96GG - 98GG - 965) when mated with receptacle connectors (type 02 - 020 - 00 - 01 - 030 - 038 - 070 - 078) and provided with rear accessories for shielded cables have shielding characteristics according to VG95234 specs.

F16 or F4 Shell Finishes are recommended for electrical conductivity from receptacle to plug.

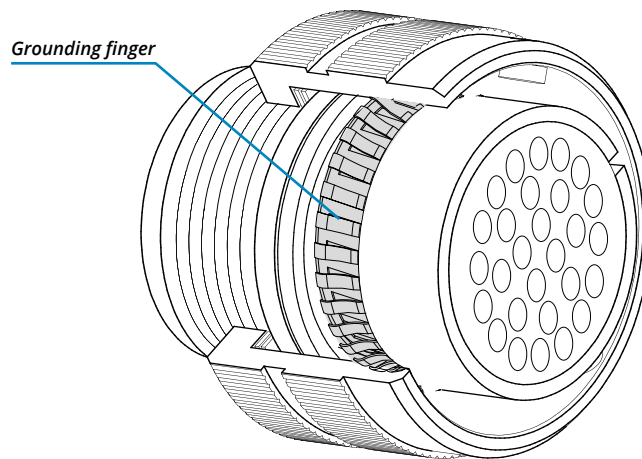

VG95234 specs: Shielding effectiveness data over frequency range (with conductive shells)

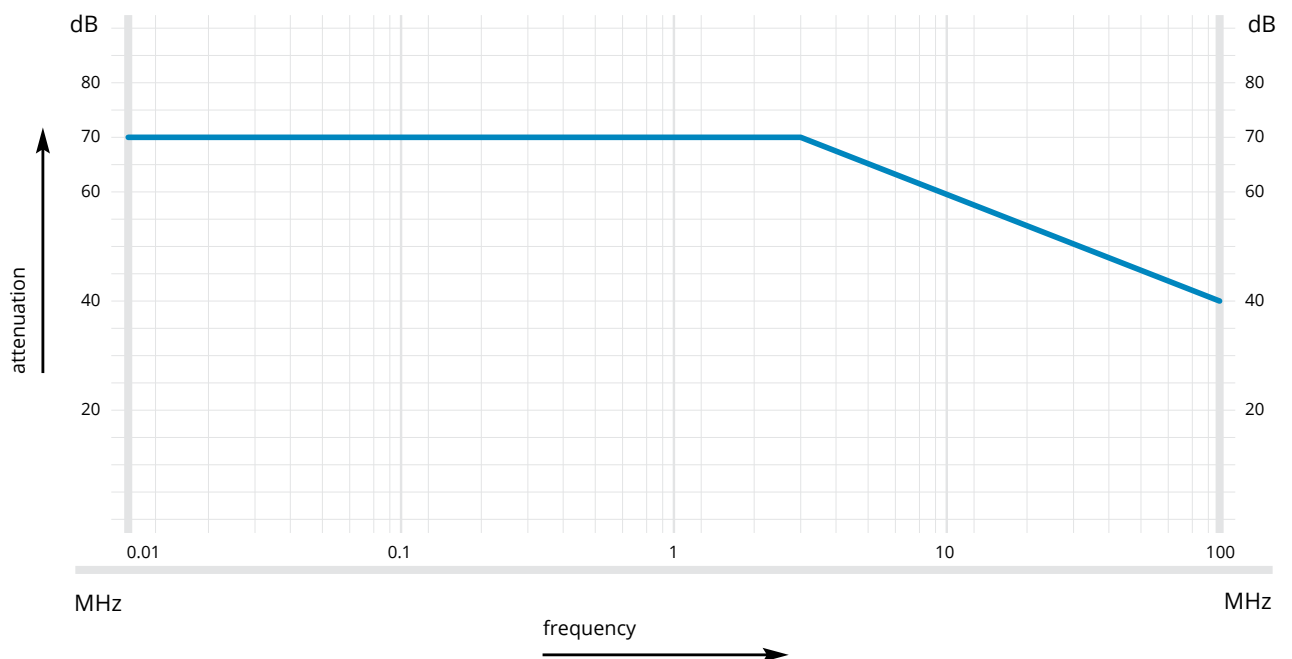

General Characteristics - Shells - Material and Finish



Shells

They are manufactured in aluminum alloy or stainless steel and can be protected against corrosion by the following finishes (Halogen-free):

- **F4** : CCF-Green passivation (conductive)
- **F5** : Electroless Nickel (conductive) - RoHS (*)
- **F7** : Black epoxy varnish (not conductive) - RoHS (*)
- **F12** : Black Hard Deep Anodization (not conductive) - RoHS (*)
- **F16** : CCF-Black passivation (conductive) - RoHS (*)
- **F26** : Black Hard Anodization - RoHS (*)
- **F30** : Colorless passivation for stainless steel (for AISI 303 or AISI 304 - without passivation AISI 316L) - RoHS (*)

(*) Restriction of Hazardous Substances Directives of the European Parliament n°2002/95/EC issued on 27 January 2003
Alternative materials and finishes are available to suit specific requirements.

Surface Treatment Code	F4	F5	F7	F12	F16	F26	F30
Shell-material	Aluminium alloy						Stainless Steel
Surface finish	CCF cadmium free	electroless nickel	epoxy-polyurethan	Hard Deep Anodizing	CCF cadmium free	Anodizing	Colorless
Type of surface	passivated	-	varnished	passivated	passivated	passivated	passivated
Surface colour	green	grey	black	black	black	black	-
Rohs conformity	no	yes	yes	yes	yes	yes	yes
Corrosion resistance	500 h ***	48 h	500 h	2000 h	500 h ***	1000 h	>2000 h
Operat. Temperature	-55°C ÷ + 125°C	-55°C ÷ + 200°C*	-55°C ÷ + 200°C*	-55°C ÷ + 125°C	-55°C ÷ + 125°C	-55°C ÷ + 125°C	-55°C ÷ + 200°C*
Electrical conductivity	good	good	non-conductive	non-conductive	good	non-conductive	good

* For use from 125°C to 200°C, consult our Commercial Office

*** 200 h in case of use with components, panel and screws, in stainless steel (galvanic corrosion)

Coupling mechanism	Threaded Connector (CVS serie)
	Reverse Bayonet Connector (CVB/CVBS/CVBSG/CVBR/GVJ Series)
Mating endurance (IEC 61300-2-2)	500 mating cycles minimum (for use up to 2000 mating cycles, consult our commercial office)
Shock and vibrations tests (EN 61373)	Category 1 body mounted (CVB/CVBS/CVBSG/CVBR/GVJ Series)
	Category 2 bogie mounted (CVBS/CVBSG/CVBR/GVJ Series)
IP protection degree (EN 60529)	IP54, IP67, CVB/CVBS: IP68 (waterproof to 10 meters - 12 hours) when used with adequate backshell or accessories

General Characteristics - Inserts



Insulating inserts and grommets

They are manufactured with the following synthetic, highly insulated, rubber compounds:

- **-** : Chloroprene rubber - for non heavy applications. Good resistance to ageing, oils and gasoline.
Rated temperature: -55° to 125°C.
- **V** : Fluoride rubber - for high temperature applications. Excellent resistance to ageing, atmospheric agents, hydraulic fluids and oils. Rated temperature: -25° to 205°C.
- **S** : Silicone rubber - for high and low temperature applications. Excellent resistance to ageing, nuclear radiations and ozone.
Rated temperature: -55° to 200°C.
- **RF** : Fire resistant rubber - halogen free - employed when no flame propagation, low opacity and non smoke toxicity is requested. Rated temperature: -35° to 180°C.
- **GVJ** : Thermoplastic resin UL94V0, flame retardant according to EN 45545-2.

Material-Code (Halogen-free)	- (standard)	V	S	RF/GVJ	GVJ
Material	chloroprene	fluoride	silicone	fire resistant	thermoplastic
Operat. Temperature	-55 ÷ +125°C	-25 ÷ +200°C	-55 ÷ +200°C	-55 ÷ +150°C	-25 ÷ +125°C
Fire protection class UL94	V0	V0	V0	V0	V0
Fire protection class EN45545-2	-	-	-	HL3 / R22 - R23	HL3 / R22 - R23

General Characteristics - Rated Current and Rated Voltage



The values mentioned below are valid for usage at 20°C ambient temperature. Let us remind you that:

- when temperatures rise, the conductivity of the contacts and therefore the value of the applicable current decreases
- at the operating current and 20°C ambient temperature the connection temperature increases anyway
- in consequence to all of the above, the current applicable to a given temperature and a determined contact size must be carefully considered

The material of the insert must be chosen to comply with both room temperature and the one produced by the electrical connection.

If in doubt we suggest you consult our Sales Office.

Contact size	Maximum current*	Rated current***	Maximum voltage drop**	Test current	Max Contact Resistance
20	7.5A	7.5A	55mV	7.5A	<12.0mΩ
18	10A	7.5A	55mV	7.5A	<12.0mΩ
16 - 16S	22A	13A	49mV	13A	<6.0mΩ
12	41A	23A	42mV	23A	<3.0mΩ
8****	73A	46A	26mV	46A	<1.0mΩ
4	135A	80A	23mV	80A	<0.5mΩ
0****	245A	150A	21mV	150A	<0.3mΩ
4/0****	350A	225A	21mV	225A	<0.2mΩ

Rated current with one contact loaded in a contact arrangement.

* Valid for ambient temperature at 20°C.

** Test according to SAE AS39029 with silver plated wire.

*** Valid for ambient temperature at 80°C.

**** Available contacts with louver.

INSULATING CHARACTERISTICS AND RATED VOLTAGE

The values of the following table:

- are valid for usage at sea level.
- refer to a clean environment of application. The pollution due to metallic or other impurities has to be taken into consideration.
- concern contacts with standard termination, solder or crimping, with size suitable for AWG section wires matching the relevant contact size. It is therefore necessary to pay attention when using contacts with crimp termination bigger than the nominal AWG size.
- Minimum Insulating Resistance $\geq 5G\Omega$.

Service code	Operating Voltage Vdc	MIL-DTL-5015	MIL-DTL-5015
		Operating Voltage Vac RMS*	Test Voltage Vac RMS*
I (instruments)	250	200	1000
A	700	500	2000
D	1250	900	2800
E	1750	1250	3500
B	2450	1750	4500
C	4200	3000	7000

* The connectors do not show any sign of breakdown when the voltage indicated in the table is applied for one minute between the two closest contacts and between the shell and the contact closest to the shell.

Caution : When nominal operating voltage exceeds 50V towards earth, the appropriate safety measures have to be adopted as described by CEI 23, IEC 309-1, BS 2618, VDE 0100 specs. The data shown on the above table are applicable only when the above mentioned safety rules are fulfilled.

General Characteristics - Contacts - electrical characteristics

RATED CURRENT

Recommended current according to the temperature.

Rated current with one contact loaded in a contact arrangement.

Electrical design and production parameters of threaded or bayonet coupling connectors are derived from Mil-DTL-5015 and VG 95234 standards. All circular connectors are produced and tested in accordance of VG 95234 standards.

RATED CURRENT CONTACTS WITH LOUVER**

Also available special contacts for high current.

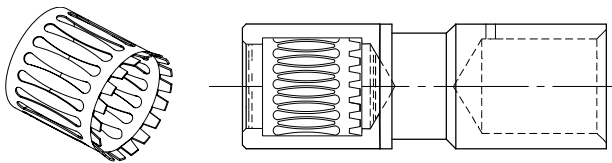

Contact Size	Maximum current	Rated Current
8L	90A	56A
0L	300A	200A
4/0L	450A	300A

** Not included in Mil or Sae Specs

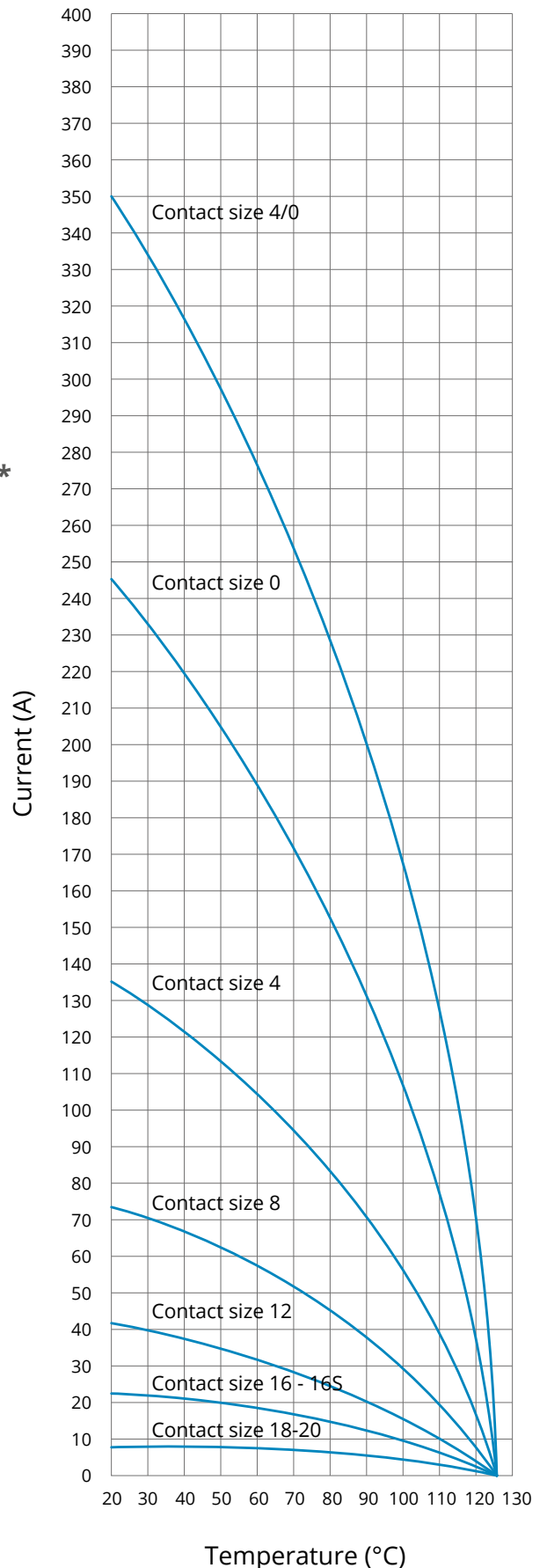
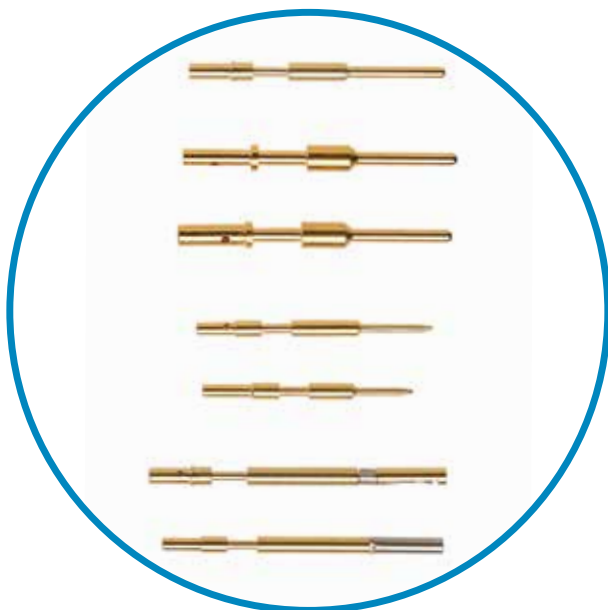

General Characteristics

Contacts They are machined in high conductivity copper alloy in order to guarantee optimum connection properties and to provide resistance to vibration and continuous mating and unmating cycles.

They are protected by a silver (standard production) or gold finish with varying plating thickness on request.

As for connector codes to be supplied with specific finish contacts please consult the section referring to the P/N explanations.

Contacts for particular applications, alternative termination types and with special finishes are available to suit specific requirements.

Engagement and disengagement force between contacts

Contact size	Engagement * in N. Max	Disengagement * in N. Max
20	1.8	0.19
18	2.4	0.19
16 - 16S	5	0.56
12	7.5	0.83
8	15	1.39
4	20	2.78
0	42.5	4.17
4/0 **	42.5	4.17

** Not included in Mil or Sae Specs

* Test according to SAE AS39029

Contacts - Part number explanation



These are available in solder or crimp version. Solder contacts are normally supplied already installed in the connector. Crimp contacts instead are supplied loose in a bag inside the connector packing or separately. Crimp contacts machined from copper alloys and finished with gold or silver platings. Special power contacts, for signal or shielding are also available. Crimp contacts are commonly used in railways applications.

They can be supplied loose in a bag inside the connector packing or separately.

Contacts material is copper alloy and they are protected by a silver (standard production) or gold finish with varying plating thickness on request.

All contacts are machined in order to guarantee optimum connection properties and to provide resistance to vibration and continuous mating and unmating cycles.

Contacts for particular applications, alternative termination types and with special finishes are available to suit specific requirements.

S	Contact Gender	S	Socket contacts
		P	Pin contacts
CR	Contact Termination	-	Solder contacts
		CR	Crimp contacts
		DS	PCB contacts
		LC	Less contacts (To be purchased separately)
CD5	Contact Plating	-	Silver plating
		CD5	Gold plating
N	Modification Code	N	Non standard Contacts and hole plugs (Consult our sales office)

Standard Crimp Contacts (specify CR in the Part Number)

Contact Size	Wire section (mm ²)	AWG cable size
20	0.15±0.3	26÷22
18	0.15±0.6	26÷20
16 - 16S	1±1.5	18÷16
12	3	12
8	-	8
4	22	4
0	53	0
4/0	107±120	4/0

Insulating Inserts And Grommets - Part number explanation



VanSystem is able to offer connectors with insulators suitable for low or high voltage with lay-out from 1 to 201 contacts.

Insulating inserts and grommets are manufactured with synthetic, highly insulated, rubber compounds.

RF	Insulating material	-	Chloroprene rubber	For non heavy applications. Good resistance to ageing, oils and gasoline. Rated temperature: -55° to +125°C*
		V	Fluoride rubber	Excellent resistance to ageing, atmospheric agents, hydraulic fluids and oils. Rated temperature: -25° to +200°C*
		S	Silicone rubber	For high and low temperature applications. Excellent resistance to ageing, nuclear radiations and ozone. Rated temperature: -55° to +200°C*
		RF	Fire resistant rubber	Halogen free Employed when no flame propagation, low opacity and non smoke toxicity are requested. Qualified according to: • EN 45545-2 HL3 R22/R23 • NFPA 130 Rated temperature: -55° to +150°C*
20-27	Size and Insert Arrangement	xx-xx	Size - Arrangement	Inserts and grommets arrangements List by shell size List by contacts total quantity
X	Polarization Code	-	No rotation	
		W,X,Y,Z,Q	Rotation	Alternate insert position

* Temperature range can be changed according to shell finishes.

Insulating Inserts and Grommets - List by contacts total quantity

CVS-CVB-CVBS-CVBSG-CVBR - Inserts Arrangement

1 CONTACT

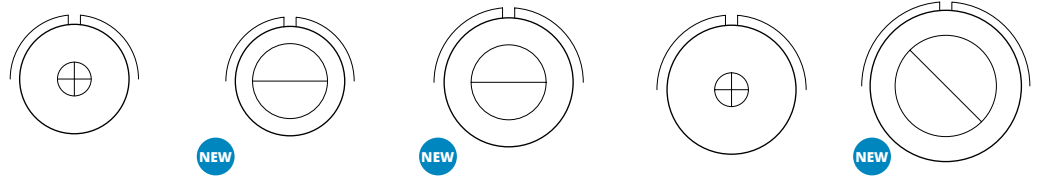

Insert Arrangement	16-2**	16-12	18-6	18-16**	20-2
N° of Contacts	1	1	1	1	1
Contact Size/ Current rating	12 (23A)	4 (80A)	4 (80A)	12 (23A)	0 (150A)
Service Rating	E 1750 Vdc 1250 Vac	A 700 Vdc 500 Vac	D 1250 Vdc 900 Vac	C 4200 Vdc 3000 Vac	D 1250 Vdc 900 Vac
Grommet	-	-	-	-	-

1 CONTACT

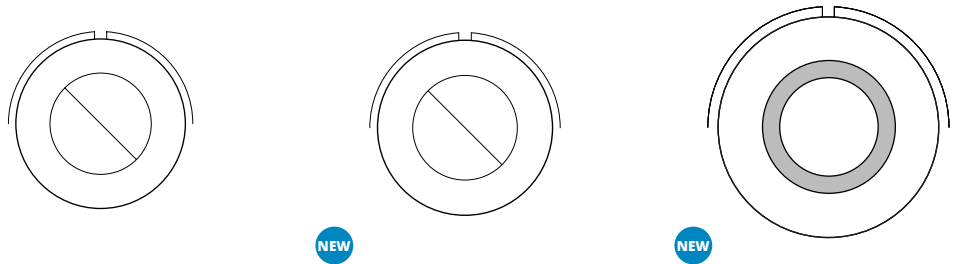

Insert Arrangement	22-7**	22A1 (L)	28A1 (L)
N° of Contacts	1	1	1
Contact Size/ Current rating	0 (150A)	0 (150A)	4/0 (225A)
Service Rating	E 1750 Vdc 1250 Vac	750V (according to APTA SS-E-001-98)	750V OV4 PD4
Grommet	-	●	-

2 CONTACTS

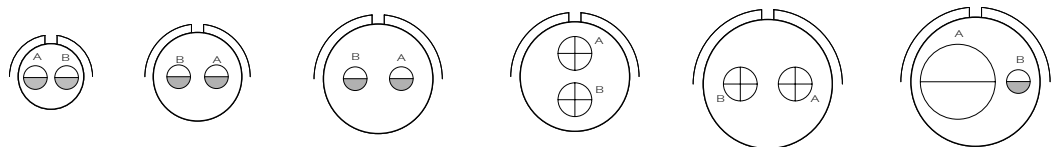

Insert Arrangement	10SL-4	14S-9	16S-4	16-11**	18-3	18-14**
N° of Contacts	2	2	2	2	2	2
Contact Size/ Current rating	16S (13A)	16S (13A)	16S (13A)	12 (23A)	12 (23A)	n° 1-4 (80A) n° 1-16 (13A)
Service Rating	A 700 Vdc 500 Vac	A 700 Vdc 500 Vac	D 1250 Vdc 900 Vac	A 700 Vdc 500 Vac	D 1250 Vdc 900 Vac	A 700 Vdc 500 Vac
Grommet	●	●	●	-	-	-

● Grommet Available

** On request (please consult our Sales Office)

(L) Long Insert

(S) Short Insert

(NS) Non Standard Shell Type

Front view Pin contacts insert



ST Contacts size legend

20 18 16 12 8 4 0 4/0

Insulating Inserts and Grommets - List by contacts total quantity

CVS-CVB-CVBS-CVBSG-CVBR - Inserts Arrangement

2 CONTACTS

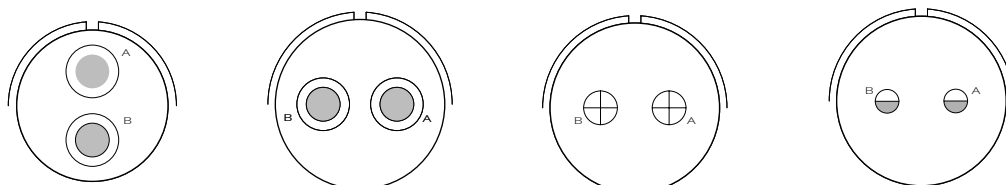

Insert Arrangement	20-23**	22-1	22-8**	22-11**
N° of Contacts	2	2	2	2
Contact Size/ Current rating	8 (46A)	8 (46A)	12 (23A)	16 (13A)
Service Rating	A 700 Vdc 500 Vac	D 1250 Vdc 900 Vac	E 1750 Vdc 1250 Vac	B 2450 Vdc 1750 Vac
Grommet	-	●	-	-

2 CONTACTS

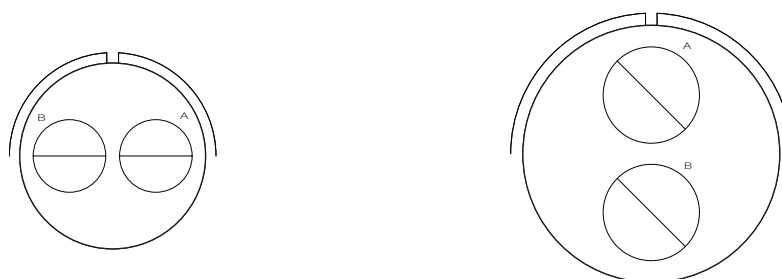

Insert Arrangement	24-9	32-5
N° of Contacts	2	2
Contact Size/ Current rating	4 (80A)	0 (150A)
Service Rating	A 700 Vdc 500 Vac	D 1250 Vdc 900 Vac
Grommet	●	●

3 CONTACTS

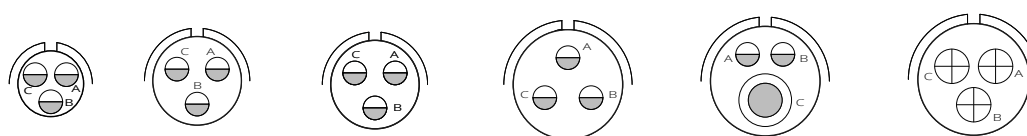

Insert Arrangement	10SL-3	14S-1***	14S-7	16S-5	16-7**	16-10
N° of Contacts	3	3	3	3	3	3
Contact Size/ Current rating	16S (13A)	16S (13A)	16S (13A)	16S (13A)	n° 1-8 (46A) n° 2-16 (13A)	12 (23A)
Service Rating	A 700 Vdc 500 Vac	A 700 Vdc 500 Vac	A 700 Vdc 500 Vac	A 700 Vdc 500 Vac	A 700 Vdc 500 Vac	A 700 Vdc 500 Vac
Grommet	●	-	●	●	-	●

*** Same as 14S-7S (it is different from MIL-STD-1651 specs)

● Grommet Available

** On request (please consult our Sales Office)

(L) Long Insert

(S) Short Insert

(NS) Non Standard Shell Type

Front view Pin contacts insert

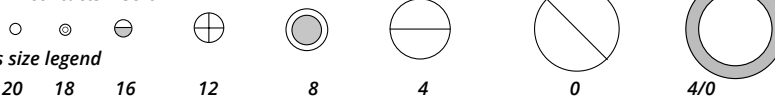

Insulating Inserts and Grommets - List by contacts total quantity

CVS-CVB-CVBS-CVBSG-CVBR - Inserts Arrangement

3 CONTACTS

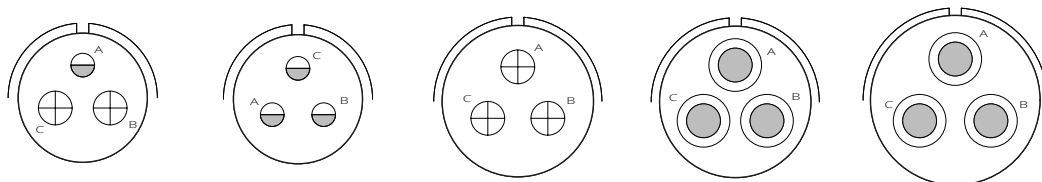

Insert Arrangement	18-5	18-22	20-3	20-19	22-2 (NS)
N° of Contacts	3	3	3	3	3
Contact Size/ Current rating	n° 2-12 (23A) n° 1-16 (13A)	16 (13A)	12 (23A)	8 (46A)	8 (46A)
Service Rating	D 1250 Vdc 900 Vac	D 1250 Vdc 900 Vac	D 1250 Vdc 900 Vac	A 700 Vdc 500 Vac	D 1250 Vdc 900 Vac
Grommet	-	●	●	●	●

3 CONTACTS

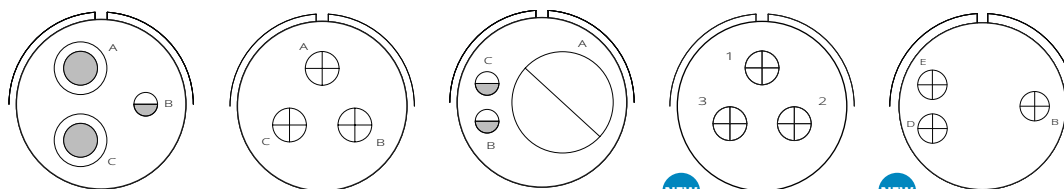

Insert Arrangement	22-6**	22-9**	22-21	22A3 (L)	24-12/1
N° of Contacts	3	3	3	3	3
Contact Size/ Current rating	n° 2-8 (46A) n° 1-16 (13A)	12 (23A)	n° 1-0 (150A) n° 2-16 (13A)	12 (23A)	8 (46A)
Service Rating	D 1250 Vdc 900 Vac	E 1750 Vdc 1250 Vac	A 700 Vdc 500 Vac	B 2450 Vdc 1750 Vac	A 700 Vdc 500 Vac
Grommet	-	●	●	●	●

3 CONTACTS

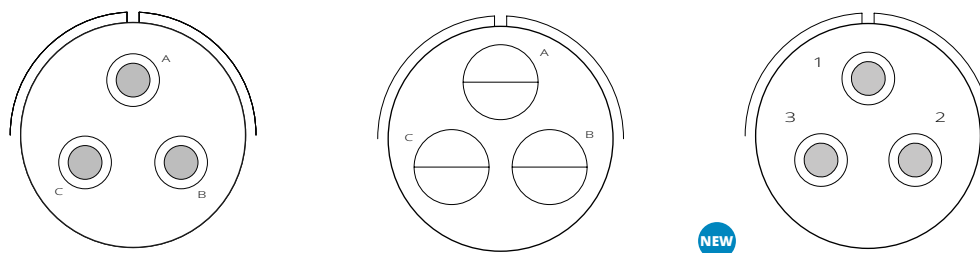

Insert Arrangement	28-3	28-6	28A3 (L)
N° of Contacts	3	3	3
Contact Size/ Current rating	8 (46A)	4 (80A)	8 (46A)
Service Rating	E 1750 Vdc 1250 Vac	D 1250 Vdc 900 Vac	B 2450 Vdc 1750 Vac
Grommet	●	●	●

● Grommet Available

** On request (please consult our Sales Office)

(L) Long Insert

(S) Short Insert

(NS) Non Standard Shell Type

Front view Pin contacts insert

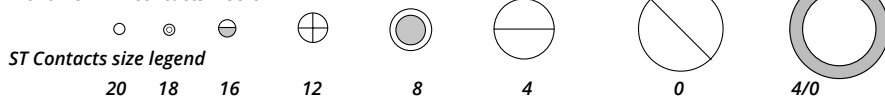

ST Contacts size legend

20 18 16 12 8 4 0 4/0

Insulating Inserts and Grommets - List by contacts total quantity

CVS-CVB-CVBS-CVBSG-CVBR - Inserts Arrangement

3 CONTACTS

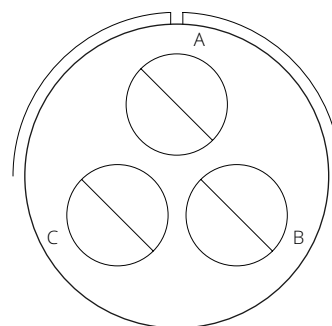
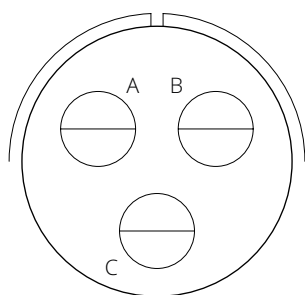

Insert Arrangement	32A3 (L)	36-4
N° of Contacts	3	3
Contact Size/ Current rating	4 (80A)	0 (150A)
Service Rating	E 1750 Vdc 1250 Vac	A=D - B/C=A
Grommet	●	●

3 CONTACTS

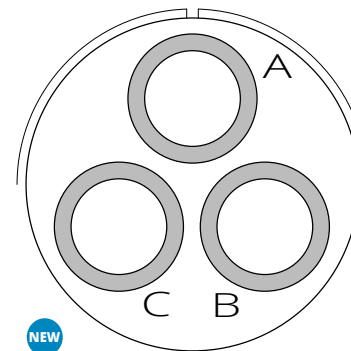
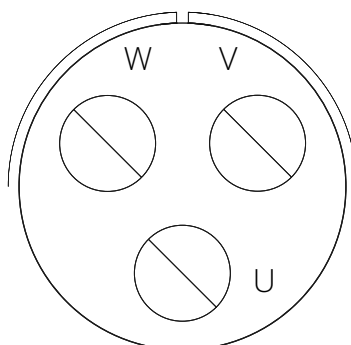
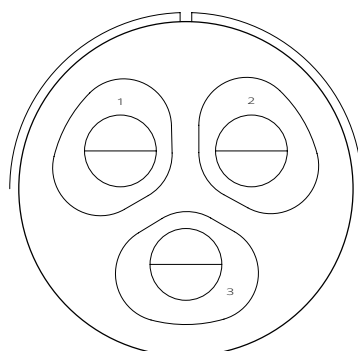

Insert Arrangement	40A3 (L)	40C3** (L)	40D3
N° of Contacts	3	3	3
Contact Size/ Current rating	4 (80A)	0 (150A)	4/0 (225A)
Service Rating	E 1750 Vdc 1250 Vac	B 2450 Vdc 1750 Vac	A 700 Vdc 500 Vac
Grommet	-	-	●

4 CONTACTS

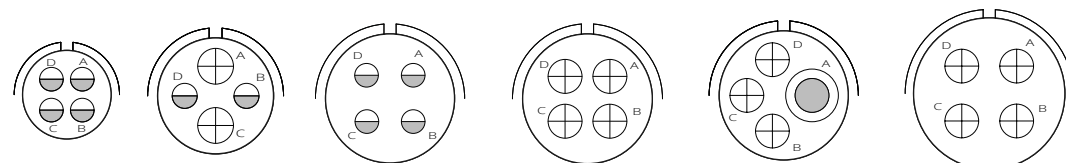

Insert Arrangement	14S-2	16-9	18-4	18-10	18-13**	20-4
N° of Contacts	4	4	4	4	4	4
Contact Size/ Current rating	16S (13A)	n° 2-12 (23A) n° 2- 16 (13A)	16 (13A)	12 (23A)	n° 1-8 (46A) n° 3-12 (23A)	12 (23A)
Service Rating	I 250 Vdc 200 Vac	A 700 Vdc 500 Vac	D 1250 Vdc 900 Vac	A 700 Vdc 500 Vac	A 700 Vdc 500 Vac	D 1250 Vdc 900 Vac
Grommet	●	-	●	●	-	●

● Grommet Available

** On request (please consult our Sales Office)

(L) Long Insert

(S) Short Insert

(NS) Non Standard Shell Type

Front view Pin contacts insert

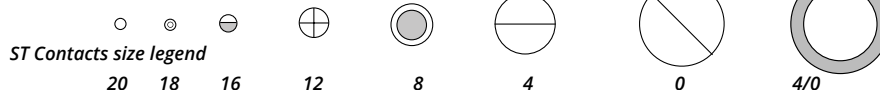

ST Contacts size legend

20 18 16 12 8 4 0 4/0

Insulating Inserts and Grommets - List by contacts total quantity

CVS-CVB-CVBS-CVBSG-CVBR - Inserts Arrangement

4 CONTACTS

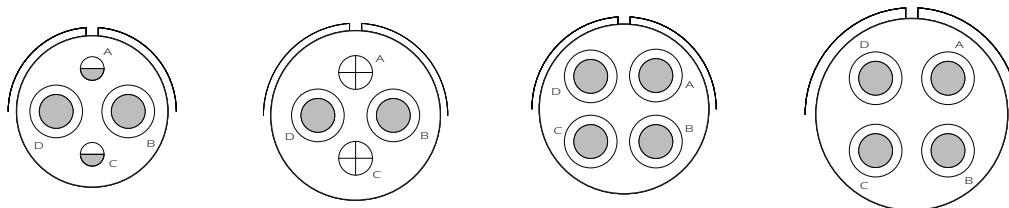

Insert Arrangement	20-24	22-4**	22-22	24-22
N° of Contacts	4	4	4	4
Contact Size/ Current rating	n° 2-8 (46A) n° 2-16 (13A)	n° 2-8 (46A) n° 2-12 (23A)	4-8 (46A)	4-8 (46A)
Service Rating	A 700 Vdc 500 Vac	A 700 Vdc 500 Vac	A 700 Vdc 500 Vac	D 1250 Vdc 900 Vac
Grommet	-	-	●	●

4 CONTACTS

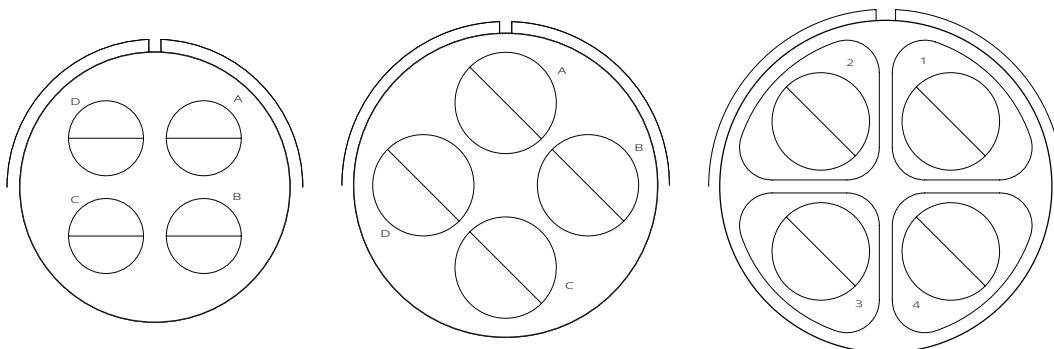

Insert Arrangement	32-17	36-5	40A4 (L)
N° of Contacts	4	4	4
Contact Size/ Current rating	4 (80A)	0 (150A)	0 (150A)
Service Rating	D 1250 Vdc 900 Vac	A 700 Vdc 500 Vac	E 1750 Vdc 1250 Vac
Grommet	-	-	-

5 CONTACTS

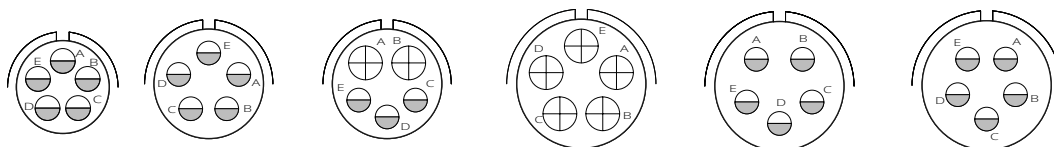

Insert Arrangement	14S-5	16S-8	16A5	18-11	18-20	18A5 (L)
N° of Contacts	5	5	5	5	5	5
Contact Size/ Current rating	16S (13A)	16S (13A)	n° 2-12 (23A) n° 3- 16 (13A)	12 (23A)	16 (13A)	16 (13A)
Service Rating	I 250 Vdc 200 Vac	A 700 Vdc 500 Vac	A 700 Vdc 500 Vac	A 700 Vdc 500 Vac	A 700 Vdc 500 Vac	D 1250 Vdc 900 Vac
Grommet	●	-	-	●	●	-

- Grommet Available
- ** On request (please consult our Sales Office)
- (L) Long Insert
- (S) Short Insert
- (NS) Non Standard Shell Type

Front view Pin contacts insert

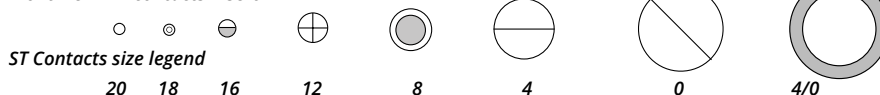

ST Contacts size legend

Insulating Inserts and Grommets - List by contacts total quantity

CVS-CVB-CVBS-CVBSG-CVBR - Inserts Arrangement

5 CONTACTS

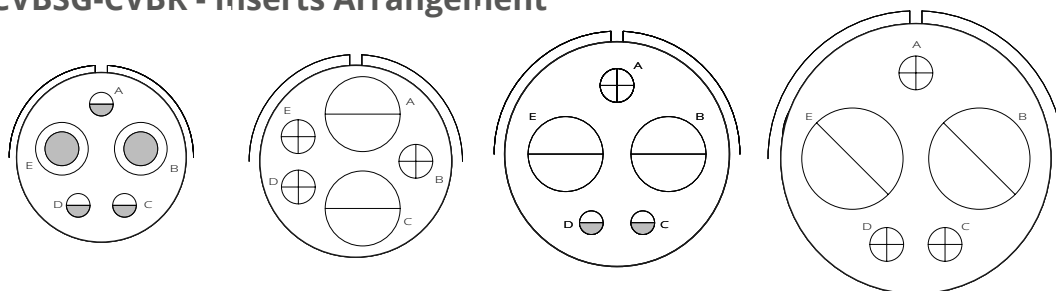

Insert Arrangement	22-12** (NS)	24-12	28-5	32-1
N° of Contacts	5	5	5	5
Contact Size/ Current rating	n° 2-8 (46A) n° 3-16 (13A)	n° 2-4 (80A) n° 3-12 (23A)	n° 2-4(80A) n° 1-12(23A) n° 2-16(13A)	n° 2-0 (150A) n° 3-12 (23A)
Service Rating	D 1250 Vdc 900 Vac	A 700 Vdc 500 Vac	D 1250 Vdc 900 Vac	A=E - Bal.=D
Grommet	-	-	-	●

5 CONTACTS

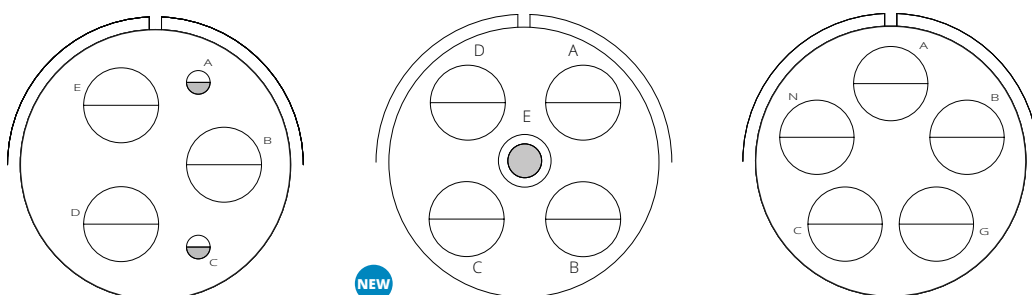

Insert Arrangement	32-2**	32-79	32A5 (L)
N° of Contacts	5	5	5
Contact Size/ Current rating	n° 3-4 (80A) n° 2-16 (13A)	n° 4-4 (80A) n° 1-8 (46A)	4 (80A)
Service Rating	E 1750 Vdc 1250 Vac	D 1250 Vdc 900 Vac	D 1250 Vdc 900 Vac
Grommet	-	●	-

5 CONTACTS

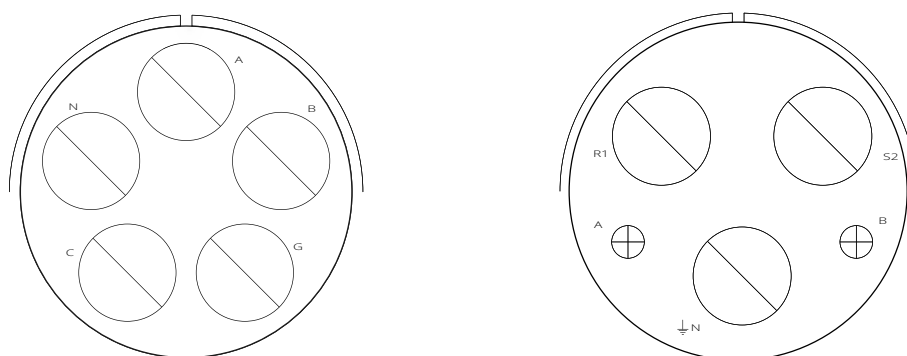

Insert Arrangement	40A5	40B3 (L)
N° of Contacts	5	5
Contact Size/ Current rating	0 (150A)	n° 3-0 (150A) n° 2-12 (23A)
Service Rating	A 700 Vdc 500 Vac	A 700 Vdc 500 Vac
Grommet	-	-

● Grommet Available

** On request (please consult our Sales Office)

(L) Long Insert

(S) Short Insert

(NS) Non Standard Shell Type

Front view Pin contacts insert

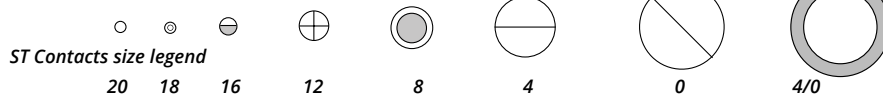

ST Contacts size legend

20 18 16 12 8 4 0 4/0

Insulating Inserts and Grommets - List by contacts total quantity

CVS-CVB-CVBS-CVBSG-CVBR - Inserts Arrangement

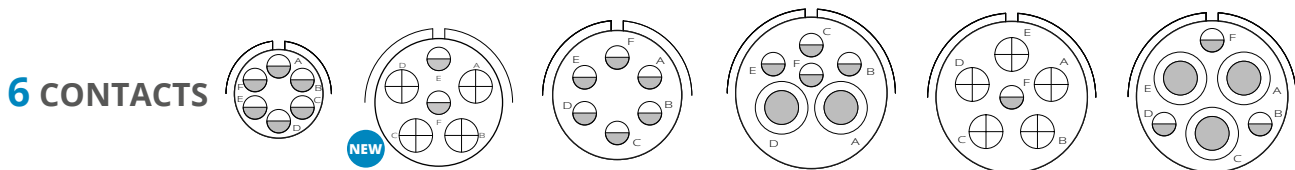

Insert Arrangement	14S-6	18-06	18-12	20-8** (NS)	20-17**	20-22**
N° of Contacts	6	6	6	6	6	6
Contact Size/ Current rating	16S (13A)	n° 4-12 (23A) n° 2-16 (13A)	16 (13A)	n° 2-8 (46A) n° 4-16 (13A)	n° 5-12 (23A) n° 1-16 (13A)	n° 3-8 (46A) n° 3-16 (13A)
Service Rating	I 250 Vdc 200 Vac	A 700 Vdc 500 Vac	A 700 Vdc 500 Vac	I 250 Vdc 200 Vac	A 700 Vdc 500 Vac	A 700 Vdc 500 Vac
Grommet	●	-	●	-	-	-

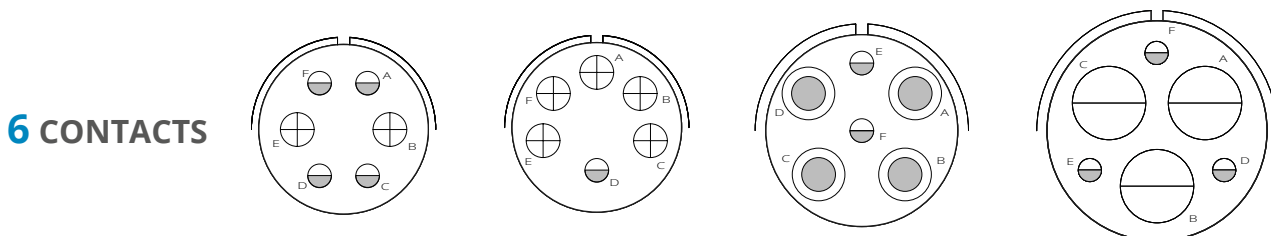

Insert Arrangement	22-5**	22-15**	24-06**	28-22
N° of Contacts	6	6	6	6
Contact Size/ Current rating	n° 2-12 (23A) n° 4-16 (13A)	n° 5-12 (23A) n° 1-16 (13A)	n° 4-8 (46A) n° 4-16 (13A)	n° 3-4 (80A) n° 3-16 (13A)
Service Rating	D 1250 Vdc 900 Vac	D=E - Bal.=A	D 1250 Vdc 900 Vac	D 1250 Vdc 900 Vac
Grommet	-	-	-	-

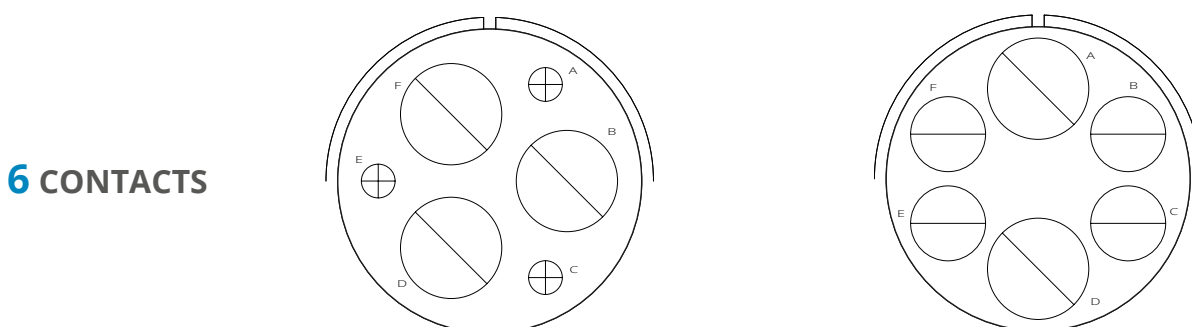

Insert Arrangement	36-3	36-6**
N° of Contacts	6	6
Contact Size/ Current rating	n° 3-0 (150A) n° 3-12 (23A)	n° 2-0 (150A) n° 4-4 (80A)
Service Rating	D 1250 Vdc 900 Vac	A 700 Vdc 500 Vac
Grommet	●	-

● Grommet Available
 ** On request (please consult our Sales Office)
 (L) Long Insert
 (S) Short Insert
 (NS) Non Standard Shell Type

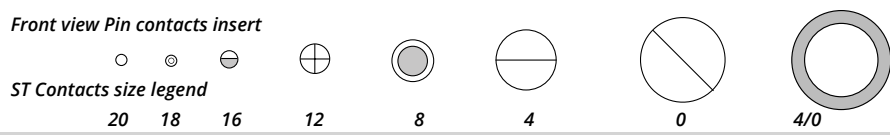

Insulating Inserts and Grommets - List by contacts total quantity

CVS-CVB-CVBS-CVBSG-CVBR - Inserts Arrangement

6 CONTACTS

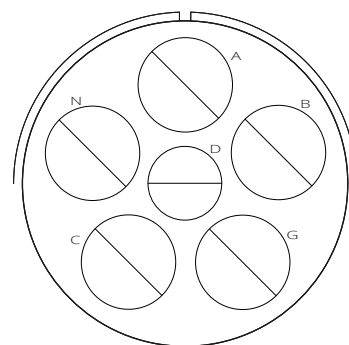
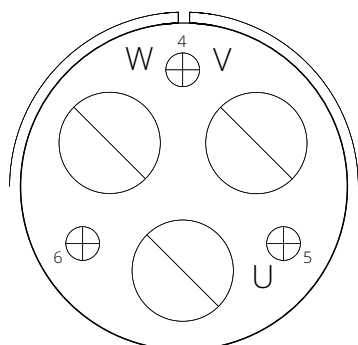

Insert Arrangement	40C6 (L)	40B6
N° of Contacts	6	6
Contact Size/ Current rating	n° 3-0 (150A) n° 3-12 (23A)	n° 5-0 (150A) n° 1-4 (80A)
Service Rating	B 2450 Vdc 1750 Vac	A 700 Vdc 500 Vac
Grommet	-	●

7 CONTACTS

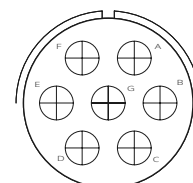
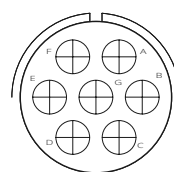
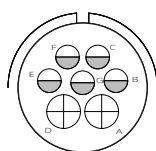
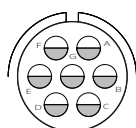
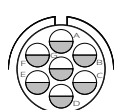

Insert Arrangement	14SA7	16S-1	18-9	20-15	22-28**
N° of Contacts	7	7	7	7	7
Contact Size/ Current rating	16S (13A)	16S (13A)	n° 2-12 (23A) n° 5-16 (13A)	12 (23A)	12 (23A)
Service Rating	I 250 Vdc 200 Vac	A 700 Vdc 500 Vac	I 250 Vdc 200 Vac	A 700 Vdc 500 Vac	A 700 Vdc 500 Vac
Grommet	●	●	-	●	-

7 CONTACTS

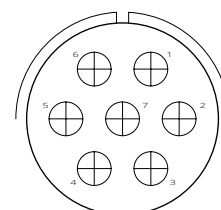
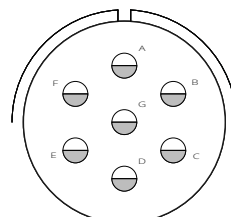
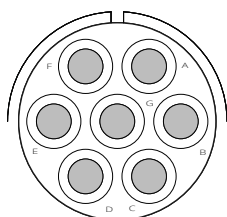
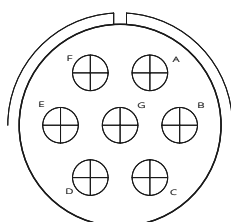

Insert Arrangement	24-2	24-10	24-27	24A7**
N° of Contacts	7	7	7	7
Contact Size/ Current rating	12 (23A)	8 (46A)	16 (13A)	12 (23A)
Service Rating	D 1250 Vdc 900 Vac	A 700 Vdc 500 Vac	E 1750 Vdc 1250 Vac	D 1250 Vdc 900 Vac
Grommet	●	●	●	-

● Grommet Available

** On request (please consult our Sales Office)

(L) Long Insert

(S) Short Insert

(NS) Non Standard Shell Type

Front view Pin contacts insert

ST Contacts size legend

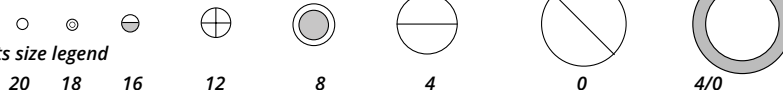

Insulating Inserts and Grommets - List by contacts total quantity

CVS-CVB-CVBS-CVBSG-CVBR - Inserts Arrangement

7 CONTACTS

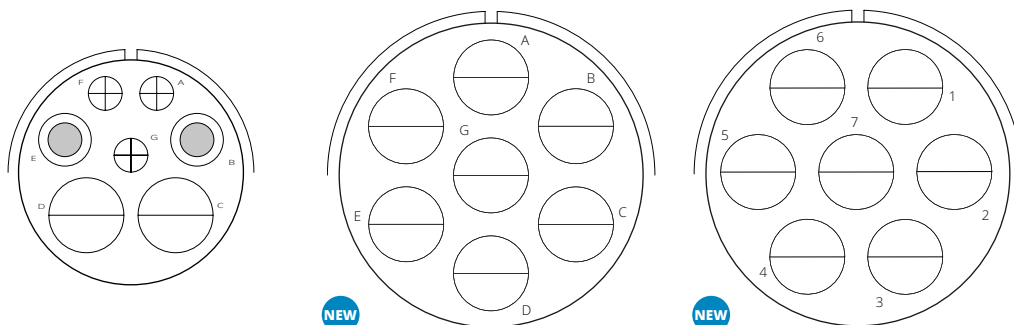

Insert Arrangement	28-10	36-77	36A7 (L)
N° of Contacts	7	7	7
Contact Size/ Current rating	n° 2-4(80A) n° 2-8(46A) n° 3-12(23A)	4 (80A)	4 (80A)
Service Rating	G=D - Bal.=A	D 1250 Vdc 900 Vac	B 2450 Vdc 1750 Vac
Grommet	-	●	●

8 CONTACTS

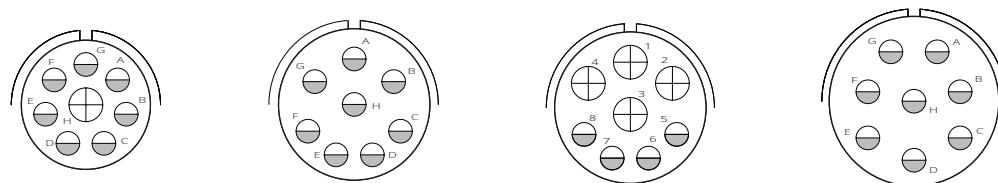

Insert Arrangement	18-8	20-7	20B8	22-18
N° of Contacts	8	8	8	8
Contact Size/ Current rating	n° 1-12(23A) n° 7-16 (13A)	16 (13A)	n° 4-12(23A) n° 4-16 (13A)	16 (13A)
Service Rating	A 700 Vdc 500 Vac	A,B,H,G=D - Bal.=A	A 700 Vdc 500 Vac	A 700 Vdc 500 Vac
Grommet	-	●	-	●

8 CONTACTS

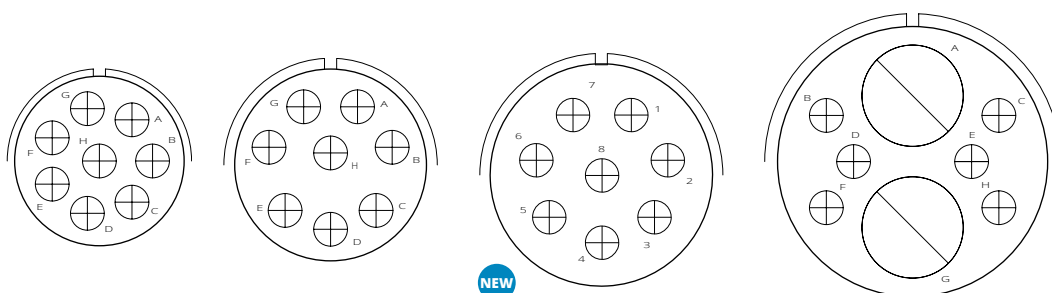

Insert Arrangement	22-23	24-6**	28B8 (L)	32-15
N° of Contacts	8	8	8	8
Contact Size/ Current rating	12(23A)	12(23A)	12(23A)	n° 2-0 (150A) n° 6-12(23A)
Service Rating	H=D - Bal.=A	A,G,H=D - Bal.=A	750V (according to APTA SS-E-001-98)	D 1250 Vdc 900 Vac
Grommet	●	-	●	-

● Grommet Available

** On request (please consult our Sales Office)

(L) Long Insert

(S) Short Insert

(NS) Non Standard Shell Type

Front view Pin contacts insert

○ ⊙ ⊖ ⊕

ST Contacts size legend

20 18 16 12 8 4 0 4/0

Insulating Inserts and Grommets - List by contacts total quantity

CVS-CVB-CVBS-CVBSG-CVBR - Inserts Arrangement

8 CONTACTS

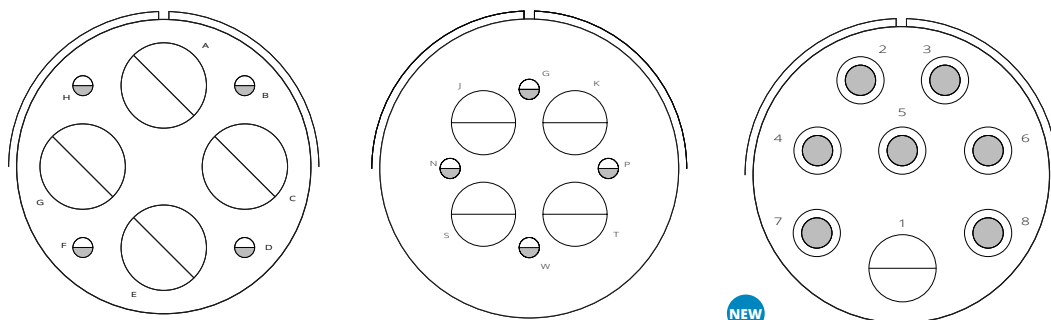

Insert Arrangement	40A8	40A10	40B7 (L)
N° of Contacts	8	8	8
Contact Size/ Current rating	n° 4-0 (150A) n° 4-16 (13A)	n° 4-4 (80A) n° 4-16 (13A)	n° 1-4 (80A) n° 7-8 (46A)
Service Rating	E 1750 Vdc 1250 Vac	D 1250 Vdc 900 Vac	750V (according to APTA SS-E-001-98)
Grommet	●	●	●

9 CONTACTS

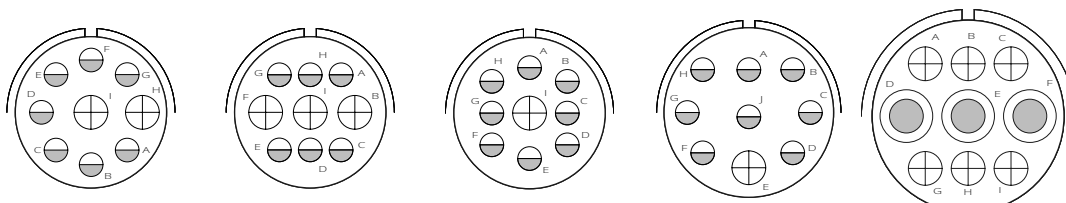

Insert Arrangement	20-16**	20-18	20-21**	22-17**	24-11
N° of Contacts	9	9	9	9	9
Contact Size/ Current rating	n° 2-12 (23A) n° 7-16 (13A)	n° 3-12 (23A) n° 6-16 (13A)	n° 1-12 (23A) n° 8-16 (13A)	n° 1-12 (23A) n° 8-16 (13A)	n° 3-8 (46A) n° 6-12 (23A)
Service Rating	A 700 Vdc 500 Vac	A 700 Vdc 500 Vac	A 700 Vdc 500 Vac	A=D - Bal.=A	A 700 Vdc 500 Vac
Grommet	-	●	-	-	●

9 CONTACTS

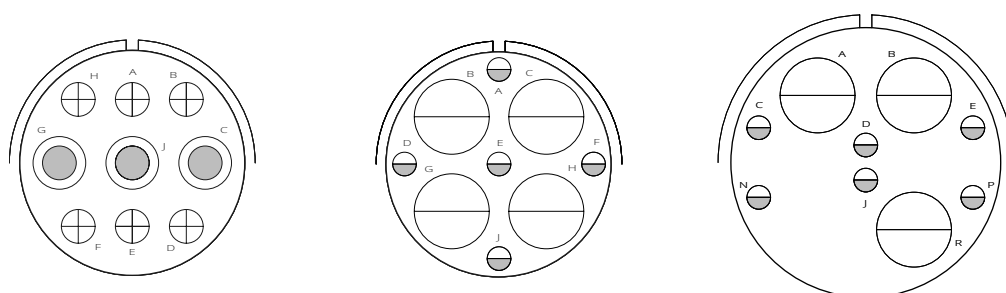

Insert Arrangement	28-1	28A9	32A9
N° of Contacts	9	9	9
Contact Size/ Current rating	n° 3-8 (46A) n° 6-12 (23A)	n° 4-4 (80A) n° 5-16 (13A)	n° 3-4 (80A) n° 6-16 (13A)
Service Rating	A,J,E=D - Bal.=A	A 700 Vdc 500 Vac	A 700 Vdc 500 Vac
Grommet	●	-	-

● Grommet Available

** On request (please consult our Sales Office)

(L) Long Insert

(S) Short Insert

(NS) Non Standard Shell Type

Front view Pin contacts insert

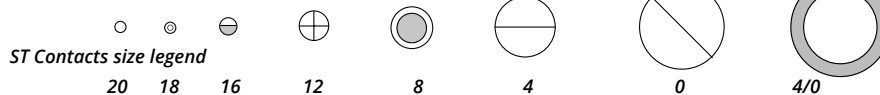

Insulating Inserts and Grommets - List by contacts total quantity

CVS-CVB-CVBS-CVBSG-CVBR - Inserts Arrangement

10 CONTACTS

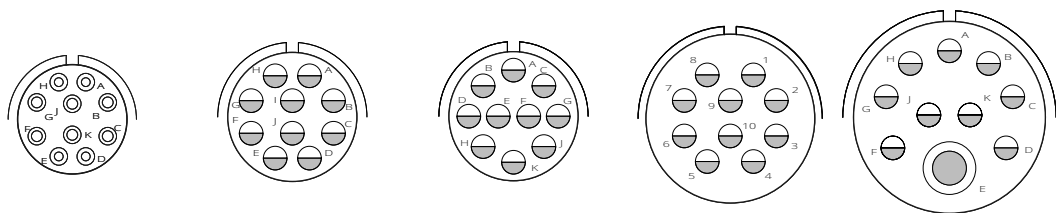

Insert Arrangement	16A10**	18-1	18-19	22A10	24-21**
N° of Contacts	10	10	10	10	10
Contact Size/ Current rating	18 (7.5A)	16 (13A)	16 (13A)	16 (13A)	n° 1-8 (46A) n° 9-16 (13A)
Service Rating	A 700 Vdc 500 Vac	B,C,F,G=A - Bal.=I	A 700 Vdc 500 Vac	A 700 Vdc 500 Vac	D 1250 Vdc 900 Vac
Grommet	-	●	●	●	-

10 CONTACTS

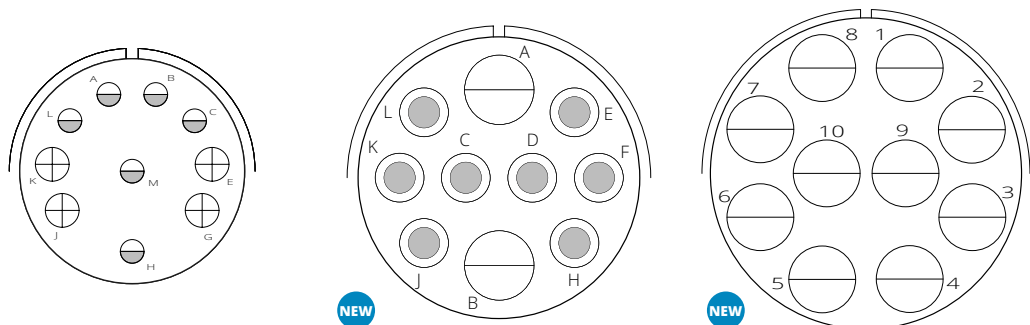

Insert Arrangement	28-19**	36A10 (L)	40B10
N° of Contacts	10	10	10
Contact Size/ Current rating	n° 4-12 (23A) n° 6-16 (13A)	n° 2-4 (80A) n° 8-8 (46A)	4 (80A)
Service Rating	H,M=B A,B=D - Bal.=A	A 700 Vdc 500 Vac	A 700 Vdc 500 Vac
Grommet	-	-	●

11 CONTACTS

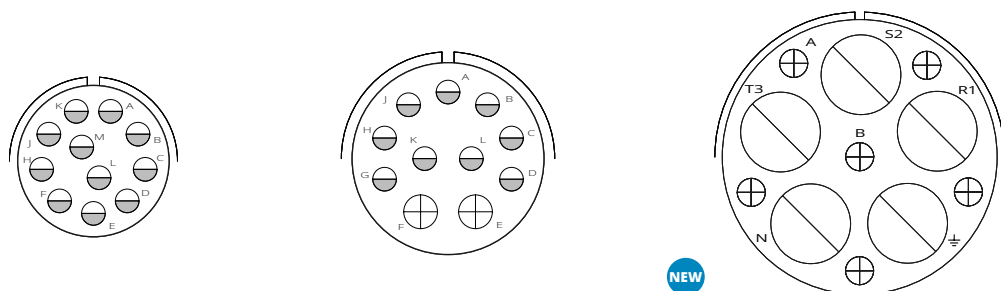

Insert Arrangement	20-33	24-20	40A11 (L)
N° of Contacts	11	11	11
Contact Size/ Current rating	16 (13A)	n° 2-12 (23A) n° 9-16 (13A)	n° 5-0 (150A) n° 6-12 (23A)
Service Rating	A 700 Vdc 500 Vac	D 1250 Vdc 900 Vac	B,N,T3,S2,R1,≠=D - Bal.=A
Grommet	●	●	-

● Grommet Available

** On request (please consult our Sales Office)

(L) Long Insert

(S) Short Insert

(NS) Non Standard Shell Type

Front view Pin contacts insert

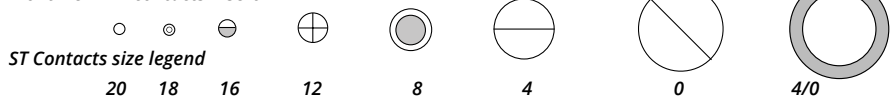

ST Contacts size legend

20 18 16 12 8 4 0 4/0

Insulating Inserts and Grommets - List by contacts total quantity

CVS-CVB-CVBS-CVBSG-CVBR - Inserts Arrangement

12 CONTACTS

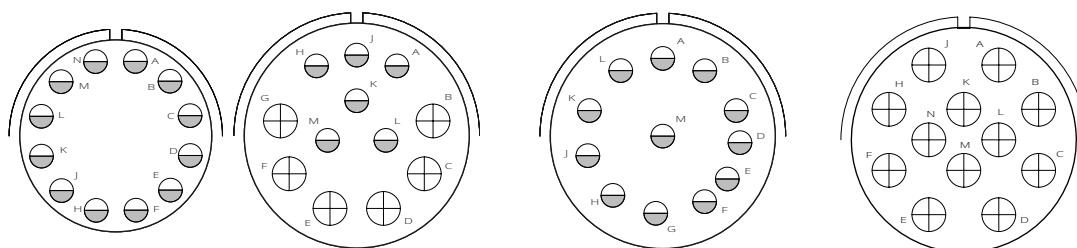

Insert Arrangement	24-19	28-9**	28-18	28-51 (L)
N° of Contacts	12	12	12	12
Contact Size/ Current rating	16 (13A)	n° 6-12 (23A) n° 6-16 (13A)	16 (13A)	12 (23A)
Service Rating	A 700 Vdc 500 Vac	D 1250 Vdc 900 Vac	M=C - A,B=A - G,H,J,K,L=D - Bal.=I	D 1250 Vdc 900 Vac
Grommet	●	-	●	●

13 CONTACTS

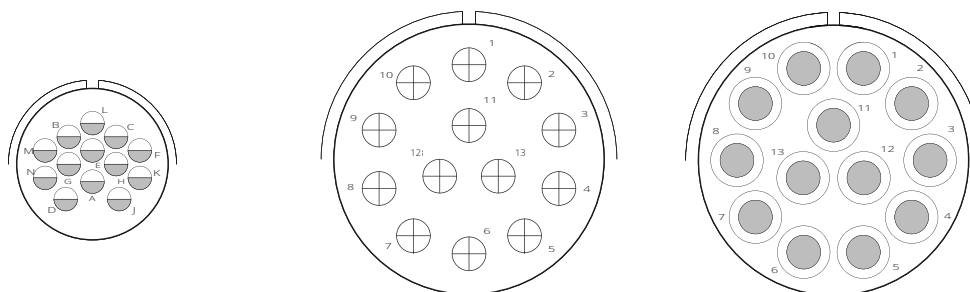

Insert Arrangement	20-11	32A13	32B13**
N° of Contacts	13	13	13
Contact Size/ Current rating	16 (13A)	12 (23A)	8 (46A)
Service Rating	I 250 Vdc 200 Vac	D 1250 Vdc 900 Vac	A 700 Vdc 500 Vac
Grommet	-	●	●

14 CONTACTS

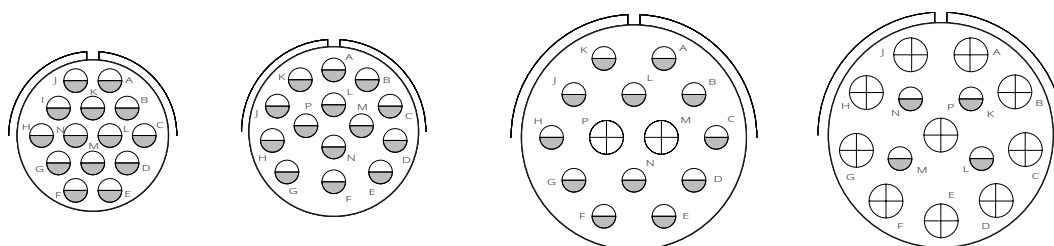

Insert Arrangement	20-27	22-19** (NS)	28-2	28-20**
N° of Contacts	14	14	14	14
Contact Size/ Current rating	16 (13A)	16 (13A)	n° 2-12 (23A) n° 12-16 (13A)	n° 10-12 (23A) n° 4-16 (13A)
Service Rating	A 700 Vdc 500 Vac	A 700 Vdc 500 Vac	D 1250 Vdc 900 Vac	A 700 Vdc 500 Vac
Grommet	●	●	-	-

● Grommet Available

** On request (please consult our Sales Office)

(L) Long Insert

(S) Short Insert

(NS) Non Standard Shell Type

Front view Pin contacts insert

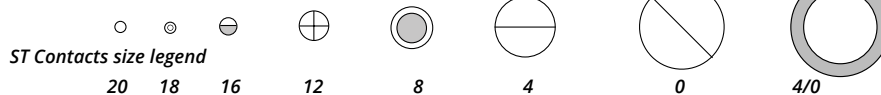

Insulating Inserts and Grommets - List by contacts total quantity

CVS-CVB-CVBS-CVBSG-CVBR - Inserts Arrangement

14 CONTACTS

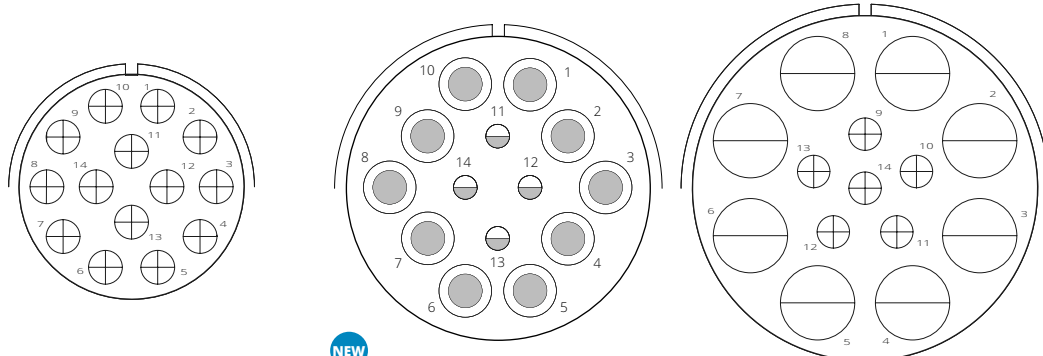

Insert Arrangement	28A14	36D78	40A14
N° of Contacts	14	14	14
Contact Size/ Current rating	12 (23A)	n° 10-8 (46A) n° 4-16 (13A)	n° 8-4 (80A) n° 6-12 (23A)
Service Rating	A 700 Vdc 500 Vac	D 1250 Vdc 900 Vac	A 700 Vdc 500 Vac
Grommet	-	●	●

15 CONTACTS

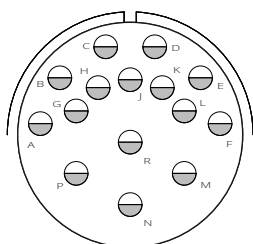

Insert Arrangement	28-17**	
N° of Contacts	15	
Contact Size/ Current rating	16 (13A)	
Service Rating	M,N,P=D - R=B - Bal.=A	
Grommet	-	

16 CONTACTS

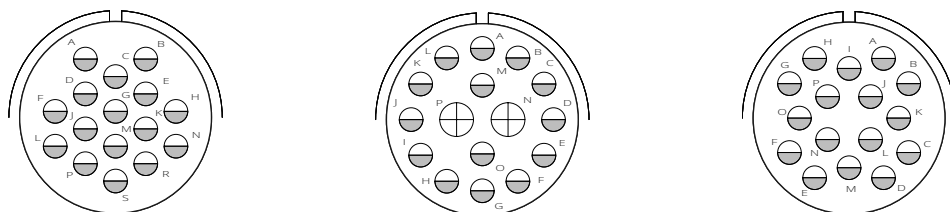

Insert Arrangement	24-5	24-7	24A16 (L)
N° of Contacts	16	16	16
Contact Size/ Current rating	16 (13A)	n° 2-12 (23A) n° 14-16 (13A)	16 (13A)
Service Rating	A 700 Vdc 500 Vac	A 700 Vdc 500 Vac	D 1250 Vdc 900 Vac
Grommet	●	●	-

● Grommet Available

** On request (please consult our Sales Office)

(L) Long Insert

(S) Short Insert

(NS) Non Standard Shell Type

Front view Pin contacts insert

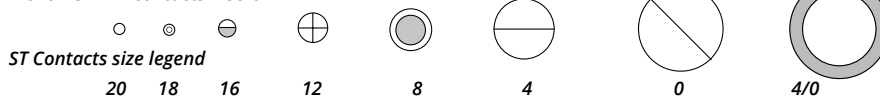

ST Contacts size legend

20 18 16 12 8 4 0 4/0

Insulating Inserts and Grommets - List by contacts total quantity

CVS-CVB-CVBS-CVBSG-CVBR - Inserts Arrangement

16 CONTACTS

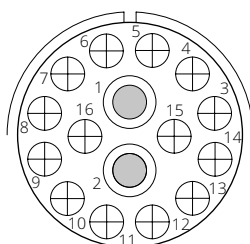

NEW

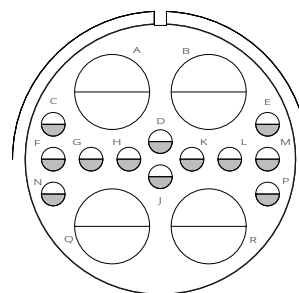

Insert Arrangement	28A16	32-68
N° of Contacts	16	16
Contact Size/ Current rating	n° 2-8 (46A) n° 14-12 (23A)	n° 4-4 (80A) n° 12-16 (13A)
Service Rating	A 700 Vdc 500 Vac	A 700 Vdc 500 Vac
Grommet	●	-

17 CONTACTS

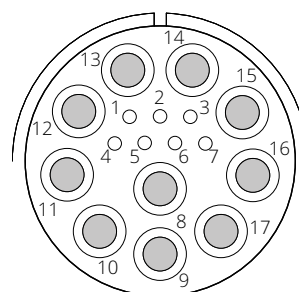
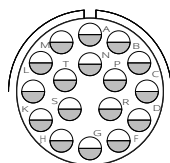

Insert Arrangement	20-29	32A17**
N° of Contacts	17	17
Contact Size/ Current rating	16 (13A)	n° 10-8 (46A) n° 7-20 (7.5A)
Service Rating	A 700 Vdc 500 Vac	A 700 Vdc 500 Vac
Grommet	●	-

19 CONTACTS

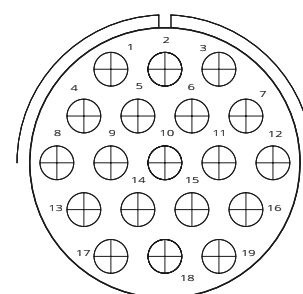
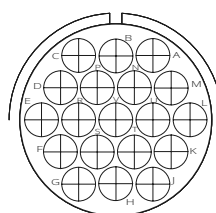
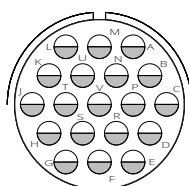
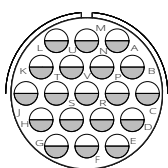

Insert Arrangement	20A48	22-14	24-67	32-76**
N° of Contacts	19	19	19	19
Contact Size/ Current rating	16 (13A)	16 (13A)	12 (23A)	12 (23A)
Service Rating	I 250 Vdc 200 Vac	A 700 Vdc 500 Vac	A 700 Vdc 500 Vac	A 700 Vdc 500 Vac
Grommet	●	●	-	-

● Grommet Available

** On request (please consult our Sales Office)

(L) Long Insert

(S) Short Insert

(NS) Non Standard Shell Type

Front view Pin contacts insert

ST Contacts size legend

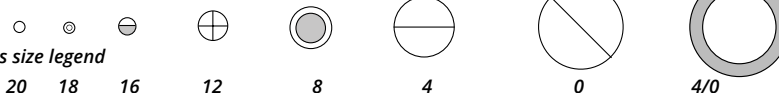

Insulating Inserts and Grommets - List by contacts total quantity

CVS-CVB-CVBS-CVBSG-CVBR - Inserts Arrangement

20 CONTACTS

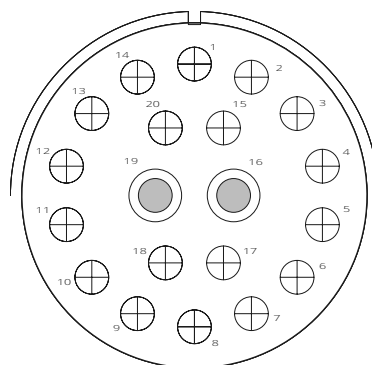
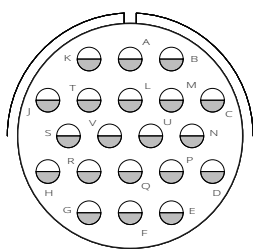

Insert Arrangement	28-16	40A20
N° of Contacts	20	20
Contact Size/ Current rating	16 (13A)	n° 2-8 (46A) n° 18-12 (23A)
Service Rating	A 700 Vdc 500 Vac	D 1250 Vdc 900 Vac
Grommet	●	●

22 CONTACTS

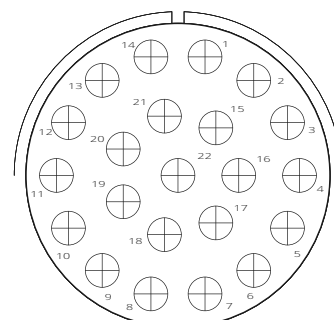
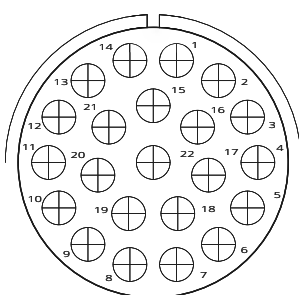
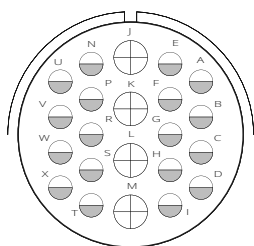

Insert Arrangement	28-11	32A22	36A22
N° of Contacts	22	22	22
Contact Size/ Current rating	n° 4-12 (23A) n° 18-16 (13A)	12 (23A)	12 (23A)
Service Rating	A 700 Vdc 500 Vac	A 700 Vdc 500 Vac	D 1250 Vdc 900 Vac
Grommet	●	-	●

23 CONTACTS

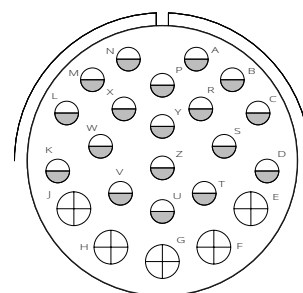
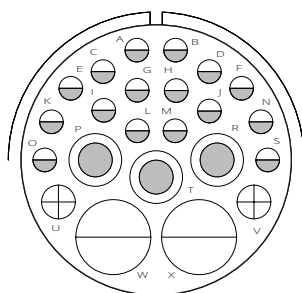

Insert Arrangement	32-6**	32-13
N° of Contacts	23	23
Contact Size/ Current rating	n° 3-4 (80A) - n° 2-8 (46A) n° 2-12 (23A) - n° 16-16 (13A)	n° 5-12 (23A) n° 18-16 (13A)
Service Rating	A 700 Vdc 500 Vac	D 1250 Vdc 900 Vac
Grommet	●	-

● Grommet Available

** On request (please consult our Sales Office)

(L) Long Insert

(S) Short Insert

(NS) Non Standard Shell Type

Front view Pin contacts insert

ST Contacts size legend

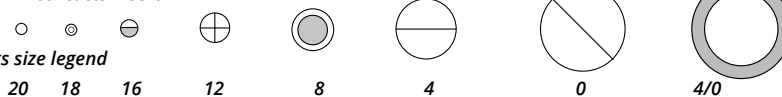

Insulating Inserts and Grommets - List by contacts total quantity

CVS-CVB-CVBS-CVBSG-CVBR - Inserts Arrangement

24 CONTACTS

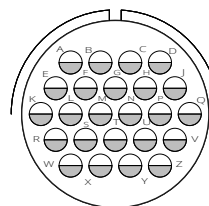
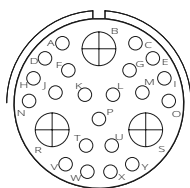

Insert Arrangement	22A24	24-28
N° of Contacts	24	24
Contact Size/ Current rating	n° 3-12 (23A) n° 21-20 (7.5A)	16 (13A)
Service Rating	A 700 Vdc 500 Vac	I 250 Vdc 200 Vac
Grommet	-	●

25 CONTACTS

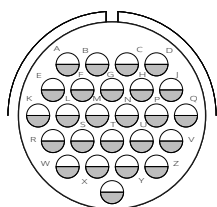

NEW

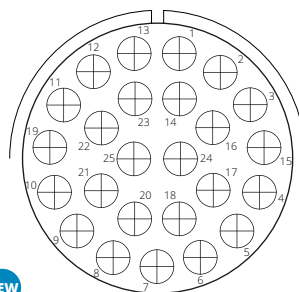

NEW

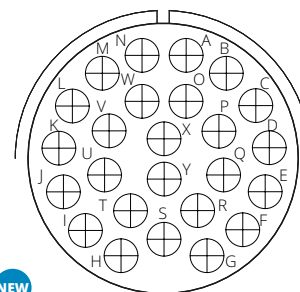

Insert Arrangement	24A25	32A25	32B25
N° of Contacts	25	25	25
Contact Size/ Current rating	16 (13A)	12 (23A)	12 (23A)
Service Rating	I 250 Vdc 200 Vac	A 700 Vdc 500 Vac	A 700 Vdc 500 Vac
Grommet	●	●	-

25 CONTACTS

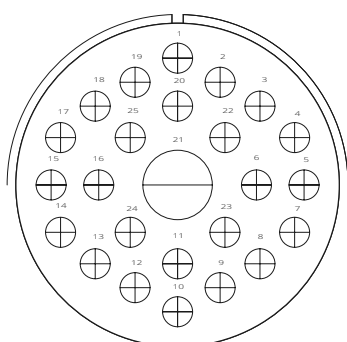

26 CONTACTS

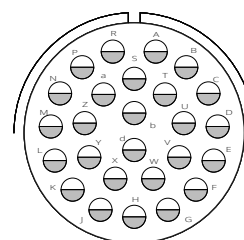

Insert Arrangement	40A25	28-12
N° of Contacts	25	26
Contact Size/ Current rating	n° 1-4 (80A) n° 24-12 (23A)	16 (13A)
Service Rating	A 700 Vdc 500 Vac	A 700 Vdc 500 Vac
Grommet	●	●

● Grommet Available

** On request (please consult our Sales Office)

(L) Long Insert

(S) Short Insert

(NS) Non Standard Shell Type

Front view Pin contacts insert

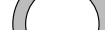

ST Contacts size legend

20

18

16

12

8

4

0

4/0

Insulating Inserts and Grommets - List by contacts total quantity

CVS-CVB-CVBS-CVBSG-CVBR - Inserts Arrangement

28 CONTACTS

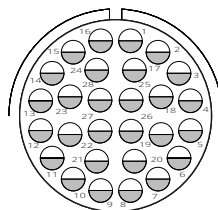

Insert Arrangement	24A28
N° of Contacts	28
Contact Size/ Current rating	16 (13A)
Service Rating	I 250 Vdc 200 Vac
Grommet	●

29 CONTACTS

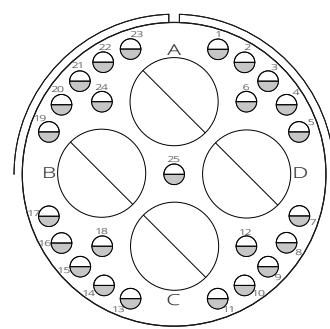
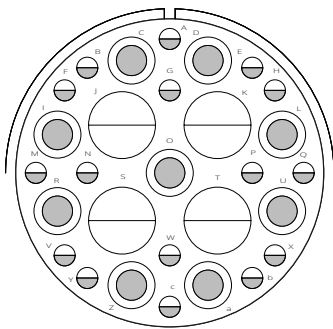

Insert Arrangement	40-10	40B25
N° of Contacts	29	29
Contact Size/ Current rating	n° 4-4 (80A) - n° 9-8 (46A) n° 16-16 (13A)	n° 4-0 (150A) n° 25-16 (13A)
Service Rating	A 700 Vdc 500 Vac	A 700 Vdc 500 Vac
Grommet	●	●

30 CONTACTS

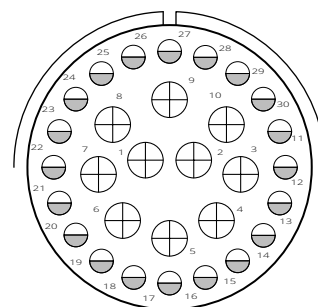
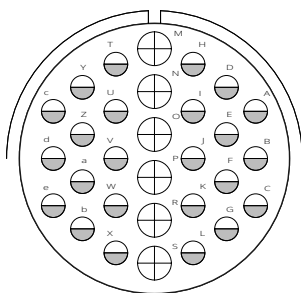

Insert Arrangement	32-8	32A30
N° of Contacts	30	30
Contact Size/ Current rating	n° 6-12 (23A) n° 24-16 (13A)	n° 10-12 (23A) n° 20-16 (13A)
Service Rating	A 700 Vdc 500 Vac	A 700 Vdc 500 Vac
Grommet	●	●

● Grommet Available

** On request (please consult our Sales Office)

(L) Long Insert

(S) Short Insert

(NS) Non Standard Shell Type

Front view Pin contacts insert

ST Contacts size legend

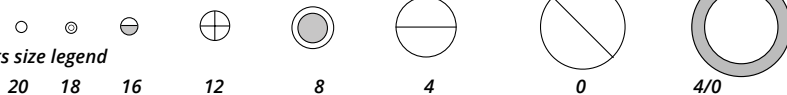

Insulating Inserts and Grommets - List by contacts total quantity

CVS-CVB-CVBS-CVBSG-CVBR - Inserts Arrangement

31 CONTACTS

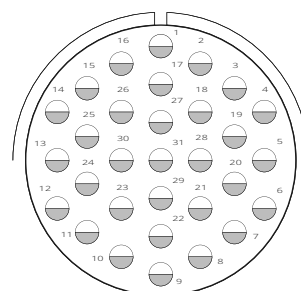
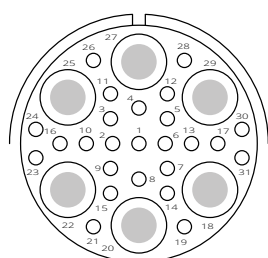

Insert Arrangement	28A31 (L)	32-31
N° of Contacts	31	31
Contact Size/ Current rating	n° 6-8 (46A) n° 25-20 (7.5A)	16 (13A)
Service Rating	A 700 Vdc 500 Vac	A 700 Vdc 500 Vac
Grommet	-	-

31 CONTACTS

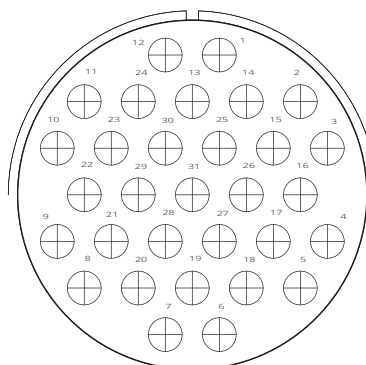
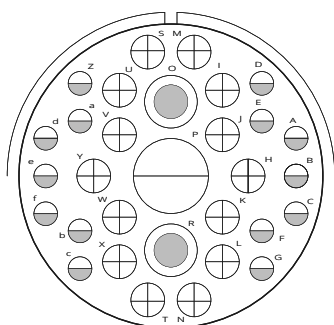

Insert Arrangement	36-9**	40A31
N° of Contacts	31	31
Contact Size/ Current rating	n° 1-4 (80A) - n° 2-8 (46A) n° 14-12 (23A) - n° 14-16 (13A)	12 (23A)
Service Rating	A 700 Vdc 500 Vac	D 1250 Vdc 900 Vac
Grommet	-	●

34 CONTACTS

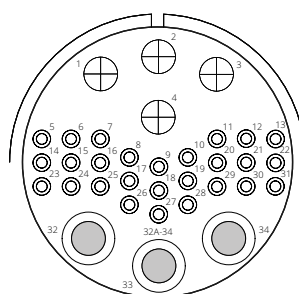

Insert Arrangement	32A34
N° of Contacts	34
Contact Size/ Current rating	n° 3-8 (46A) n° 4-12 (23A) - n° 27-18 (7.5A)
Service Rating	1,2,3,4=A - Bal.=I
Grommet	-

● Grommet Available

** On request (please consult our Sales Office)

(L) Long Insert

(S) Short Insert

(NS) Non Standard Shell Type

Front view Pin contacts insert

ST Contacts size legend

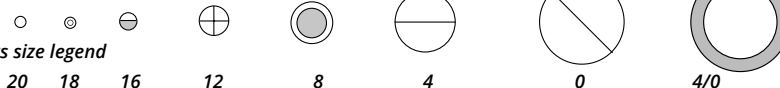

Insulating Inserts and Grommets - List by contacts total quantity

CVS-CVB-CVBS-CVBSG-CVBR - Inserts Arrangement

35 CONTACTS

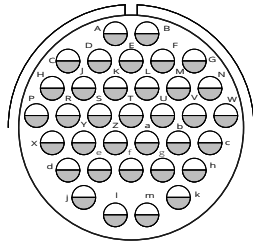

NEW

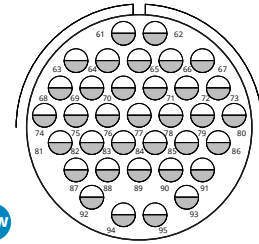

Insert Arrangement	28-15	28A35
N° of Contacts	35	35
Contact Size/ Current rating	16 (13A)	16 (13A)
Service Rating	A 700 Vdc 500 Vac	A 700 Vdc 500 Vac
Grommet	●	●

35 CONTACTS

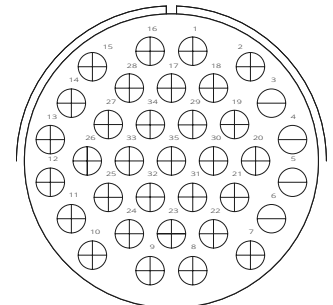
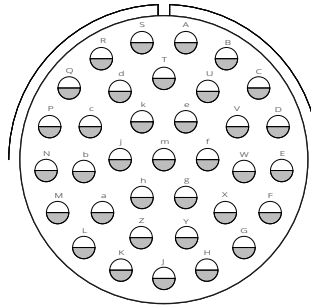
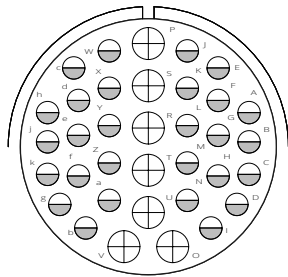

Insert Arrangement	32-7	36-15	40A35
N° of Contacts	35	35	35
Contact Size/ Current rating	n° 7-12 (23A) n° 28-16 (13A)	16 (13A)	12 (23A)
Service Rating	A,B,h,j=l - Bal.=A	M=D - Bal.=A	D 1250 Vdc 900 Vac
Grommet	●	●	●

37 CONTACTS

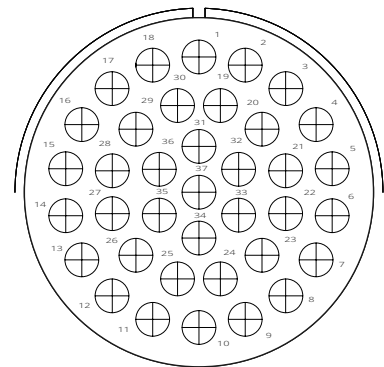
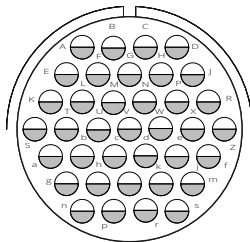

Insert Arrangement	28-21	40B37
N° of Contacts	37	37
Contact Size/ Current rating	16 (13A)	12 (23A)
Service Rating	A 700 Vdc 500 Vac	A 700 Vdc 500 Vac
Grommet	-	●

● Grommet Available

** On request (please consult our Sales Office)

(L) Long Insert

(S) Short Insert

(NS) Non Standard Shell Type

Front view Pin contacts insert

ST Contacts size legend

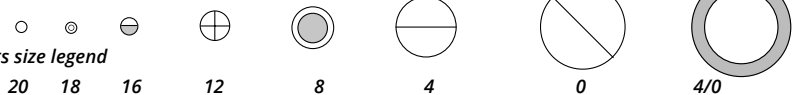

Insulating Inserts and Grommets - List by contacts total quantity

CVS-CVB-CVBS-CVBSG-CVBR - Inserts Arrangement

38 CONTACTS

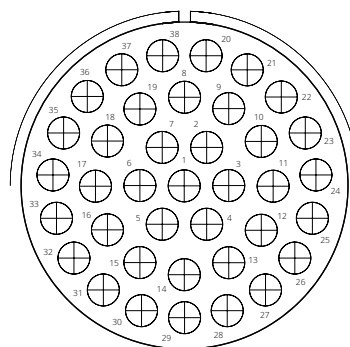

NEW

Insert Arrangement		40A38
N° of Contacts		38
Contact Size/ Current rating		12 (23A)
Service Rating		A 700 Vdc 500 Vac
Grommet		●

39 CONTACTS

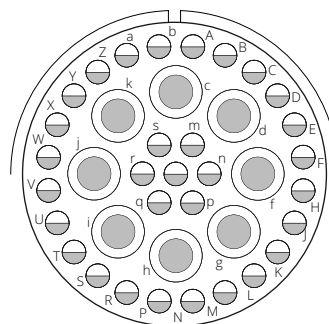

NEW

Insert Arrangement		36B39
N° of Contacts		39
Contact Size/ Current rating		n° 8-8 (46A) n° 31-16 (13A)
Service Rating		A 700 Vdc 500 Vac
Grommet		●

42 CONTACTS

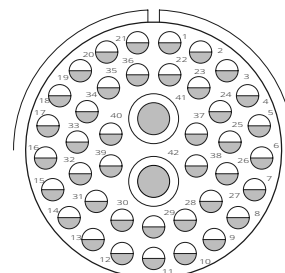

Insert Arrangement		32-59
N° of Contacts		42
Contact Size/ Current rating		n° 2-8 (46A) n° 40-16 (13A)
Service Rating		A 700 Vdc 500 Vac
Grommet		●

● Grommet Available

** On request (please consult our Sales Office)

(L) Long Insert

(S) Short Insert

(NS) Non Standard Shell Type

Front view Pin contacts insert

ST Contacts size legend

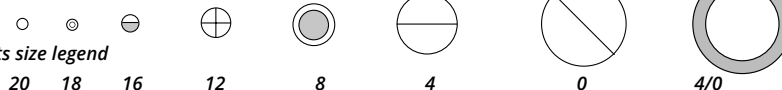

Insulating Inserts and Grommets - List by contacts total quantity

CVS-CVB-CVBS-CVBSG-CVBR - Inserts Arrangement

47 CONTACTS

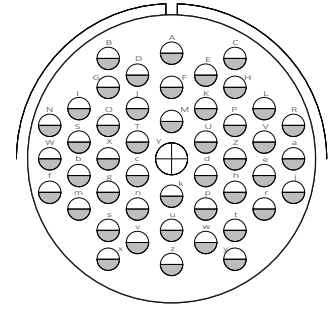
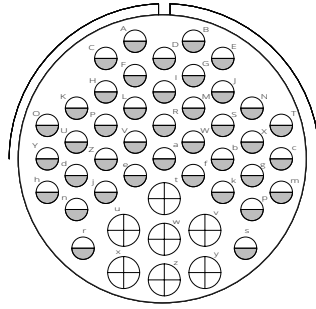

Insert Arrangement	36-7	36-8**
N° of Contacts	47	47
Contact Size/ Current rating	n° 7-12 (23A) n° 40-16 (13A)	n° 1-12 (23A) n° 46-16 (13A)
Service Rating	A 700 Vdc 500 Vac	A 700 Vdc 500 Vac
Grommet	●	-

47 CONTACTS

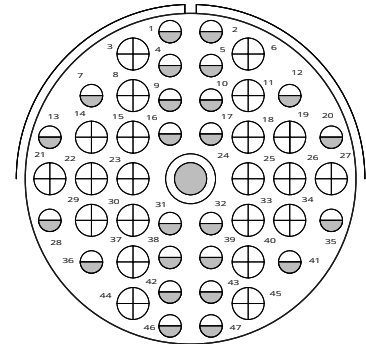
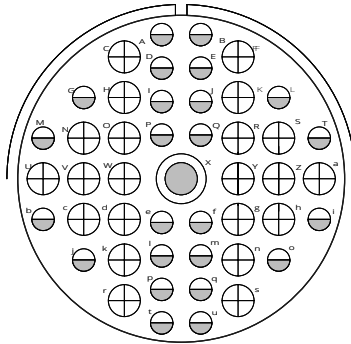

Insert Arrangement	40-9	40A47
N° of Contacts	47	47
Contact Size/ Current rating	n° 1-8 (46A) n° 22-12 (23A) n° 24-16 (13A)	n° 1-8 (46A) n° 22-12 (23A) n° 24-16 (13A)
Service Rating	A 700 Vdc 500 Vac	A 700 Vdc 500 Vac
Grommet	●	●

48 CONTACTS

NEW

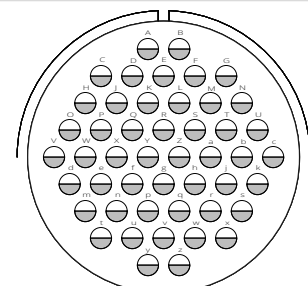
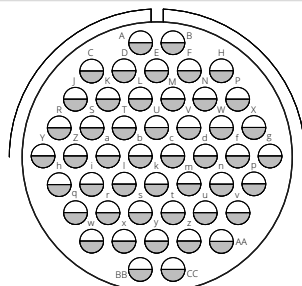

Insert Arrangement	32A48	36-10
N° of Contacts	48	48
Contact Size/ Current rating	16 (13A)	16 (13A)
Service Rating	I 250 Vdc 200 Vac	A 700 Vdc 500 Vac
Grommet	●	●

● Grommet Available
 ** On request (please consult our Sales Office)
 (L) Long Insert
 (S) Short Insert
 (NS) Non Standard Shell Type

Front view Pin contacts insert

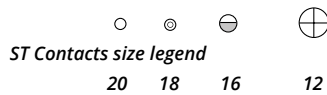

Insulating Inserts and Grommets - List by contacts total quantity

CVS-CVB-CVBS-CVBSG-CVBR - Inserts Arrangement

51 CONTACTS

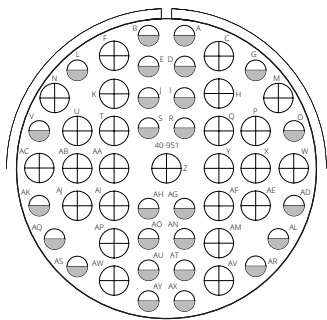

54 CONTACTS

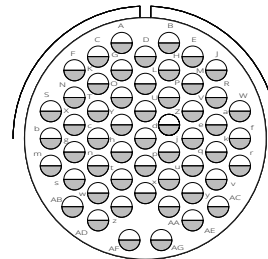

Insert Arrangement	40-951	32-22
N° of Contacts	51	54
Contact Size/ Current rating	n° 25-12 (23A) n° 26-16 (13A)	16 (13A)
Service Rating	A 700 Vdc 500 Vac	A 700 Vdc 500 Vac
Grommet	●	●

55 CONTACTS

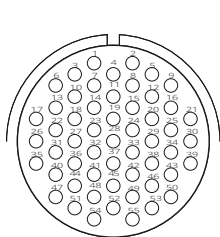

56 CONTACTS

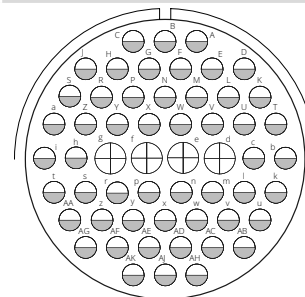
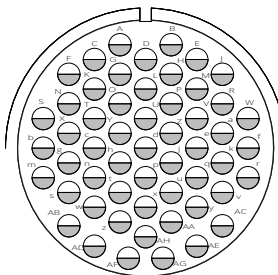

Insert Arrangement	24A55 (S)	32A55	36-66
N° of Contacts	55	55	56
Contact Size/ Current rating	20 (7.5A)	16 (13A)	n° 4-12 (23A) n° 52-16 (13A)
Service Rating	I 250 Vdc 200 Vac	A 700 Vdc 500 Vac	A 700 Vdc 500 Vac
Grommet	-	●	●

60 CONTACTS

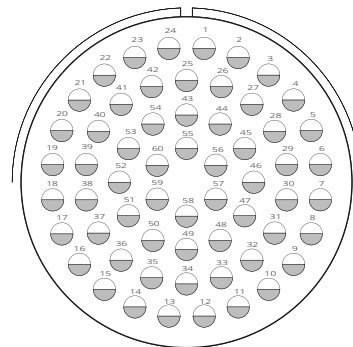
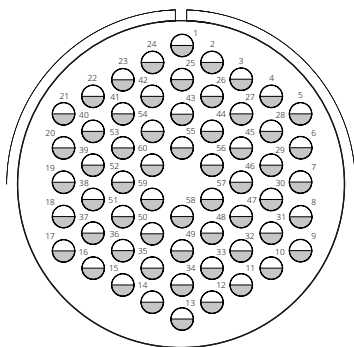

Insert Arrangement	40-62	40A60**
N° of Contacts	60	60
Contact Size/ Current rating	16 (13A)	16 (13A)
Service Rating	A 700 Vdc 500 Vac	A 700 Vdc 500 Vac
Grommet	●	●

● Grommet Available

** On request (please consult our Sales Office)

(L) Long Insert

(S) Short Insert

(NS) Non Standard Shell Type

Front view Pin contacts insert

ST Contacts size legend

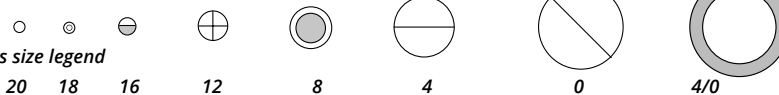

Insulating Inserts and Grommets - List by contacts total quantity

CVS-CVB-CVBS-CVBSG-CVBR - Inserts Arrangement

61 CONTACTS

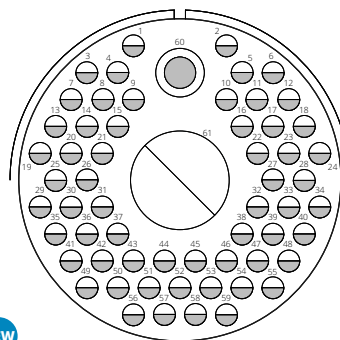
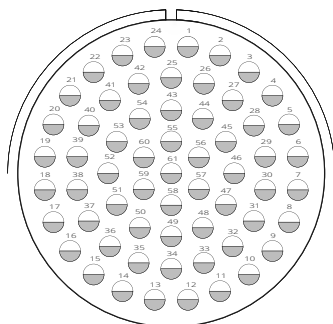

Insert Arrangement	40-63	40A61
N° of Contacts	61	61
Contact Size/ Current rating	16 (13A)	n° 1-0 (150A) - n° 1-8 (46A) n° 59-16 (13A)
Service Rating	A 700 Vdc 500 Vac	A 700 Vdc 500 Vac
Grommet	●	●

62 CONTACTS

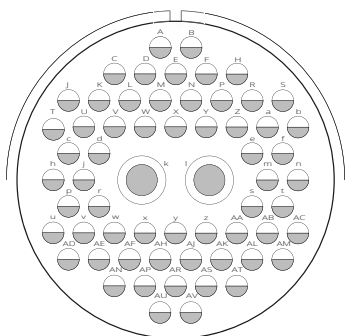

65 CONTACTS

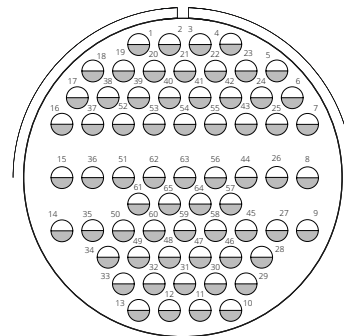

Insert Arrangement	40A62	40A65
N° of Contacts	62	65
Contact Size/ Current rating	n° 2-8 (46A) n° 60-16 (13A)	16 (13A)
Service Rating	A 700 Vdc 500 Vac	A 700 Vdc 500 Vac
Grommet	-	●

70 CONTACTS

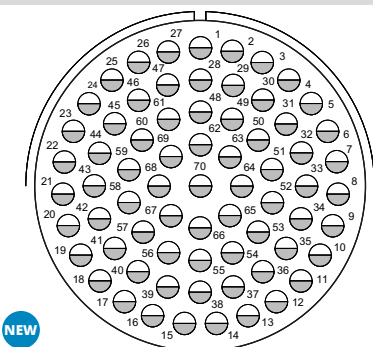

72 CONTACTS

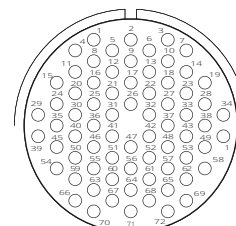

Insert Arrangement	40A70	28-72 (S)
N° of Contacts	70	72
Contact Size/ Current rating	16 (13A)	20 (7.5A)
Service Rating	A 700 Vdc 500 Vac	I 250 Vdc 200 Vac
Grommet	●	-

● Grommet Available

** On request (please consult our Sales Office)

(L) Long Insert

(S) Short Insert

(NS) Non Standard Shell Type

Front view Pin contacts insert

ST Contacts size legend

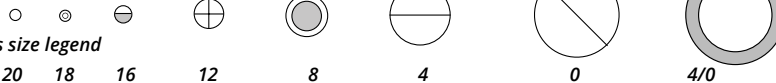

Insulating Inserts and Grommets - List by contacts total quantity

CVS-CVB-CVBS-CVBSG-CVBR - Inserts Arrangement

85 CONTACTS

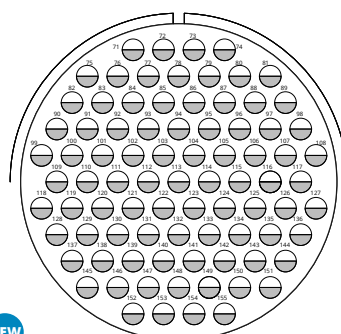
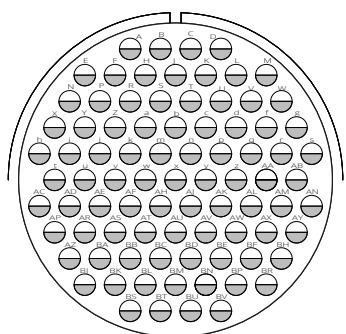

NEW

Insert Arrangement	40-56	40A56
N° of Contacts	85	85
Contact Size/ Current rating	16 (13A)	16 (13A)
Service Rating	A 700 Vdc 500 Vac	A 700 Vdc 500 Vac
Grommet	●	●

100 CONTACTS

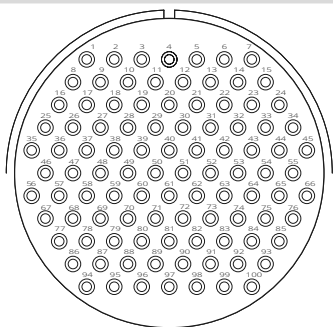

101 CONTACTS

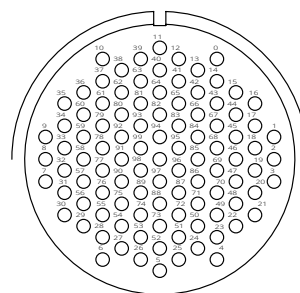

Insert Arrangement	40A100	32A101 (S)
N° of Contacts	100	101
Contact Size/ Current rating	18 (7.5A)	20 (7.5A)
Service Rating	A 700 Vdc 500 Vac	I 250 Vdc 200 Vac
Grommet	-	-

150 CONTACTS

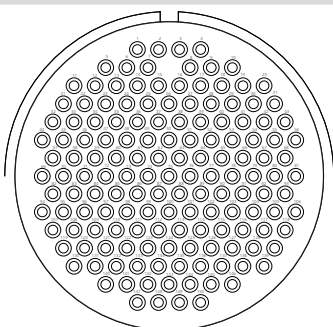

201 CONTACTS

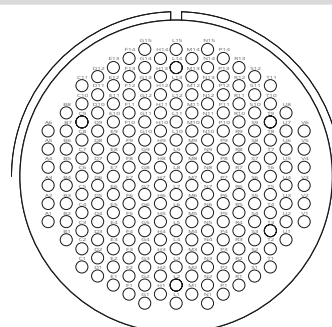

Insert Arrangement	40A150	40A201
N° of Contacts	150	201
Contact Size/ Current rating	18 (7.5A)	20 (7.5A)
Service Rating	I 250 Vdc 200 Vac	I 250 Vdc 200 Vac
Grommet	-	-

● Grommet Available

** On request (please consult our Sales Office)

(L) Long Insert

(S) Short Insert

(NS) Non Standard Shell Type

Front view Pin contacts insert

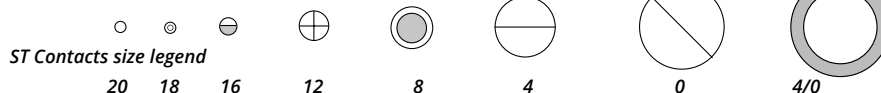

ST Contacts size legend

20 18 16 12 8 4 0 4/0

Insulating Inserts and Grommets - List by contacts total quantity

GVJ - Inserts Arrangement

4 CONTACTS

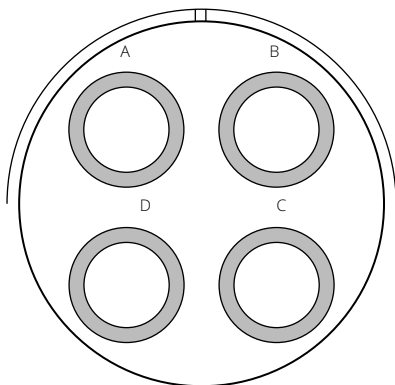

Insert Arrangement	48A4*
N° of Contacts	4
Contact Size/ Current rating/ Contact Type	4/0 (225A) - KT Contacts
Service Rating	D 1250 Vdc 900 Vac
Grommet	●

● Grommet Available

6 CONTACTS

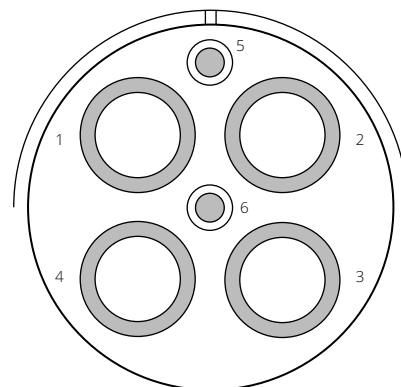
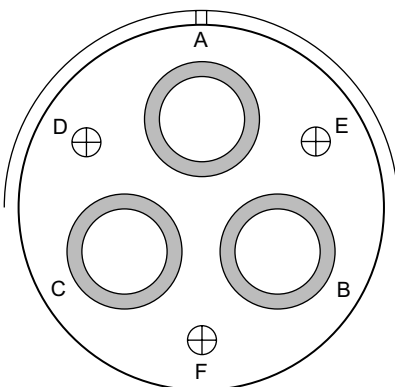

Insert Arrangement	48-6 (L)	48A7*
N° of Contacts	6	6
Contact Size/ Current rating/ Contact Type	n°3-4/0 (225A) - ST Contacts n°3-12 (23A) - ST Contacts	n°4-4/0 (225A) - KT Contacts n°2-8 (46A) - KT Contacts
Service Rating	A 700 Vdc 500 Vac	A 700 Vdc 500 Vac

ST Contacts for rubber inserts
KT Contacts for thermoplastic inserts

Front view Pin contacts insert

* Thermoplastic material

(L) Long Insert

Contacts size legend

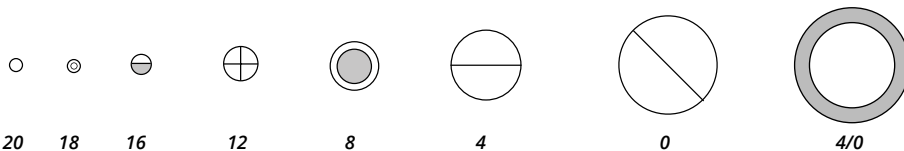

Insulating Inserts and Grommets - List by contacts total quantity

GVJ - Inserts Arrangement

9 CONTACTS

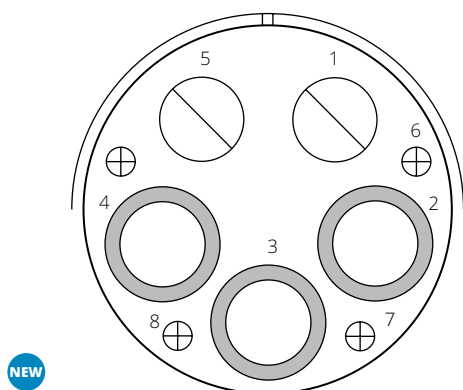

Insert Arrangement	48A9 (L)S
N° of Contacts	9
Contact Size/ Current rating/ Contact Type	n°3-4/0 (225A) - ST Contacts n°2-0 (150A) - ST Contacts n°4-12 (23A) - ST Contacts
Rating Voltage	(PD4 OV3) 400V

58 CONTACTS

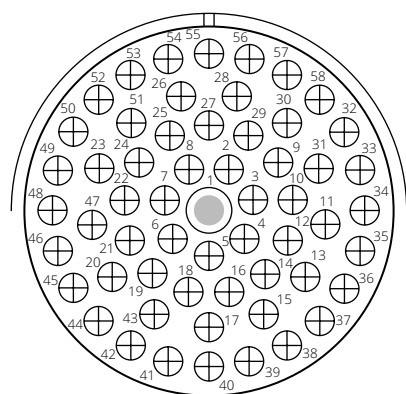

101 CONTACTS

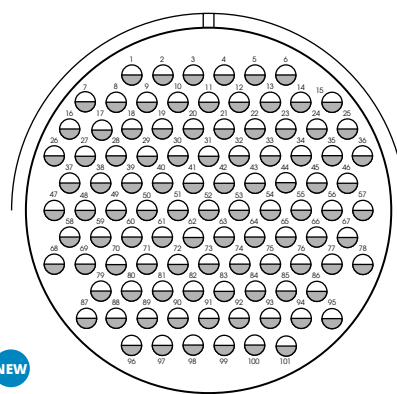

Insert Arrangement	48A58	48A101
N° of Contacts	58	101
Contact Size/ Current rating/ Contact Type	n°1-8 (46A) - ST Contacts n°57-12 (23A) - ST Contacts	16 (13A) - ST Contacts
Service Rating	A 700 Vdc 500 Vac	A 700 Vdc 500 Vac

ST Contacts for rubber inserts
KT Contacts for thermoplastic inserts

Front view Pin contacts insert

* Thermoplastic material

(L) Long Insert

Contacts size legend

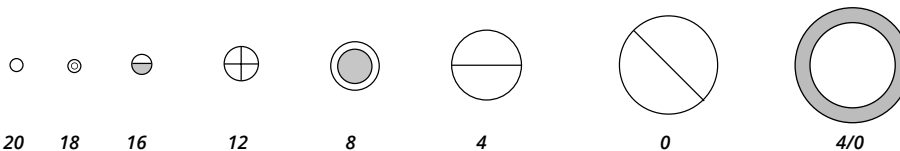

Insulating Inserts and Grommets - List by Shell size

CVS-CVB-CVBS-CVBSG-CVBR - Inserts Arrangement

	Grommet	Inserts Arrangement	N° of Contacts	Contacts Size/Current Rating								Service Rating
				4/0 225A	0 150A	4 80A	8 46A	12 23A	16 13A	18 7.5A	20 7.5A	
	●	10SL-3 *	3							3		A (700 Vdc - 500 Vac)
	●	10SL-4 *	2							2		A (700 Vdc - 500 Vac)
***		14S-1 *	3							3		A (700 Vdc - 500 Vac)
	●	14S-2 *	4							4		I (250 Vdc - 200 Vac)
	●	14S-5 *	5							5		I (250 Vdc - 200 Vac)
	●	14S-6 *	6							6		I (250 Vdc - 200 Vac)
	●	14S-7 *	3							3		A (700 Vdc - 500 Vac)
	●	14S-9 *	2							2		A (700 Vdc - 500 Vac)
	●	14SA7 *	7							7		I (250 Vdc - 200 Vac)
	●	16S-1 *	7							7		A (700 Vdc - 500 Vac)
	●	16S-4 *	2							2		D (1250 Vdc - 900 Vac)
	●	16S-5 *	3							3		A (700 Vdc - 500 Vac)
		16S-8 *	5							5		A (700 Vdc - 500 Vac)
**		16-2	1						1			E (1750 Vdc - 1250 Vac)
**		16-7	3					1		2		A (700 Vdc - 500 Vac)
		16-9	4						2	2		A (700 Vdc - 500 Vac)
	●	16-10	3						3			A (700 Vdc - 500 Vac)
**		16-11	2						2			A (700 Vdc - 500 Vac)
●		16-12	1				1					A (700 Vdc - 500 Vac)
		16A5	5						2	3		A (700 Vdc - 500 Vac)
**		16A10	10								10	A (700 Vdc - 500 Vac)
	●	18-1	10							10		B,C,F,G=A - Bal.=i
		18-3	2						2			D (1250 Vdc - 900 Vac)
	●	18-4	4							4		D (1250 Vdc - 900 Vac)
		18-5	3						2	1		D (1250 Vdc - 900 Vac)
●		18-06	6						4	2		A (700 Vdc - 500 Vac)
●		18-6	1				1					D (1250 Vdc - 900 Vac)
		18-8	8						1	7		A (700 Vdc - 500 Vac)
		18-9	7						2	5		I (250 Vdc - 200 Vac)
	●	18-10	4						4			A (700 Vdc - 500 Vac)
	●	18-11	5						5			A (700 Vdc - 500 Vac)
	●	18-12	6							6		A (700 Vdc - 500 Vac)
**		18-13	4					1	3			A (700 Vdc - 500 Vac)
**		18-14	2					1		1		A (700 Vdc - 500 Vac)
**		18-16	1						1			C (4200 Vdc - 3000 Vac)
	●	18-19	10							10		A (700 Vdc - 500 Vac)
	●	18-20	5							5		A (700 Vdc - 500 Vac)
	●	18-22	3							3		D (1250 Vdc - 900 Vac)
	L	18A5	5							5		D (1250 Vdc - 900 Vac)
●		20-2	1				1					D (1250 Vdc - 900 Vac)
	●	20-3	3							3		D (1250 Vdc - 900 Vac)
	●	20-4	4							4		D (1250 Vdc - 900 Vac)
	●	20-7	8							8		A,B,H,G=D - Bal.=A
**	NS	20-8	6					2		4		I (250 Vdc - 200 Vac)
		20-11	13							13		I (250 Vdc - 200 Vac)

● New insert * To be used with 16S contacts size (L) Long Insert (S) Short Insert
 ● Grommet Available ** On request (please consult our Sales Office) (NS) Non Standard Shell Type
 *** Same as 14S-7S (it is different from MIL-STD-1651 specs)

Insulating Inserts and Grommets - List by Shell size

CVS-CVB-CVBS-CVBSG-CVBR - Inserts Arrangement

	Grommet	Inserts Arrangement	N° of Contacts	Contacts Size/Current Rating								Service Rating
				4/0 225A	0 150A	4 80A	8 46A	12 23A	16 13A	18 7.5A	20 7.5A	
		●	20-15	7					7			A (700 Vdc - 500 Vac)
**			20-16	9					2	7		A (700 Vdc - 500 Vac)
**			20-17	6					5	1		A (700 Vdc - 500 Vac)
		●	20-18	9					3	6		A (700 Vdc - 500 Vac)
		●	20-19	3			3					A (700 Vdc - 500 Vac)
			20-21	9					1	8		A (700 Vdc - 500 Vac)
**			20-22	6			3		3			A (700 Vdc - 500 Vac)
**			20-23	2			2					A (700 Vdc - 500 Vac)
			20-24	4			2		2			A (700 Vdc - 500 Vac)
		●	20-27	14						14		A (700 Vdc - 500 Vac)
		●	20-29	17						17		A (700 Vdc - 500 Vac)
		●	20-33	11						11		A (700 Vdc - 500 Vac)
		●	20A48	19						19		I (250 Vdc - 200 Vac)
			20B8	8					4	4		A (700 Vdc - 500 Vac)
		●	22-1	2			2					D (1250 Vdc - 900 Vac)
	NS	●	22-2	3			3					D (1250 Vdc - 900 Vac)
**			22-4	4			2	2				A (700 Vdc - 500 Vac)
**			22-5	6				2	4			D (1250 Vdc - 900 Vac)
**			22-6	3			2		1			D (1250 Vdc - 900 Vac)
**			22-7	1		1						E (1750 Vdc - 1250 Vac)
**			22-8	2				2				E (1750 Vdc - 1250 Vac)
**		●	22-9	3				3				E (1750 Vdc - 1250 Vac)
**			22-11	2						2		B (2450 Vdc - 1750 Vac)
**	NS		22-12	5			2		3			D (1250 Vdc - 900 Vac)
		●	22-14	19						19		A (700 Vdc - 500 Vac)
**			22-15	6					5	1		D=E - Bal.=A
**			22-17	9					1	8		A=D - Bal.=A
		●	22-18	8						8		A,B,F,G,H=D - Bal.=A
**	NS	●	22-19	14						14		A (700 Vdc - 500 Vac)
		●	22-21	3		1				2		A (700 Vdc - 500 Vac)
		●	22-22	4			4					A (700 Vdc - 500 Vac)
		●	22-23	8					8			H=D - Bal.=A
**			22-28	7					7			A (700 Vdc - 500 Vac)
●	L	●	22A1	1		1						750V (according to APTA SS-E-001-98)
●	L	●	22A3	3					3			B (2450 Vdc - 1750 Vac)
		●	22A10	10						10		A (700 Vdc - 500 Vac)
			22A24	24					3		21	A (700 Vdc - 500 Vac)
		●	24-2	7					7			D (1250 Vdc - 900 Vac)
		●	24-5	16						16		A (700 Vdc - 500 Vac)
**			24-6	8					8			A,G,H=D - Bal.=A
		●	24-7	16					2	14		A (700 Vdc - 500 Vac)
		●	24-9	2			2					A (700 Vdc - 500 Vac)
		●	24-10	7			7					A (700 Vdc - 500 Vac)
		●	24-11	9				3	6			A (700 Vdc - 500 Vac)
●		●	24-12/1	3				3				A (700 Vdc - 500 Vac)

● New insert

● Grommet Available

** On request (please consult our Sales Office)

(L) Long Insert

(NS) Non Standard Shell Type

(S) Short Insert

Insulating Inserts and Grommets - List by Shell size

CVS-CVB-CVBS-CVBSG-CVBR - Inserts Arrangement

	Grommet	Inserts Arrangement	N° of Contacts	Contacts Size/Current Rating								Service Rating
				4/0 225A	0 150A	4 80A	8 46A	12 23A	16 13A	18 7.5A	20 7.5A	
			24-12	5			2		3			A (700 Vdc - 500 Vac)
	●		24-19	12						12		A (700 Vdc - 500 Vac)
	●		24-20	11					2	9		D (1250 Vdc - 900 Vac)
**			24-21	10				1		9		D (1250 Vdc - 900 Vac)
	●		24-22	4				4				D (1250 Vdc - 900 Vac)
	●		24-27	7						7		E (1750 Vdc - 1250 Vac)
	●		24-28	24						24		I (250 Vdc - 200 Vac)
**			24-06	6				4		2		D (1250 Vdc - 900 Vac)
			24-67	19					19			A (700 Vdc - 500 Vac)
**			24A7	7					7			D (1250 Vdc - 900 Vac)
	L		24A16	16						16		D (1250 Vdc - 900 Vac)
		●	24A25	25						25		I (250 Vdc - 200 Vac)
		●	24A28	28						28		I (250 Vdc - 200 Vac)
	S		24A55	55							55	I (250 Vdc - 200 Vac)
		●	28-1	9				3	6			A,J,E=D - Bal.=A
			28-2	14					2	12		D (1250 Vdc - 900 Vac)
		●	28-3	3				3				E (1750 Vdc - 1250 Vac)
			28-5	5			2		1	2		D (1250 Vdc - 900 Vac)
		●	28-6	3			3					D (1250 Vdc - 900 Vac)
**			28-9	12					6	6		D (1250 Vdc - 900 Vac)
			28-10	7			2	2	3			G=D - Bal.=A
		●	28-11	22					4	18		A (700 Vdc - 500 Vac)
		●	28-12	26						26		A (700 Vdc - 500 Vac)
		●	28-15	35						35		A (700 Vdc - 500 Vac)
		●	28-16	20						20		A (700 Vdc - 500 Vac)
**			28-17	15						15		M,N,P=D - R=B - Bal.=A
		●	28-18	12						12		M=C - A,B=A - G,H,J,K,L=D - Bal.=I
**			28-19	10					4	6		H,M=B - A,B=D - Bal.=A
**			28-20	14					10	4		A (700 Vdc - 500 Vac)
		●	28-21	37						37		A (700 Vdc - 500 Vac)
			28-22	6			3			3		D (1250 Vdc - 900 Vac)
	L	●	28-51	12					12			D (1250 Vdc - 900 Vac)
	S		28-72	72							72	I (250 Vdc - 200 Vac)
●	L		28A1	1	1							750V OV4 PD4
●	L	●	28A3	3				3				B (2450 Vdc - 1750 Vac)
			28A9	9			4			5		A (700 Vdc - 500 Vac)
			28A14	14					14			D (1250 Vdc - 900 Vac)
●		●	28A16	16				2	14			A (700 Vdc - 500 Vac)
	L		28A31	31				6			25	A (700 Vdc - 500 Vac)
●		●	28A35	35						35		A (700 Vdc - 500 Vac)
●	L	●	28B8	8					8			750V (according to APTA SS-E-001-98)
		●	32-1	5		2			3			A=E - Bal.=D
**			32-2	5			3			2		E (1750 Vdc - 1250 Vac)
		●	32-5	2		2						D (1250 Vdc - 900 Vac)
**		●	32-6	23			2	3	2	16		A (700 Vdc - 500 Vac)

● New insert

● Grommet Available

** On request (please consult our Sales Office)

(L) Long Insert

(NS) Non Standard Shell Type

(S) Short Insert

Insulating Inserts and Grommets - List by Shell size

CVS-CVB-CVBS-CVBSG-CVBR - Inserts Arrangement

	Grommet	Inserts Arrangement	N° of Contacts	Contacts Size/Current Rating								Service Rating
				4/0 225A	0 150A	4 80A	8 46A	12 23A	16 13A	18 7.5A	20 7.5A	
	●	32-7	35					7	28			A,B,h,j=l - Bal.=A
	●	32-8	30					6	24			A (700 Vdc - 500 Vac)
		32-13	23					5	18			D (1250 Vdc - 900 Vac)
		32-15	8		2			6				D (1250 Vdc - 900 Vac)
		32-17	4			4						D (1250 Vdc - 900 Vac)
	●	32-22	54						54			A (700 Vdc - 500 Vac)
		32-31	31						31			A (700 Vdc - 500 Vac)
	●	32-59	42				2		40			A (700 Vdc - 500 Vac)
		32-68	16			4			12			A (700 Vdc - 500 Vac)
**		32-76	19					19				A (700 Vdc - 500 Vac)
●	●	32-79	5			4	1					D (1250 Vdc - 900 Vac)
●	L	32A3	3			3						E (1750 Vdc - 1250 Vac)
	L	32A5	5			5						D (1250 Vdc - 900 Vac)
		32A9	9			3			6			A (700 Vdc - 500 Vac)
	●	32A13	13						13			D (1250 Vdc - 900 Vac)
**		32A17	17				10				7	A (700 Vdc - 500 Vac)
		32A22	22						22			A (700 Vdc - 500 Vac)
●	●	32A25	25						25			A (700 Vdc - 500 Vac)
	●	32A30	30						10	20		A (700 Vdc - 500 Vac)
●		32A34	34				3	4			27	1,2,3,4=A - Bal.=I
●	●	32A48	48							48		I (250 Vdc - 200 Vac)
	●	32A55	55							55		A (700 Vdc - 500 Vac)
	S	32A101	101								101	I (250 Vdc - 200 Vac)
**	●	32B13	13				13					A (700 Vdc - 500 Vac)
●		32B25	25						25			A (700 Vdc - 500 Vac)
	●	36-3	6		3				3			D (1250 Vdc - 900 Vac)
●	●	36-4	3		3							A=D - B/C=A
		36-5	4		4							A (700 Vdc - 500 Vac)
**		36-6	6		2	4						A (700 Vdc - 500 Vac)
	●	36-7	47					7	40			A (700 Vdc - 500 Vac)
**		36-8	47					1	46			A (700 Vdc - 500 Vac)
**		36-9	31			1	2	14	14			A (700 Vdc - 500 Vac)
	●	36-10	48							48		A (700 Vdc - 500 Vac)
	●	36-15	35							35		M=D - Bal.=A
●		36-66	56					4	52			A (700 Vdc - 500 Vac)
●	●	36-77	7			7						D (1250 Vdc - 900 Vac)
●	L	36A7	7			7						B (2450 Vdc - 1750 Vac)
●	L	36A10	10			2	8					A (700 Vdc - 500 Vac)
	●	36A22	22						22			D (1250 Vdc - 900 Vac)
●	●	36B39	39				8		31			A (700 Vdc - 500 Vac)
●	●	36D78	14				10		4			D (1250 Vdc - 900 Vac)
	●	40-9	47				1	22	24			A (700 Vdc - 500 Vac)
	●	40-10	29			4	9		16			A (700 Vdc - 500 Vac)
	●	40-56	85						85			A (700 Vdc - 500 Vac)
●	●	40-62	60						60			A (700 Vdc - 500 Vac)

● New insert

● Grommet Available

** On request (please consult our Sales Office)

(L) Long Insert

(NS) Non Standard Shell Type

(S) Short Insert

Insulating Inserts and Grommets - List by Shell size

CVS-CVB-CVBS-CVBSG-CVBR - Inserts Arrangement

	Grommet	Inserts Arrangement	N° of Contacts	Contacts Size/Current Rating								Service Rating
				4/0 225A	0 150A	4 80A	8 46A	12 23A	16 13A	18 7.5A	20 7.5A	
		●	40-63	61						61		A (700 Vdc - 500 Vac)
●		●	40-951	51					25	26		A (700 Vdc - 500 Vac)
	L		40A3	3			3					E (1750 Vdc - 1250 Vac)
	L		40A4	4		4						E (1750 Vdc - 1250 Vac)
			40A5	5		5						A (700 Vdc - 500 Vac)
		●	40A8	8		4				4		E (1750 Vdc - 1250 Vac)
		●	40A10	8			4			4		D (1250 Vdc - 900 Vac)
●	L		40A11	11		5			6			B,N,T3,S2,R1,≠=D - Bal.=A
		●	40A14	14			8		6			A (700 Vdc - 500 Vac)
		●	40A20	20				2	18			D (1250 Vdc - 900 Vac)
		●	40A25	25			1		24			A (700 Vdc - 500 Vac)
		●	40A31	31					31			D (1250 Vdc - 900 Vac)
		●	40A35	35					35			D (1250 Vdc - 900 Vac)
●		●	40A38	38					38			A (700 Vdc - 500 Vac)
		●	40A47	47				1	22	24		A (700 Vdc - 500 Vac)
●		●	40A56	85						85		A (700 Vdc - 500 Vac)
**		●	40A60	60						60		A (700 Vdc - 500 Vac)
●		●	40A61	61		1	1		59			A (700 Vdc - 500 Vac)
			40A62	62				2		60		A (700 Vdc - 500 Vac)
●		●	40A65	65						65		A (700 Vdc - 500 Vac)
●		●	40A70	70						70		A (700 Vdc - 500 Vac)
			40A100	100							100	A (700 Vdc - 500 Vac)
			40A150	150							150	I (250 Vdc - 200 Vac)
			40A201	201							201	I (250 Vdc - 200 Vac)
	L		40B3	5		3			2			A (700 Vdc - 500 Vac)
●		●	40B6	6		5	1					A (700 Vdc - 500 Vac)
●	L	●	40B7	8			1	7				750V (according to APTA SS-E-001-98)
●		●	40B10	10			10					A (700 Vdc - 500 Vac)
●		●	40B25	29		4				25		A (700 Vdc - 500 Vac)
			40B37	37					37			A (700 Vdc - 500 Vac)
**	L		40C3	3		3						B (2450 Vdc - 1750 Vac)
●	L		40C6	6		3			3			B (2450 Vdc - 1750 Vac)
●		●	40D3	3	3							A (700 Vdc - 500 Vac)

GVJ - Inserts Arrangement

	Grommet	Inserts Arrangement	N. Total / Contacts Type	Contacts Size/Current Rating								Service Rating Code
				4/0 225A	0 150A	4 80A	8 46A	12 23A	16 13A	18 7.5A	20 7.5A	
●	L		48-6	6 / ST	3					3		A (700 Vdc - 500 Vac)
		●	48A4 *	4 / KT	4							D (1250 Vdc - 900 Vac)
●			48A7 *	6 / KT	4			2				A (700 Vdc - 500 Vac)
●	L		48A9	9 / ST	3	2			4			(PD4 OV3) 400V
			48A58	58 / ST				1	57			A (700 Vdc - 500 Vac)
●			48A101	101 / ST							101	A (700 Vdc - 500 Vac)

● New insert ST Contacts for rubber inserts * Thermoplastic material (L) Long Insert (S) Short Insert
 ● Grommet Available KT Contacts for thermoplastic inserts ** On request (please consult our Sales Office) (NS) Non Standard Shell Type

Insulating Inserts and Grommets - List by contacts total quantity

CVS-CVB-CVBS-CVBSG-CVBR - Inserts Arrangement

	Grommet	Inserts Arrangement	N° of Contacts	Contacts Size/Current Rating								Service Rating
				4/0	0	4	8	12	16	18	20	
				225A	150A	80A	46A	23A	13A	7.5A	7.5A	
**			16-2	1					1			E (1750 Vdc - 1250 Vac)
●			16-12	1		1						A (700 Vdc - 500 Vac)
●			18-6	1		1						D (1250 Vdc - 900 Vac)
**			18-16	1				1				C (4200 Vdc - 3000 Vac)
●			20-2	1	1							D (1250 Vdc - 900 Vac)
**			22-7	1	1							E (1750 Vdc - 1250 Vac)
●	L	●	22A1	1	1							750V (according to APTA SS-E-001-98)
●	L		28A1	1	1							750V OV4 PD4
		●	10SL-4 *	2					2			A (700 Vdc - 500 Vac)
		●	14S-9 *	2					2			A (700 Vdc - 500 Vac)
		●	16S-4 *	2					2			D (1250 Vdc - 900 Vac)
**			16-11	2				2				A (700 Vdc - 500 Vac)
			18-3	2				2				D (1250 Vdc - 900 Vac)
**			18-14	2		1			1			A (700 Vdc - 500 Vac)
**			20-23	2			2					A (700 Vdc - 500 Vac)
		●	22-1	2			2					D (1250 Vdc - 900 Vac)
**			22-8	2				2				E (1750 Vdc - 1250 Vac)
**			22-11	2					2			B (2450 Vdc - 1750 Vac)
		●	24-9	2		2						A (700 Vdc - 500 Vac)
		●	32-5	2	2							D (1250 Vdc - 900 Vac)
		●	10SL-3 *	3					3			A (700 Vdc - 500 Vac)
***			14S-1 *	3					3			A (700 Vdc - 500 Vac)
		●	14S-7 *	3					3			A (700 Vdc - 500 Vac)
		●	16S-5 *	3					3			A (700 Vdc - 500 Vac)
**			16-7	3			1		2			A (700 Vdc - 500 Vac)
		●	16-10	3				3				A (700 Vdc - 500 Vac)
			18-5	3				2	1			D (1250 Vdc - 900 Vac)
		●	18-22	3					3			D (1250 Vdc - 900 Vac)
		●	20-3	3				3				D (1250 Vdc - 900 Vac)
		●	20-19	3			3					A (700 Vdc - 500 Vac)
	NS	●	22-2	3			3					D (1250 Vdc - 900 Vac)
**			22-6	3			2		1			D (1250 Vdc - 900 Vac)
**		●	22-9	3				3				E (1750 Vdc - 1250 Vac)
		●	22-21	3		1			2			A (700 Vdc - 500 Vac)
●	L	●	22A3	3				3				B (2450 Vdc - 1750 Vac)
●		●	24-12/1	3			3					A (700 Vdc - 500 Vac)
		●	28-3	3			3					E (1750 Vdc - 1250 Vac)
		●	28-6	3		3						D (1250 Vdc - 900 Vac)
●	L	●	28A3	3			3					B (2450 Vdc - 1750 Vac)
●	L	●	32A3	3		3						E (1750 Vdc - 1250 Vac)
●		●	36-4	3		3						A =D - B/C=A
	L		40A3	3		3						E (1750 Vdc - 1250 Vac)
**	L		40C3	3		3						B (2450 Vdc - 1750 Vac)
●		●	40D3	3	3							A (700 Vdc - 500 Vac)
		●	14S-2 *	4					4			I (250 Vdc - 200 Vac)

● New insert

● Grommet Available

* To be used with 16S contacts size

** On request (please consult our Sales Office)

*** Same as 14S-7S (it is different from MIL-STD-1651 specs)

(L) Long Insert

(NS) Non Standard Shell Type

(S) Short Insert

Insulating Inserts and Grommets - List by contacts total quantity

CVS-CVB-CVBS-CVBSG-CVBR - Inserts Arrangement

	Grommet	Inserts Arrangement	N° of Contacts	Contacts Size/Current Rating								Service Rating
				4/0 225A	0 150A	4 80A	8 46A	12 23A	16 13A	18 7.5A	20 7.5A	
		16-9	4					2	2			A (700 Vdc - 500 Vac)
	●	18-4	4						4			D (1250 Vdc - 900 Vac)
	●	18-10	4					4				A (700 Vdc - 500 Vac)
**		18-13	4				1	3				A (700 Vdc - 500 Vac)
	●	20-4	4					4				D (1250 Vdc - 900 Vac)
		20-24	4				2	2				A (700 Vdc - 500 Vac)
**		22-4	4				2	2				A (700 Vdc - 500 Vac)
	●	22-22	4				4					A (700 Vdc - 500 Vac)
	●	24-22	4				4					D (1250 Vdc - 900 Vac)
		32-17	4			4						D (1250 Vdc - 900 Vac)
		36-5	4		4							A (700 Vdc - 500 Vac)
	L	40A4	4		4							E (1750 Vdc - 1250 Vac)
	●	14S-5 *	5						5			I (250 Vdc - 200 Vac)
		16S-8 *	5						5			A (700 Vdc - 500 Vac)
		16A5	5					2	3			A (700 Vdc - 500 Vac)
	●	18-11	5					5				A (700 Vdc - 500 Vac)
	●	18-20	5						5			A (700 Vdc - 500 Vac)
	L	18A5	5						5			D (1250 Vdc - 900 Vac)
**	NS	22-12	5				2		3			D (1250 Vdc - 900 Vac)
		24-12	5			2		3				A (700 Vdc - 500 Vac)
		28-5	5			2		1	2			D (1250 Vdc - 900 Vac)
	●	32-1	5		2			3				A =E - Bal.=D
**		32-2	5			3			2			E (1750 Vdc - 1250 Vac)
●	●	32-79	5			4	1					D (1250 Vdc - 900 Vac)
	L	32A5	5			5						D (1250 Vdc - 900 Vac)
		40A5	5		5							A (700 Vdc - 500 Vac)
	L	40B3	5		3			2				A (700 Vdc - 500 Vac)
	●	14S-6 *	6						6			I (250 Vdc - 200 Vac)
●		18-06	6					4	2			A (700 Vdc - 500 Vac)
	●	18-12	6						6			A (700 Vdc - 500 Vac)
**	NS	20-8	6				2		4			I (250 Vdc - 200 Vac)
**		20-17	6					5	1			A (700 Vdc - 500 Vac)
**		20-22	6				3		3			A (700 Vdc - 500 Vac)
**		22-5	6					2	4			D (1250 Vdc - 900 Vac)
**		22-15	6					5	1			D=E - Bal.=A
**		24-06	6				4		2			D (1250 Vdc - 900 Vac)
		28-22	6			3			3			D (1250 Vdc - 900 Vac)
	●	36-3	6		3			3				D (1250 Vdc - 900 Vac)
**		36-6	6		2	4						A (700 Vdc - 500 Vac)
●	●	40B6	6		5	1						A (700 Vdc - 500 Vac)
●	L	40C6	6		3			3				B (2450 Vdc - 1750 Vac)
	●	14SA7 *	7						7			I (250 Vdc - 200 Vac)
	●	16S-1 *	7						7			A (700 Vdc - 500 Vac)
		18-9	7					2	5			I (250 Vdc - 200 Vac)
	●	20-15	7					7				A (700 Vdc - 500 Vac)

● New insert

● Grommet Available

* To be used with 16S contacts size

** On request (please consult our Sales Office)

(L) Long Insert

(NS) Non Standard Shell Type

(S) Short Insert

Insulating Inserts and Grommets - List by contacts total quantity

CVS-CVB-CVBS-CVBSG-CVBR - Inserts Arrangement

	Grommet	Inserts Arrangement	N° of Contacts	Contacts Size/Current Rating								Service Rating
				4/0 225A	0 150A	4 80A	8 46A	12 23A	16 13A	18 7.5A	20 7.5A	
**		22-28	7					7				A (700 Vdc - 500 Vac)
	●	24-2	7					7				D (1250 Vdc - 900 Vac)
	●	24-10	7				7					A (700 Vdc - 500 Vac)
	●	24-27	7						7			E (1750 Vdc - 1250 Vac)
**		24A7	7					7				D (1250 Vdc - 900 Vac)
		28-10	7			2	2	3				G=D - Bal.=A
●	●	36-77	7			7						D (1250 Vdc - 900 Vac)
●	L	36A7	7			7						B (2450 Vdc - 1750 Vac)
		18-8	8					1	7			A (700 Vdc - 500 Vac)
	●	20-7	8						8			A B,H,G=D - Bal.=A
		20B8	8					4	4			A (700 Vdc - 500 Vac)
	●	22-18	8						8			A,B,F,G,H=D - Bal.=A
	●	22-23	8					8				H=D - Bal.=A
**		24-6	8					8				A,G,H=D - Bal.=A
●	L	28B8	8					8				750V (according to APTA SS-E-001-98)
		32-15	8		2			6				D (1250 Vdc - 900 Vac)
	●	40A8	8		4				4			E (1750 Vdc - 1250 Vac)
	●	40A10	8			4			4			D (1250 Vdc - 900 Vac)
●	L	40B7	8			1	7					750V (according to APTA SS-E-001-98)
**		20-16	9					2	7			A (700 Vdc - 500 Vac)
	●	20-18	9					3	6			A (700 Vdc - 500 Vac)
**		20-21	9					1	8			A (700 Vdc - 500 Vac)
**		22-17	9					1	8			A=D - Bal.=A
	●	24-11	9				3	6				A (700 Vdc - 500 Vac)
	●	28-1	9				3	6				A,J,E=D - Bal.=A
		28A9	9			4			5			A (700 Vdc - 500 Vac)
		32A9	9			3			6			A (700 Vdc - 500 Vac)
**		16A10	10						10			A (700 Vdc - 500 Vac)
	●	18-1	10						10			B,C,F,G=A - Bal.=i
	●	18-19	10						10			A (700 Vdc - 500 Vac)
	●	22A10	10						10			A (700 Vdc - 500 Vac)
**		24-21	10				1		9			D (1250 Vdc - 900 Vac)
**		28-19	10					4	6			H,M=B - A,B=D - Bal.=A
●	L	36A10	10			2	8					A (700 Vdc - 500 Vac)
●	●	40B10	10			10						A (700 Vdc - 500 Vac)
	●	20-33	11						11			A (700 Vdc - 500 Vac)
	●	24-20	11					2	9			D (1250 Vdc - 900 Vac)
●	L	40A11	11		5			6				B,N,T3,S2,R1,≠D - Bal.=A
	●	24-19	12						12			A (700 Vdc - 500 Vac)
**		28-9	12					6	6			D (1250 Vdc - 900 Vac)
	●	28-18	12						12			M=C - A,B=A - G,H,J,K,L=D - Bal.=l
	L	28-51	12					12				D (1250 Vdc - 900 Vac)
		20-11	13						13			I (250 Vdc - 200 Vac)
	●	32A13	13					13				D (1250 Vdc - 900 Vac)
**	●	32B13	13				13					A (700 Vdc - 500 Vac)

● New insert

● Grommet Available

** On request (please consult our Sales Office)

(L) Long Insert

(S) Short Insert

(NS) Non Standard Shell Type

Insulating Inserts and Grommets - List by contacts total quantity

CVS-CVB-CVBS-CVBSG-CVBR - Inserts Arrangement

	Grommet	Inserts Arrangement	N° of Contacts	Contacts Size/Current Rating								Service Rating
				4/0 225A	0 150A	4 80A	8 46A	12 23A	16 13A	18 7.5A	20 7.5A	
		● 20-27	14							14		A (700 Vdc - 500 Vac)
**	NS	● 22-19	14							14		A (700 Vdc - 500 Vac)
		28-2	14					2	12			D (1250 Vdc - 900 Vac)
**		28-20	14					10	4			A (700 Vdc - 500 Vac)
		28A14	14					14				D (1250 Vdc - 900 Vac)
●		● 36D78	14				10		4			D (1250 Vdc - 900 Vac)
		● 40A14	14			8		6				A (700 Vdc - 500 Vac)
**		28-17	15						15			M,N,P=D - R=B - Bal.=A
		● 24-5	16						16			A (700 Vdc - 500 Vac)
		● 24-7	16					2	14			A (700 Vdc - 500 Vac)
	L	24A16	16						16			D (1250 Vdc - 900 Vac)
●		● 28A16	16				2	14				A (700 Vdc - 500 Vac)
		32-68	16			4			12			A (700 Vdc - 500 Vac)
		● 20-29	17						17			A (700 Vdc - 500 Vac)
**		32A17	17				10				7	A (700 Vdc - 500 Vac)
		● 20A48	19						19			I (250 Vdc - 200 Vac)
		● 22-14	19						19			A (700 Vdc - 500 Vac)
		24-67	19					19				A (700 Vdc - 500 Vac)
**		32-76	19					19				A (700 Vdc - 500 Vac)
		● 28-16	20						20			A (700 Vdc - 500 Vac)
		● 40A20	20				2	18				D (1250 Vdc - 900 Vac)
		● 28-11	22					4	18			A (700 Vdc - 500 Vac)
		32A22	22					22				A (700 Vdc - 500 Vac)
		● 36A22	22					22				D (1250 Vdc - 900 Vac)
**		● 32-6	23			2	3	2	16			A (700 Vdc - 500 Vac)
		32-13	23					5	18			D (1250 Vdc - 900 Vac)
		22A24	24					3			21	A (700 Vdc - 500 Vac)
		● 24-28	24						24			I (250 Vdc - 200 Vac)
		● 24A25	25						25			I (250 Vdc - 200 Vac)
●		● 32A25	25					25				A (700 Vdc - 500 Vac)
●		32B25	25					25				A (700 Vdc - 500 Vac)
		● 40A25	25			1		24				A (700 Vdc - 500 Vac)
		● 28-12	26						26			A (700 Vdc - 500 Vac)
		● 24A28	28						28			I (250 Vdc - 200 Vac)
		● 40-10	29			4	9		16			A (700 Vdc - 500 Vac)
●		● 40B25	29		4				25			A (700 Vdc - 500 Vac)
		● 32-8	30					6	24			A (700 Vdc - 500 Vac)
		● 32A30	30					10	20			A (700 Vdc - 500 Vac)
	L	28A31	31				6				25	A (700 Vdc - 500 Vac)
		32-31	31						31			A (700 Vdc - 500 Vac)
**		36-9	31			1	2	14	14			A (700 Vdc - 500 Vac)
		● 40A31	31					31				D (1250 Vdc - 900 Vac)
●		32A34	34				3	4		27		1,2,3,4=A - Bal.=I
		● 28-15	35						35			A (700 Vdc - 500 Vac)
●		● 28A35	35						35			A (700 Vdc - 500 Vac)

● New insert

● Grommet Available

** On request (please consult our Sales Office)

(L) Long Insert

(NS) Non Standard Shell Type

(S) Short Insert

Insulating Inserts and Grommets - List by contacts total quantity

CVS-CVB-CVBS-CVBSG-CVBR - Inserts Arrangement

	Grommet	Inserts Arrangement	N° of Contacts	Contacts Size/Current Rating										Service Rating
				4/0	0	4	8	12	16	18	20			
				225A	150A	80A	46A	23A	13A	7.5A	7.5A			
	●	32-7	35					7	28				A,B,h,j=l - Bal.=A	
	●	36-15	35						35				M=D - Bal.=A	
	●	40A35	35					35					D (1250 Vdc - 900 Vac)	
	●	28-21	37						37				A (700 Vdc - 500 Vac)	
		40B37	37					37					A (700 Vdc - 500 Vac)	
●	●	40A38	38					38					A (700 Vdc - 500 Vac)	
●	●	36B39	39				8		31				A (700 Vdc - 500 Vac)	
	●	32-59	42				2		40				A (700 Vdc - 500 Vac)	
	●	36-7	47					7	40				A (700 Vdc - 500 Vac)	
**		36-8	47					1	46				A (700 Vdc - 500 Vac)	
	●	40-9	47				1	22	24				A (700 Vdc - 500 Vac)	
	●	40A47	47				1	22	24				A (700 Vdc - 500 Vac)	
●	●	32A48	48						48				I (250 Vdc - 200 Vac)	
	●	36-10	48						48				A (700 Vdc - 500 Vac)	
●	●	40-951	51					25	26				A (700 Vdc - 500 Vac)	
	●	32-22	54						54				A (700 Vdc - 500 Vac)	
	S	24A55	55								55		I (250 Vdc - 200 Vac)	
	●	32A55	55						55				A (700 Vdc - 500 Vac)	
●		36-66	56					4	52				A (700 Vdc - 500 Vac)	
●	●	40-62	60						60				A (700 Vdc - 500 Vac)	
**	●	40A60	60						60				A (700 Vdc - 500 Vac)	
	●	40-63	61						61				A (700 Vdc - 500 Vac)	
●	●	40A61	61		1		1		59				A (700 Vdc - 500 Vac)	
		40A62	62				2		60				A (700 Vdc - 500 Vac)	
●	●	40A65	65						65				A (700 Vdc - 500 Vac)	
●	●	40A70	70						70				A (700 Vdc - 500 Vac)	
	S	28-72	72								72		I (250 Vdc - 200 Vac)	
	●	40-56	85						85				A (700 Vdc - 500 Vac)	
●	●	40A56	85						85				A (700 Vdc - 500 Vac)	
		40A100	100							100			A (700 Vdc - 500 Vac)	
	S	32A101	101								101		I (250 Vdc - 200 Vac)	
		40A150	150							150			I (250 Vdc - 200 Vac)	
		40A201	201								201		I (250 Vdc - 200 Vac)	

GVJ - Inserts Arrangement

	Grommet	Inserts Arrangement	N. Total/ Contacts Type	Contacts Size/Current Rating										Service Rating Code
				4/0	0	4	8	12	16	18	20			
				225A	150A	80A	46A	23A	13A	7.5A	7.5A			
	●	48A4 *	4 / KT	4									D (1250 Vdc - 900 Vac)	
●	L	48-6	6 / ST	3				3					A (700 Vdc - 500 Vac)	
●		48A7 *	6 / KT	4			2						A (700 Vdc - 500 Vac)	
●	L	48A9	9 / ST	3	2			4					(PD4 OV3) 400V	
		48A58	58 / ST				1	57					A (700 Vdc - 500 Vac)	
●		48A101	101 / ST							101			A (700 Vdc - 500 Vac)	

● New insert ST Contacts for rubber inserts * Thermoplastic material (L) Long Insert (S) Short Insert
 ● Grommet Available KT Contacts for thermoplastic inserts ** On request (please consult our Sales Office) (NS) Non Standard Shell Type

Alternate Insert Positions

CVS-CVB-CVBS-CVBSG-CVBR - INSERTS ARRANGEMENT

When more than one connector with the same arrangement is mounted on the same panel, it is advisable to orientate the connector. This means to rotate the insert with respect to the polarization key so that the connector can only be mated with the correct mating half.

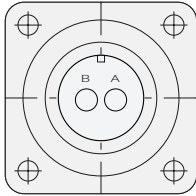

Front view mating side
Pin insert
Insert rotation

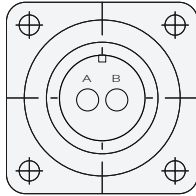

Front view mating side
Socket insert
Insert rotation

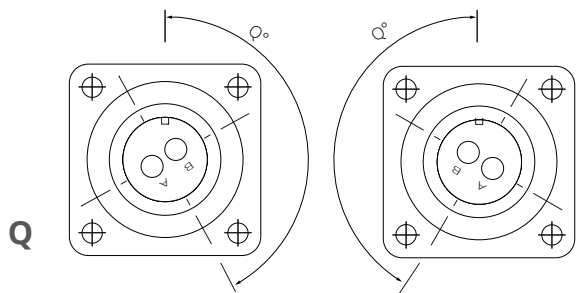
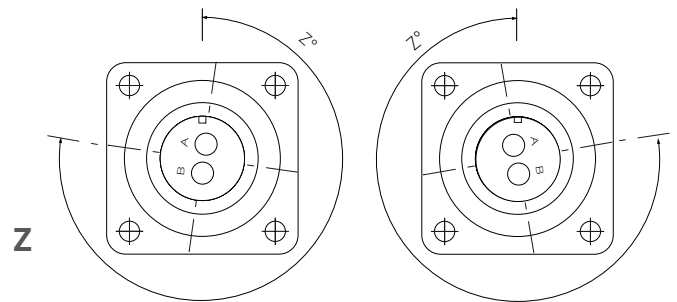
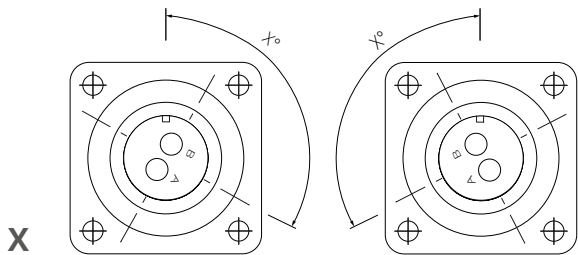
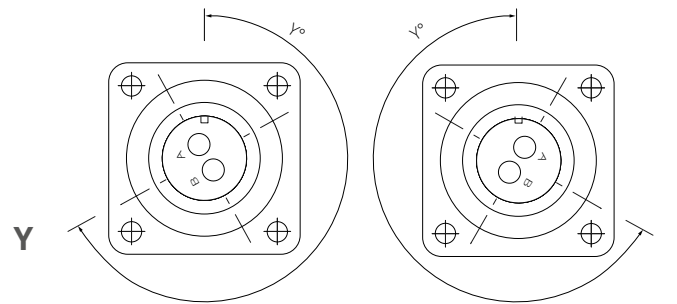
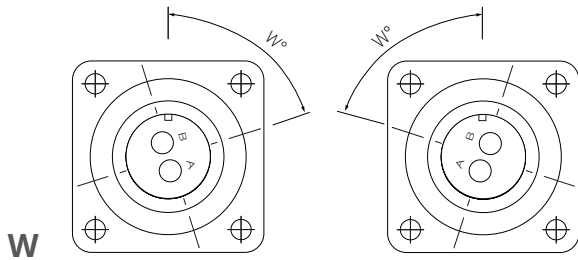

Alternate Insert Positions - List by shell size

CVS-CVB-CVBS-CVBSG-CVBR - INSERTS ARRANGEMENT

The following table lists the possible available positions for each arrangement.

Inserts Arrangement	Degrees for alternate positions				
	W	X	Y	Z	Q
10SL-3	-	-	-	-	180
10SL-4	-	-	-	-	-
14S-1	-	-	-	-	-
14S-2	-	120	240	-	-
14S-5	-	110	-	-	-
14S-6	90	-	-	-	-
14S-7	90	180	270	-	-
14SA7	-	-	-	-	-
14S-9	70	145	215	290	-
16S-1	80	-	-	280	-
16S-4	35	110	250	325	-
16S-5	70	145	215	290	-
16S-8	-	170	265	-	-
16-2	-	-	-	-	-
16-7	80	110	250	280	-
16-9	35	110	250	325	-
16-10	90	180	270	-	-
16A10	35	112	235	315	-
16-11	35	110	250	325	-
16-12	-	-	-	-	-
16A5	-	-	-	-	-
18-1	70	145	215	290	-
18-3	35	110	250	325	-
18-4	35	110	250	325	-
18-5	80	110	250	280	-
18A5	-	-	-	-	-
18-6	-	-	-	-	-
18-8	70	-	-	290	-
18-9	80	110	250	280	-
18-10	-	120	240	-	-
18-11	-	170	265	-	-
18-12	80	-	-	280	-
18-13	80	110	250	280	-
18-14	80	110	250	280	-
18-16	-	-	-	-	-
18-19	-	120	240	-	-
18-20	90	180	270	-	-
18-22	70	145	215	290	-
20-2	-	-	-	-	-
20-3	70	145	215	290	-
20-4	45	110	250	-	-

Alternate Insert Positions - List by shell size

CVS-CVB-CVBS-CVBSG-CVBR - INSERTS ARRANGEMENT

Inserts Arrangement	Degrees for alternate positions				
	W	X	Y	Z	Q
20-7	80	110	250	280	-
20-8	80	110	250	280	-
20B8	-	-	-	-	-
20-11	-	-	-	-	-
20-15	80	-	-	280	-
20-16	80	110	250	280	-
20-17	90	180	270	-	-
20-18	35	110	250	325	-
20-19	90	180	270	-	-
20-21	35	110	250	325	-
20-22	80	110	250	280	-
20-23	35	110	250	325	-
20-24	35	110	250	325	-
20-27	35	110	250	325	-
20-29	80	-	-	280	-
20-33	-	-	-	280	-
20A48	30	80	280	-	-
22-1	35	110	250	325	-
22-2	70	145	215	290	-
22-4	35	110	250	325	-
22-5	35	110	250	325	-
22-6	80	110	250	280	-
22-7	-	-	-	-	-
22-8	35	110	250	325	-
22-9	70	145	215	290	-
22-11	35	110	250	325	-
22-12	80	110	250	280	-
22-14	80	110	250	280	-
22-15	80	110	250	280	-
22-17	80	110	250	280	-
22-18	80	110	250	280	-
22-19	80	110	250	280	-
22-21	80	110	250	280	-
22-22	-	110	250	-	-
22-23	35	-	250	-	-
22-28	80	-	-	280	-
22A3	-	-	-	-	-
22A10	-	120	240	-	-
22A24	-	-	-	-	-
24-2	80	-	-	280	-
24-5	80	110	250	280	-
24-06	40	-	-	320	-

Alternate Insert Positions - List by shell size

CVS-CVB-CVBS-CVBSG-CVBR - INSERTS ARRANGEMENT

Inserts Arrangement	Degrees for alternate positions				
	W	X	Y	Z	Q
24-6	80	110	250	280	-
24-7	80	110	250	280	-
24-9	35	110	250	325	-
24-10	80	-	-	280	-
24-11	35	110	250	325	-
24-12	80	110	250	280	-
24-19	-	-	-	-	-
24-20	80	110	250	280	-
24-21	80	110	250	280	-
24-22	45	110	250	-	-
24-27	80	-	-	280	-
24-28	80	110	250	280	-
24-67	80	-	-	335	-
24A7	80	-	-	280	-
24A16	-	-	-	-	-
24A25	80	110	250	280	-
24A28	65	146	235	-	-
24A55	80	110	250	280	-
28-1	80	110	250	280	-
28-2	35	110	250	325	-
28-3	70	145	215	290	-
28-5	35	110	250	325	-
28-6	70	145	215	290	-
28-9	80	110	250	280	-
28-10	80	110	250	280	-
28-11	80	110	250	280	-
28-12	90	180	270	-	-
28-15	80	110	250	280	-
28-16	80	110	250	280	-
28-17	80	110	250	280	-
28-18	70	145	215	290	-
28-19	80	110	250	280	-
28-20	80	110	250	280	-
28-21	80	110	250	280	-
28-22	70	145	215	290	-
28-51	80	135	195	-	23
28-72	72	144	216	288	-
28A1	-	-	-	-	-
28A3	-	-	-	-	-
28A9	110	250	260	280	-
28A14	35	90	-	-	-
28A16	-	-	-	-	-



Alternate Insert Positions - List by shell size

CVS-CVB-CVBS-CVBSG-CVBR - INSERTS ARRANGEMENT

Inserts Arrangement	Degrees for alternate positions					Q
	W	X	Y	Z		
28A31	35	-	260	310	-	
28B8	25	-	-	-	-	
32-1	80	110	250	280	-	
32-2	70	145	215	290	-	
32-5	35	110	250	325	90	
32-6	80	110	250	280	-	
32-7	80	125	235	280	-	
32-8	80	125	235	280	-	
32-13	80	110	250	280	-	
32-15	35	110	250	280	80	
32-17	45	110	250	-	-	
32-22	80	110	250	280	-	
32-31	80	125	215	280	-	
32-59	36	108	252	324	-	
32-68	65	135	225	275	-	
32-76	80	110	250	280	-	
32-79	-	-	-	-	-	
32A3	22	44	76	98	-	
32A5	90	180	270	-	-	
32A9	65	135	225	275	-	
32A13	65	130	230	295	-	
32A17	-	-	-	-	-	
32A22	55	135	230	295	-	
32A25	60	120	-	-	-	
32A30	65	-	-	-	-	
32A34	-	-	-	-	-	
32A48	80	130	-	-	-	
32A55	80	110	250	280	-	
32A101	-	-	-	-	-	
32B13	-	-	-	-	-	
32B25	-	-	-	-	-	
36-3	70	145	215	290	-	
36-4	70	145	215	290	-	
36-5	45	120	240	-	-	
36-6	35	110	250	325	-	
36-7	80	110	250	280	-	
36-8	80	110	250	280	-	
36-9	80	125	235	280	-	
36-10	80	125	235	280	-	
36-15	60	125	245	305	-	
36-66	110	250	260	280	-	

Alternate Insert Positions - List by shell size

CVS-CVB-CVBS-CVBSG-CVBR - INSERTS ARRANGEMENT

Inserts Arrangement	Degrees for alternate positions				
	W	X	Y	Z	Q
36-77	-	90	-	-	-
36A7	-	-	-	-	-
36A10	45	110	250	315	-
36A22	80	110	250	280	-
36B39	-	-	-	-	-
36D78	35	106	254	325	-
40-9	65	125	225	310	-
40-10	60	125	225	310	-
40-56	72	144	216	288	150
40-62	30	130	220	290	-
40-63	80	110	250	280	-
40-951	-	-	-	-	-
40A3	70	145	215	290	-
40A4	45	110	155	-	-
40A5	33	-	-	270	-
40A8	35	110	250	325	-
40A10	60	125	225	310	-
40A11	24	48	-	-	-
40A14	80	135	195	-	-
40A20	80	110	250	280	-
40A25	50	130	260	280	-
40A31	80	110	250	280	-
40A35	70	130	230	290	-
40A38	37	74	285	322	-
40A47	65	125	225	310	-
40A60	80	110	250	280	-
40A61	-	-	-	-	-
40A62	80	130	230	280	-
40A65	-	-	-	-	-
40A70	80	110	250	280	-
40A100	30	105	230	315	-
40A150	-	-	-	-	-
40A201	-	-	-	-	-
40B3	-	-	-	-	-
40B37	30	135	-	-	-
40B6	33	-	-	270	-
40C3	-	-	-	-	-
40C6	-	-	-	-	-
48A58	80	110	250	280	-
48A101	30	105	230	315	-

Connector - Shell

COMPATIBILITY TABLE

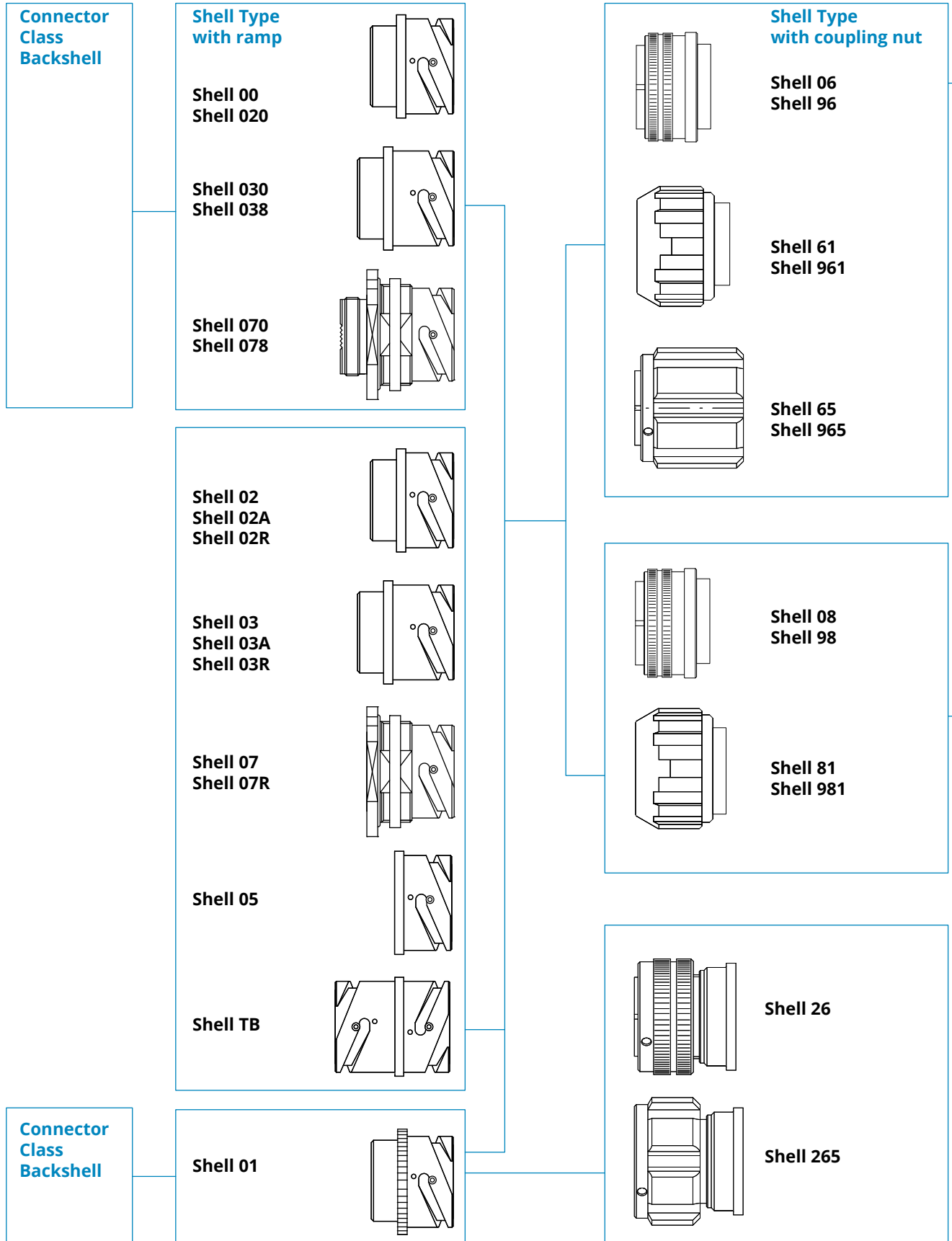

Connector - Backshell

COMPATIBILITY TABLE

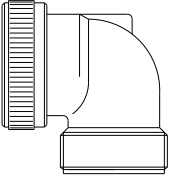
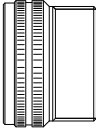
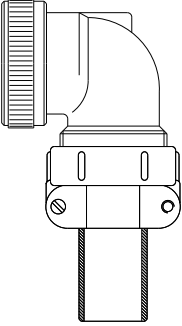
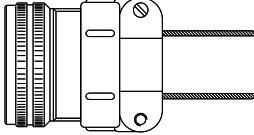
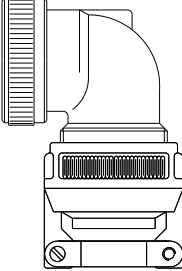
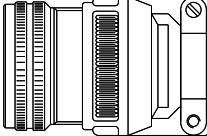
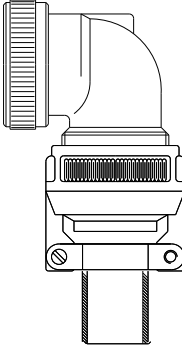
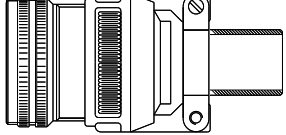
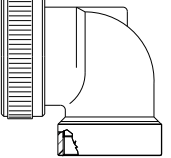
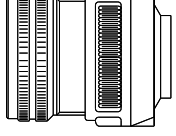
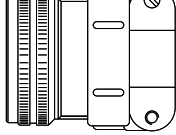
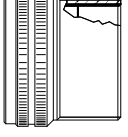
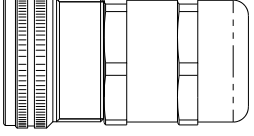
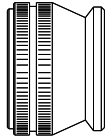
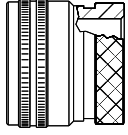
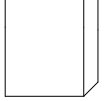
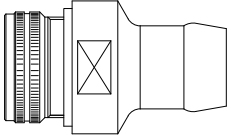
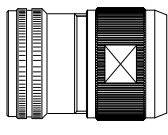
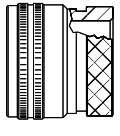
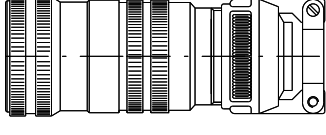
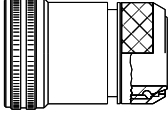
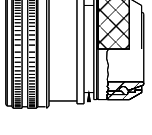
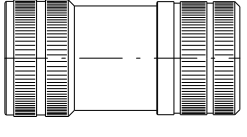
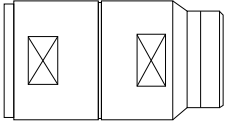
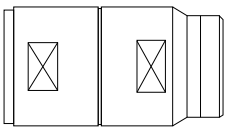
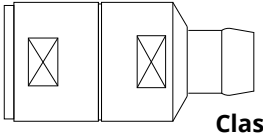
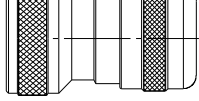
Connector Class - Elbow		Connector Class - Backshell	
	Class A DA RA		Class A DA RA Class LA LDA LRA
	Class AF F		Class AF F Class LAF LF
	Class AC ACF		Class AC ACF Class LAC LACF
	Class ACB		Class ACB
	Class DA.PG RA.PG DA..M RA..M		Class AB
			Class AS Class FA FM
			Class DA.PG RA..PG DA..M RA..M
			Class DA..PH RA..PH DA..MH RA..MH
			Class AR R
			Class AG G
			Class P
			Class DA..FS RA..FS
			Class DA..MTG RA..MTG
			Class AG2 G2
			Class ASB1 SB1
			Class AGV GV
			Class SB
			Class AMK MK AWN WN
			Class AST ST
			Class AST..M ST..M
			Class AST..FS ST..FS
			Class DA...PHM RA...PHM DA...PHM.E RA...PHM.E

Connector Class - Backshell Characteristics

Connector Class	Grommet	Watertight	Strain relief	Suggested for crimp contacts 1	Suggested for single wires	Suggested for multicore cable	Suggested for heat shrink	Suggested for shielded connection	Suggested for jacketed conduit
A			● 2		● 4	●			
DA		● 3	● 2	●	● 4	●			
RA	●	● 5 / 6	● 2	●	●	●			
LA			● 2		● 4	●			
LDA		● 3	● 2	●	● 4	●			
LRA	●	● 5 / 6	● 2	●	●	●			
AF			●		●	●			
F	●	● 5 / 7	●		●	●			
LAF			●		●	●			
LF	●	● 5 / 7	●	●		●			
AC		●	●			●			
ACF	●	●	●	●		●			
ACB		●	●			●			
LAC		●	●		●	●			
LACF	●	●	●	●	●	●			
AB		●				●			
AS			●			●			
DA..PG		● 8	● 2	●	● 9	● 9			● 9
RA..PG	●	● 7/8	● 2	●	● 9	● 9			
DA..M		● 8	● 2	●	● 9	● 9			● 9
RA..M	●	● 7/8	● 2	●	● 9	● 9			
DA..PH		●	●	●	●	●			
RA..PH	●	●	●	●	●	●			
DA..MH		●	●	●	●	●			
RA..MH	●	●	●	●	●	●			
DA..FS		●		●	●				
RA..FS	●	●		●	●				
DA..MTG		●		●	●				
RA..MTG	●	●		●	●				
DAM		●	●	●		●			
RAM	●	●	●	●		●			
R	●	● 5		●	●				
AG		●		●		●	●		
G	●	● 5		●	●	●	●		
G2	●	● 5		●	●	●	●		
ASB1		●	●	●		●		●	
SB1	●	●	●	●	●	●		●	
AGV				●		●			
GV		●		●		●		●	
SB	●	●		●		●	●	●	
AMK		●		●		●		●	
MK	●	●		●		●		●	
AWN		●	●	●		●			●
WN	●	●	●	●		●			●
FA			●			●			
FM	●		●			●			
P				●		●			
ST	●	●	●	●	●	●			

- Available
- Available, see notes

- (1) The information refers to a simple cable assembly of multicore cables with rear waterproof Cable-Clamp.
- (2) Strain relief to be ordered separately.
- (3) For multicore cables, watertightness is guaranteed only when this class is used with MS3057... C type Cable-Clamps.
- (4) Non-watertight.
- (5) For single wires, watertightness is guaranteed only if the wire diameter matches the sealing range of the grommet.
- (6) When used with multicore cable, the watertightness is guaranteed only if its single wires diameter matches the sealing range of the grommet or if a MS3057... C type Cable-Clamp is used.
- (7) When used with multicore cable, the watertightness is guaranteed only if its single wires diameter matches the sealing range of the grommet.
- (8) To guarantee watertightness, always use PG/metric adapters with IP67 protection.
- (9) When used with a suitable conduit and conduit adapter.

CVBS - Bayonet Connector with protected mating ramps - Shell - Backshell

RF CVBS 00 DA T 20-27 S X PG16 CR CD5 F7 G N



Available in several versions suitable for all applications and manufactured in different materials and finishes:

- Aluminum alloy with different types of protection finishes according to RoHS directives.

CVBS	Series Code	CVBS	Bayonet Connector with protected mating ramps
	Shell Material	-	Aluminum
00	Shell Type	xx	Flange/Plug Shell with ramp/threaded or with nut
DA	Connector Class	xx	With backshell
T	Connector Modification**	T	With plastic caps
		FF	Receptacle connector with threaded holes (to specify for 00/02/05 shell only)
		FP	Receptacle connector with through holes (to specify for 03 shell only)
		FS	Receptacle connector with countersunk holes
		V	Insert and contacts sealed (solder only)
PG16	Backshell Conduits size or internal thread	-	Without internal thread
		xx	Conduits size or internal thread
F7	Shell finish	F4	CCF - Green passivation - conductive
		F5	Electroless nickel (<i>RoHS compliance</i>)
		F7	Black epoxy varnish (<i>RoHS compliance</i>)
		F16	CCF - Black passivation - conductive (<i>RoHS compliance</i>)
		F26	Hard anodization (<i>RoHS compliance</i>)
G	Panel Gasket	-	Without gasket
		G	With waterproof panel gasket
		G2	With shielded panel gasket
N	Modification Code**	G3	With waterproof shielded panel gasket
		N	Contacts and hole plugs (Consult our sales office)
		S	Customization (Consult our sales office)

CVBS - Bayonet Connector with protected mating ramps

Front Mounting Receptacle (00) with Backshell Class (A - DA - RA)

Connector with backshell provided with an external thread suitable for MS3057...A or C type Cable-Clamps (to be ordered separately).

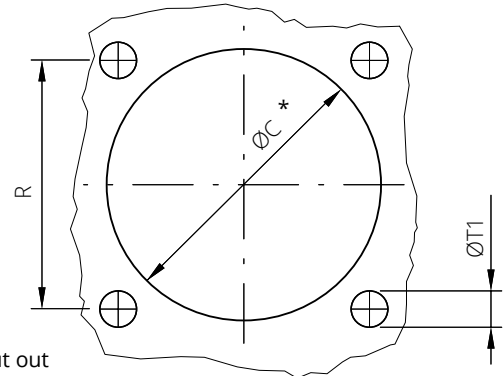

Panel cut out

* For installation with backshell mounted, consult our sales office.

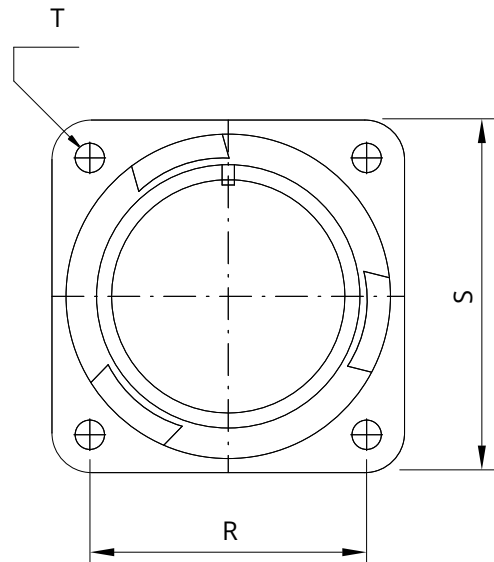
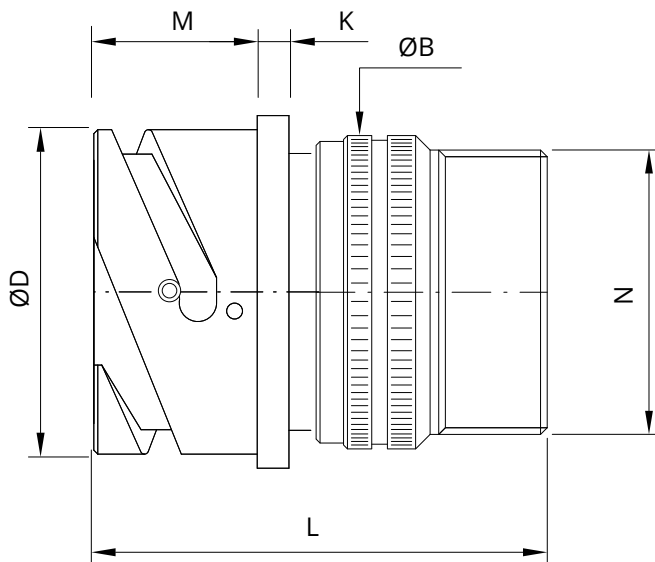

Shell size	ØD +0 -0.15	ØB ±0.2	L	M ±0.2	K ±0.2	N Backshell Thread in inches	R ±0.1	S ±0.3	ØT ±0.2	ØT1 Through holes	ØC* ±0.2
10SL	18.2	20	41	14.2	2.8	5/8"-24 UNEF	18.2	25.4	3.1	3.4	17
14S	24.6	24	42.5	14.5	3.2	3/4"-20 UNEF	23	30.2	3.1	3.4	20
16S	27.4	27	42.5	14.2	3.2	7/8"-20 UNEF	24.6	32.5	3.1	3.4	23
16	27.4	27	50	19	3.2	7/8"-20 UNEF	24.6	32.5	3.1	3.4	23
18	30.8	30	52	19	4	1"-20 UNEF	27	34.9	3.1	3.4	26.5
20	34.2	32	51	19	4	1" 3/16-18 UNEF	29.4	38.1	3.1	3.4	30
22	37.4	37	54	19.7	4	1" 3/16-18 UNEF	31.8	41	3.1	3.4	33
24	40.9	40	54	20.6	4	1" 7/16-18 UNEF	34.9	44.5	3.7	3.9	36
28	46.7	45	62	20.6	4	1" 7/16-18 UNEF	39.7	50.8	3.7	3.9	42
32	53.4	52	63	22.2	4	1" 3/4-18 UNS	44.5	57	4.4	4.5	48.5
36	59.6	58	63	22.2	4	2"-18 UNS	49.2	63.5	4.4	4.5	55
40	65.5	63.2	63	22.2	4	2"1/4-16 UN	55.6	69.8	4.4	4.5	61

Dimensions in mm

Dimension "L" can be different from the value indicated according to backshells accessories, wires size and some special insert configurations.

CVBS - Bayonet Connector with protected mating ramps



Series Shell Shell Connector
Code Material Type Class

Shell
finish

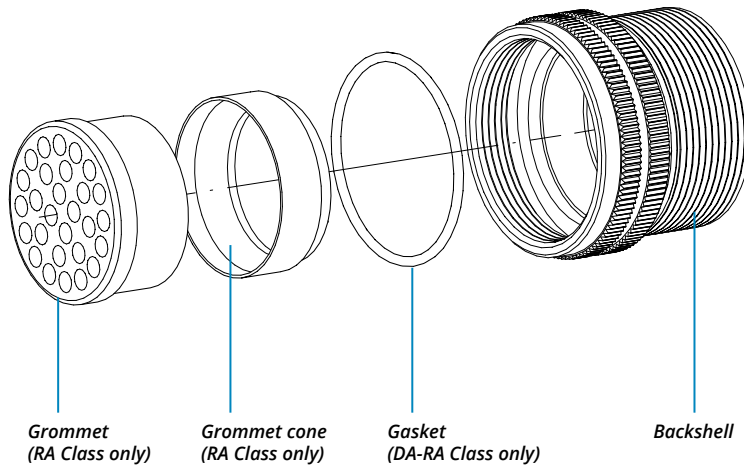

RF	Insulating material	-	Chloroprene rubber
		V	Fluoride rubber
		S	Silicone rubber
		RF	Fire resistant rubber
CVBS	Series Code	CVBS	Bayonet Connector with protected mating ramps
	Shell Material	-	Aluminum
00	Shell Type	00	Front mounting Receptacle
DA	Connector Class	A	non watertight
		DA	with waterproof O-ring (IP67***)
		RA	with waterproof O-ring and grommet (IP67***)
T	Connector Modification**	T	With plastic caps
		FF	Receptacle connector with threaded holes
		-	Receptacle connector with through holes
		FS	Receptacle connector with countersunk holes
20-27	Insert Arrangement		Size - Type

S	Contact Gender	S	Socket contacts
		P	Pin contacts
X	Polarization Code**		Alternate Positions
CR	Contact Termination	-	Solder contacts
		CR	Crimp contacts
		LC	Less contacts
CD5	Contact Plating	-	Silver plating
		CD5	Gold plating
F7	Shell finish	F5	Electroless nickel (*)
		F7	Black epoxy varnish (*)
		F16	CCF - Black passivation (*) - conductive
		F26	hard anodization (*)
G	Panel Gasket	-	Without gasket
		G	With waterproof panel gasket
		G2	With shielded panel gasket
		G3	With waterproof shielded panel gasket
N	Modification Code**	N	Consult our sales office
		S	

*** Protection degree: IP 67 (only in the mating area with mated connectors) according to EN 60529 (*) RoHS compliance (**) If required

P/N Sample: RF CVBS 00DAT 20-27SX CR CD5 F7 G N

CVBS - Bayonet Connector with protected mating ramps

Front Mounting Receptacle (00) with Backshell Class (LA - LDA - LRA)

Connector with long backshell provided with an external thread suitable for MS3057...A or C type Cable-Clamps (to be ordered separately).

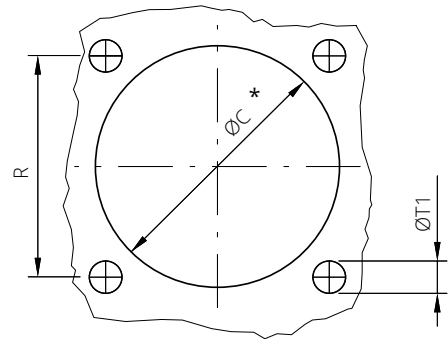

Panel cut out

* For installation with backshell mounted, consult our sales office.

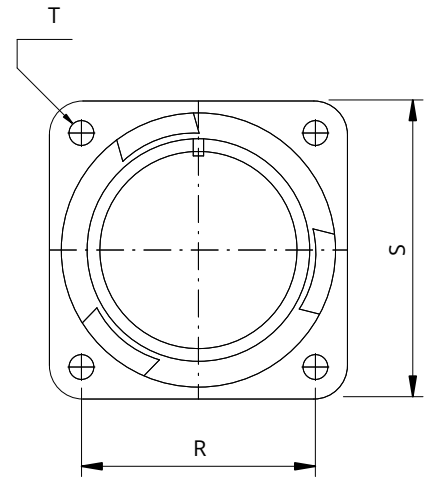
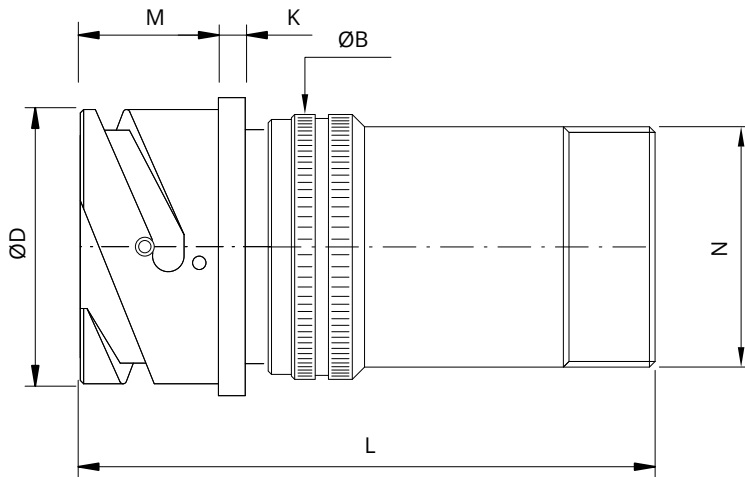

Shell size	ØD +0 -0.15	ØB ±0.2	L	M ±0.2	K ±0.2	N Backshell Thread in inches	R ±0.1	S ±0.3	ØT ±0.2	ØT1 Through holes	ØC* ±0.2
10SL	18.2	20	67	14.2	2.8	5/8"-24 UNEF	18.2	25.4	3.1	3.4	17
14S	24.6	24	67	14.5	3.2	3/4"-20 UNEF	23	30.2	3.1	3.4	20
16S	27.4	27	67	14.2	3.2	7/8"-20 UNEF	24.6	32.5	3.1	3.4	23
16	27.4	27	77	19	3.2	7/8"-20 UNEF	24.6	32.5	3.1	3.4	23
18	30.8	30	77.5	19	4	1"-20 UNEF	27	34.9	3.1	3.4	26.5
20	34.2	32	78	19	4	1" 3/16-18 UNEF	29.4	38.1	3.1	3.4	30
22	37.4	37	79	19.7	4	1" 3/16-18 UNEF	31.8	41	3.1	3.4	33
24	40.9	40	81	20.6	4	1" 7/16-18 UNEF	34.9	44.5	3.7	3.9	36
28	46.7	45	81	20.6	4	1" 7/16-18 UNEF	39.7	50.8	3.7	3.9	42
32	53.4	52	95.5	22.2	4	1" 3/4-18 UNS	44.5	57	4.4	4.5	48.5
36	59.6	58	95.5	22.2	4	2"-18 UNS	49.2	63.5	4.4	4.5	55
40	65.5	63.2	95.5	22.2	4	2" 1/4-16 UN	55.6	69.8	4.4	4.5	61

Dimensions in mm

Dimension "L" can be different from the value indicated according to backshells accessories, wires size and some special insert configurations.

CVBS - Bayonet Connector with protected mating ramps



Series Code: CVBS
 Shell Material: (empty)
 Shell Type: 00
 Connector Class: LDA

Shell finish: F7

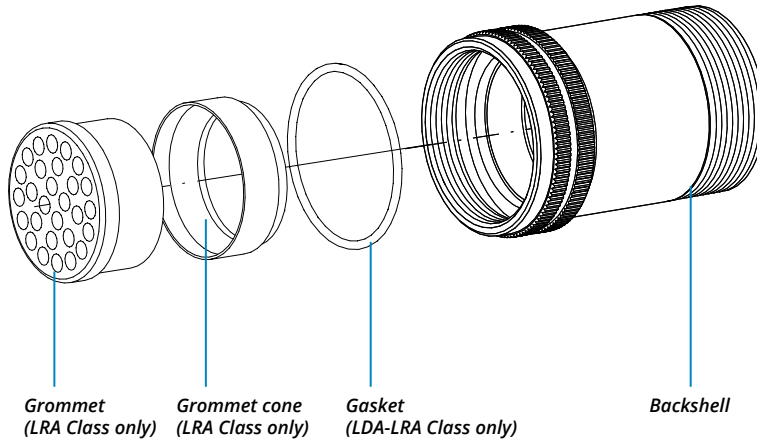

RF	Insulating material	-	Chloroprene rubber
		V	Fluoride rubber
		S	Silicone rubber
		RF	Fire resistant rubber
CVBS	Series Code	CVBS	Bayonet Connector with protected mating ramps
(empty)	Shell Material	-	Aluminum
00	Shell Type	00	Front mounting Receptacle
LDA	Connector Class	LA	non watertight
		LDA	with waterproof O-ring (IP67***)
		LRA	with waterproof O-ring and grommet (IP67***)
T	Connector Modification**	T	With plastic caps
		FF	Receptacle connector with threaded holes
		-	Receptacle connector with through holes
		FS	Receptacle connector with countersunk holes
20-27	Insert Arrangement		Size - Type

S	Contact Gender	S	Socket contacts
		P	Pin contacts
X	Polarization Code**		Alternate Positions
CR	Contact Termination	-	Solder contacts
		CR	Crimp contacts
		LC	Less contacts
CD5	Contact Plating	-	Silver plating
		CD5	Gold plating
F7	Shell finish	F5	Electroless nickel (*)
		F7	Black epoxy varnish (*)
		F16	CCF - Black passivation (*) - conductive
		F26	hard anodization (*)
G	Panel Gasket	-	Without gasket
		G	With waterproof panel gasket
		G2	With shielded panel gasket
		G3	With waterproof shielded panel gasket
N	Modification Code**	N	Consult our sales office
		S	

*** Protection degree: IP 67 (only in the mating area with mated connectors) according to EN 60529 (*) RoHS compliance (**) If required

P/N Sample: RF CVBS 00LDAT 20-27SX CR CD5 F7 G N

CVBS - Bayonet Connector with protected mating ramps

Front Mounting Receptacle (00) with Backshell Class (AF - F)

Connector provided with backshell, MS3057...A type Cable-Clamp and bushing MS3420... (for single wire)

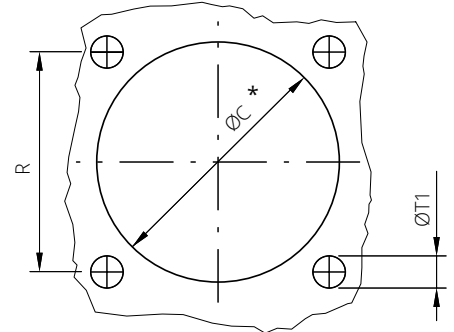

Panel cut out

* For installation with backshell mounted, consult our sales office.

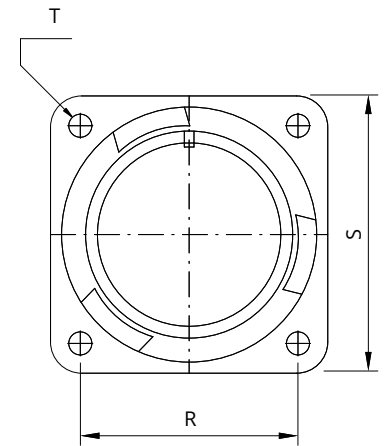
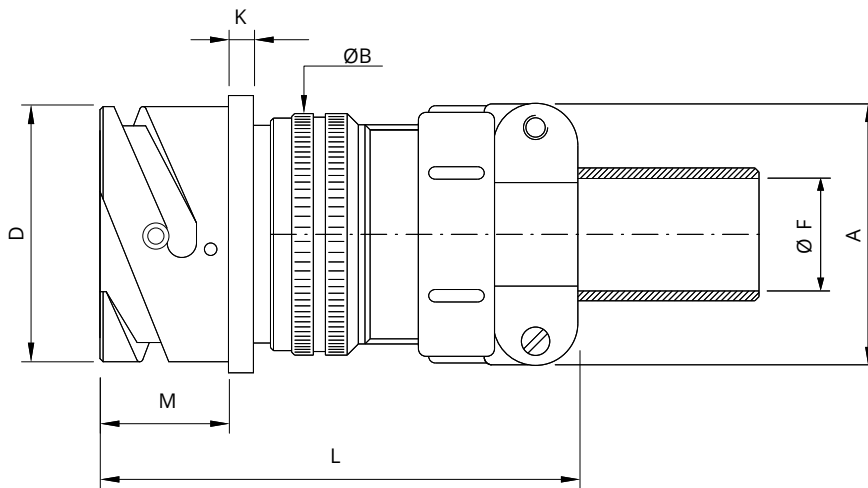

Shell size	ØD +0 -0.15	ØB ±0.2	L	M ±0.2	K ±0.2	A max	ØF cable max dimension	R ±0.1	S ±0.3	ØT ±0.2	ØT1 Through holes	ØC* ±0.2
10SL	18.2	20	51	14.2	2.8	22.5	5.6	18.2	25.4	3.1	3.4	17
14S	24.6	24	54.5	14.5	3.2	28	7.9	23	30.2	3.1	3.4	20
16S	27.4	27	56	14.2	3.2	30	11	24.6	32.5	3.1	3.4	23
16	27.4	27	63.5	19	3.2	30	11	24.6	32.5	3.1	3.4	23
18	30.8	30	66.5	19	4	31.7	14.2	27	34.9	3.1	3.4	26.5
20	34.2	32	66.5	19	4	37.5	15.8	29.4	38.1	3.1	3.4	30
22	37.4	37	69.5	19.7	4	37.5	15.8	31.8	41	3.1	3.4	33
24	40.9	40	69.5	20.6	4	43.5	19	34.9	44.5	3.7	3.9	36
28	46.7	45	77.5	20.6	4	43.5	19	39.7	50.8	3.7	3.9	42
32	53.4	52	78.5	22.2	4	51.7	23.8	44.5	57	4.4	4.5	48.5
36	59.6	58	78.5	22.2	4	58.5	31.7	49.2	63.5	4.4	4.5	55
40	65.5	63.2	92	22.2	4	68.5	34.9	55.6	69.8	4.4	4.5	61

Dimensions in mm

Dimension "L" can be different from the value indicated according to backshells accessories, wires size and some special insert configurations.

CVBS - Bayonet Connector with protected mating ramps

RF	CVBS		00	AF	T	20-27	S	X		CR	CD5	F7	G	N
Series Code	Shell Material	Shell Type	Connector Class	Connector Class								Shell finish		

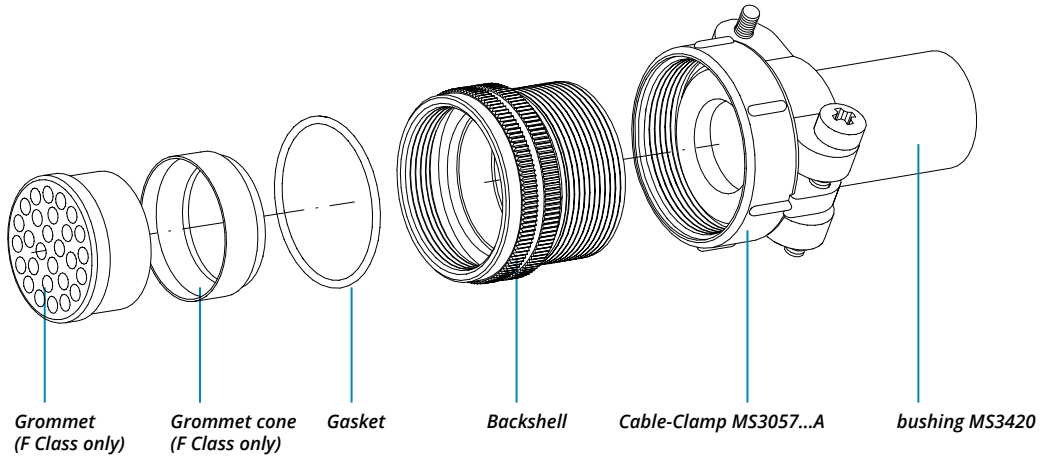

RF	Insulating material	-	Chloroprene rubber
		V	Fluoride rubber
		S	Silicone rubber
		RF	Fire resistant rubber
CVBS	Series Code	CVBS	Bayonet Connector with protected mating ramps
	Shell Material	-	Aluminum
00	Shell Type	00	Front mounting Receptacle
AF	Connector Class	F	with waterproof O-ring and grommet (IP54)
		AF	with waterproof O-ring (IP54)
T	Connector Modification**	T	With plastic caps
		FF	Receptacle connector with threaded holes
		-	Receptacle connector with through holes
		FS	Receptacle connector with countersunk holes
20-27	Insert Arrangement		Size - Type

S	Contact Gender	S	Socket contacts
		P	Pin contacts
X	Polarization Code**		Alternate Positions
CR	Contact Termination	-	Solder contacts
		CR	Crimp contacts
		LC	Less contacts
CD5	Contact Plating	-	Silver plating
		CD5	Gold plating
F7	Shell finish	F5	Electroless nickel (*)
		F7	Black epoxy varnish (*)
		F16	CCF - Black passivation (*) - conductive
		F26	hard anodization (*)
G	Panel Gasket	-	Without gasket
		G	With waterproof panel gasket
		G2	With shielded panel gasket
G3			With waterproof shielded panel gasket
N	Modification Code**	N	
		S	Consult our sales office

P/N Sample: RF CVBS 00AFT 20-27SX CR CD5 F7 G N

(*) RoHS compliance

(**) If required

CVBS - Bayonet Connector with protected mating ramps

Front Mounting Receptacle (00) with Backshell Class (LAF - LF)

Connector provided with long backshell, MS3057...A type Cable-Clamp and bushing MS3420... (for single wire)

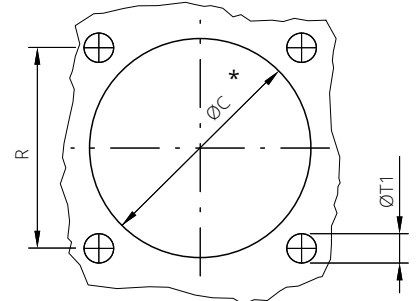

Panel cut out

* For installation with backshell mounted, consult our sales office.

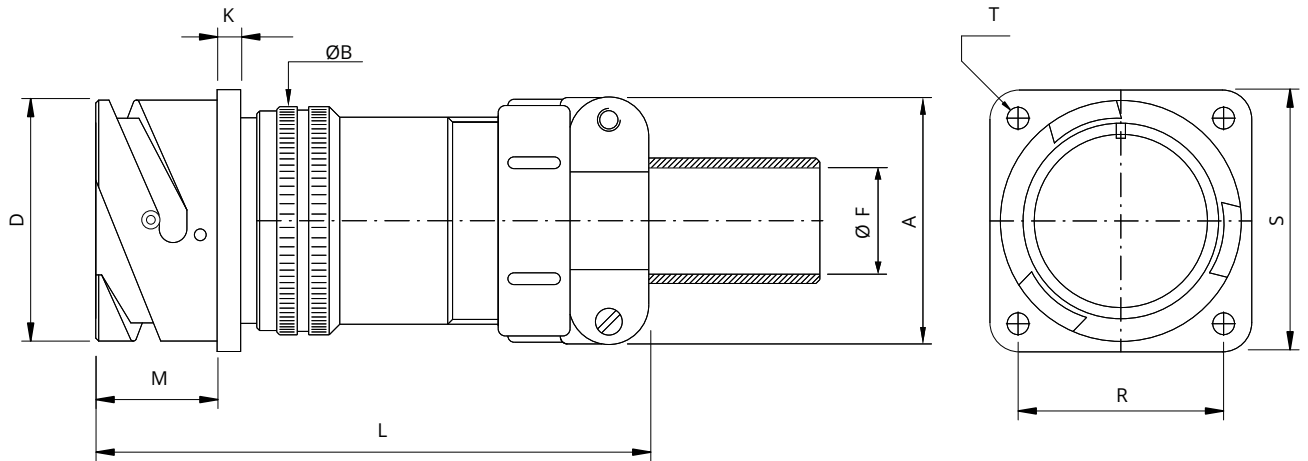

Shell size	ØD +0 -0.15	ØB ±0.2	L	M ±0.2	K ±0.2	A max	ØF cable max dimension	R ±0.1	S ±0.3	ØT ±0.2	ØT1 Through holes	ØC* ±0.2
10SL	18.2	20	77	14.2	2.8	22.5	5.6	18.2	25.4	3.1	3.4	17
14S	24.6	24	79	14.5	3.2	28	7.9	23	30.2	3.1	3.4	20
16S	27.4	27	80.5	14.2	3.2	30	11	24.6	32.5	3.1	3.4	23
16	27.4	27	90.5	19	3.2	30	11	24.6	32.5	3.1	3.4	23
18	30.8	30	93	19	4	31.7	14.2	27	34.9	3.1	3.4	26.5
20	34.2	32	93.5	19	4	37.5	15.8	29.4	38.1	3.1	3.4	30
22	37.4	37	94.5	19.7	4	37.5	15.8	31.8	41	3.1	3.4	33
24	40.9	40	96.5	20.6	4	43.5	19	34.9	44.5	3.7	3.9	36
28	46.7	45	96.5	20.6	4	43.5	19	39.7	50.8	3.7	3.9	42
32	53.4	52	111	22.2	4	51.7	23.8	44.5	57	4.4	4.5	48.5
36	59.6	58	111	22.2	4	58.5	31.7	49.2	63.5	4.4	4.5	55
40	65.5	63.2	124.5	22.2	4	68.5	34.9	55.6	69.8	4.4	4.5	61

Dimensions in mm

Dimension "L" can be different from the value indicated according to backshells accessories, wires size and some special insert configurations.

CVBS - Bayonet Connector with protected mating ramps



Series Code **Shell Material** **Shell Type** **Connector Class**

Shell finish

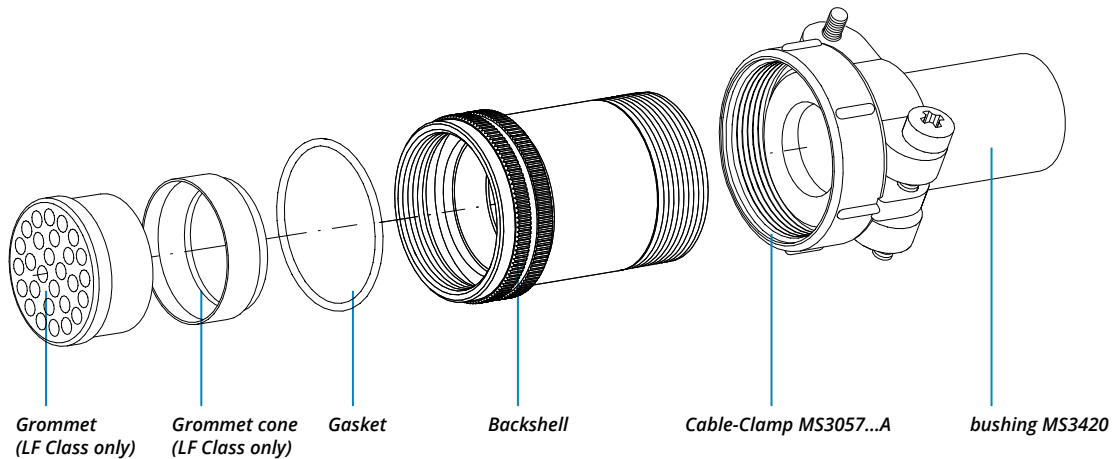

RF	Insulating material	-	Chloroprene rubber
		V	Fluoride rubber
		S	Silicone rubber
		RF	Fire resistant rubber
CVBS	Series Code	CVBS	Bayonet Connector with protected mating ramps
[]	Shell Material	-	Aluminum
00	Shell Type	00	Front mounting Receptacle
LAF	Connector Class	LF	with waterproof O-ring and grommet (IP54)
		LAF	with waterproof O-ring (IP54)
T	Connector Modification**	T	With plastic caps
		FF	Receptacle connector with threaded holes
		-	Receptacle connector with through holes
		FS	Receptacle connector with countersunk holes
20-27	Insert Arrangement		Size - Type

S	Contact Gender	S	Socket contacts
		P	Pin contacts
X	Polarization Code**		Alternate Positions
CR	Contact Termination	-	Solder contacts
		CR	Crimp contacts
		LC	Less contacts
CD5	Contact Plating	-	Silver plating
		CD5	Gold plating
F7	Shell finish	F5	Electroless nickel (*)
		F7	Black epoxy varnish (*)
		F16	CCF - Black passivation (*) - conductive
		F26	hard anodization (*)
G	Panel Gasket	-	Without gasket
		G	With waterproof panel gasket
		G2	With shielded panel gasket
		G3	With waterproof shielded panel gasket
N	Modification Code**	N	Consult our sales office
		S	

P/N Sample: RF CVBS 00LAFT 20-27SX CR CD5 F7 G N

(*) RoHS compliance

(**) If required

CVBS - Bayonet Connector with protected mating ramps

Front Mounting Receptacle (00) with Backshell Class (AC - ACF)

Connector provided with backshell, MS3057...C type Cable-Clamp (for jacketed cable)

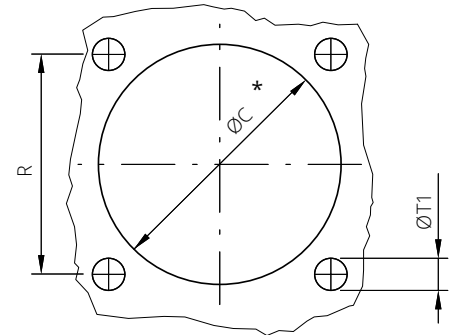

Panel cut out

* For installation with backshell mounted, consult our sales office.

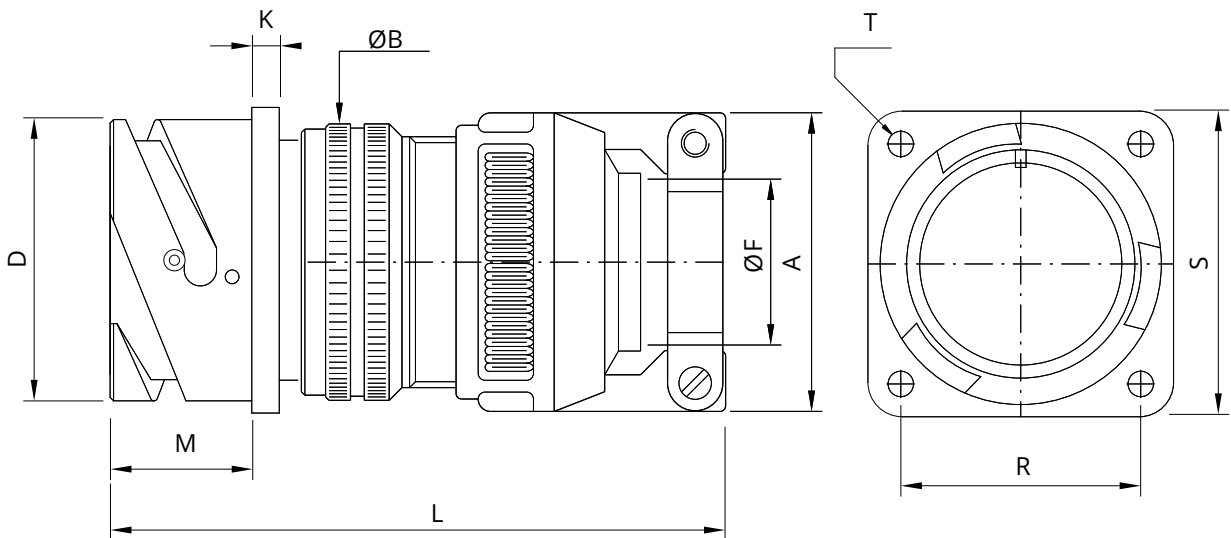

Shell size	ØD +0 -0.15	ØB ±0.2	L	K ±0.2	M ±0.2	A ±0.2	ØF cable dimension	R ±0.1	S ±0.3	ØT ±0.2	ØT1 Through holes	ØC* ±0.2
------------	-------------------	------------	---	-----------	-----------	-----------	--------------------------	-----------	-----------	------------	-------------------------	-------------

							Min	Max				
10SL	18.2	20	65	2.8	14.2	23	2.4	7.9	18.2	25.4	3.1	3.4
14S	24.6	24	66.5	3.2	14.5	26	5.8	11.2	23	30.2	3.1	3.4
16S	27.4	27	67.5	3.2	14.2	28.5	8	13.5	24.6	32.5	3.1	3.4
16	27.4	27	75	3.2	19	28.5	8	13.5	24.6	32.5	3.1	3.4
18	30.8	30	78.5	4	19	32	9.6	15.9	27	34.9	3.1	3.4
20	34.2	32	77.5	4	19	37.5	11.3	19	29.4	38.1	3.1	3.4
22	37.4	37	80.5	4	19.7	37.5	11.3	19	31.8	41	3.1	3.4
24	40.9	40	87.5	4	20.6	43.5	15.5	23.8	34.9	44.5	3.7	3.9
28	46.7	45	95.5	4	20.6	43.5	15.5	23.8	39.7	50.8	3.7	3.9
32	53.4	52	101	4	22.2	54	23.4	31.8	44.5	57	4.4	4.5
36	59.6	58	105.5	4	22.2	58	25.4	35	49.2	63.5	4.4	4.5
40	65.5	63.2	107	4	22.2	63.5	30	41.3	55.6	69.8	4.4	4.5

Dimensions in mm

Dimension "L" can be different from the value indicated according to backshells accessories, wires size and some special insert configurations.

CVBS - Bayonet Connector with protected mating ramps



Series Shell Shell Connector
Code Material Type Class

Shell
finish

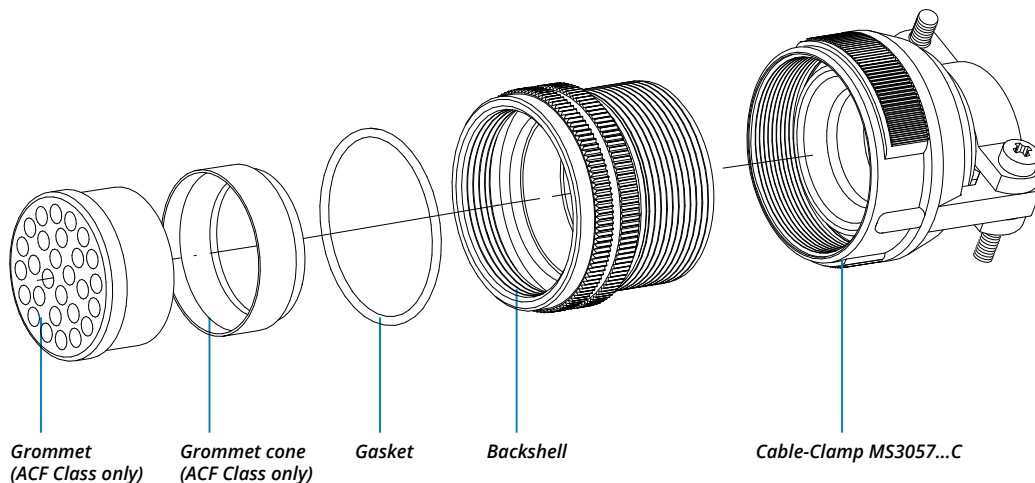

RF	Insulating material	-	Chloroprene rubber
		V	Fluoride rubber
		S	Silicone rubber
		RF	Fire resistant rubber
CVBS	Series Code	CVBS	Bayonet Connector with protected mating ramps
[]	Shell Material	-	Aluminum
00	Shell Type	00	Front mounting Receptacle
AC	Connector Class	ACF	with waterproof O-ring and grommet (IP67)
		AC	with waterproof O-ring (IP67)
T	Connector Modification**	T	With plastic caps
		FF	Receptacle connector with threaded holes
		-	Receptacle connector with through holes
20-27	Insert Arrangement	FS	Receptacle connector with countersunk holes
			Size - Type

S	Contact Gender	S	Socket contacts
		P	Pin contacts
X	Polarization Code**		Alternate Positions
CR	Contact Termination	-	Solder contacts
		CR	Crimp contacts
		LC	Less contacts
CD5	Contact Plating	-	Silver plating
		CD5	Gold plating
F7	Shell finish	F5	Electroless nickel (*)
		F7	Black epoxy varnish (*)
		F16	CCF - Black passivation (*) - conductive
		F26	hard anodization (*)
G	Panel Gasket	-	Without gasket
		G	With waterproof panel gasket
		G2	With shielded panel gasket
N	Modification Code**	G3	With waterproof shielded panel gasket
		N	
		S	Consult our sales office

P/N Sample: RF CVBS 00ACT 20-27SX CR CD5 F7 G N

(*) RoHS compliance

(**) If required

CVBS - Bayonet Connector with protected mating ramps

Front Mounting Receptacle (00) with Backshell Class (ACB)

Connector provided with backshell, MS3057...C type Cable-Clamp and bushing MS 3420A (for jacketed cable)

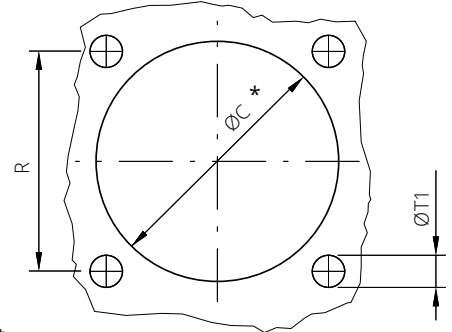

Panel cut out

* For installation with backshell mounted, consult our sales office.

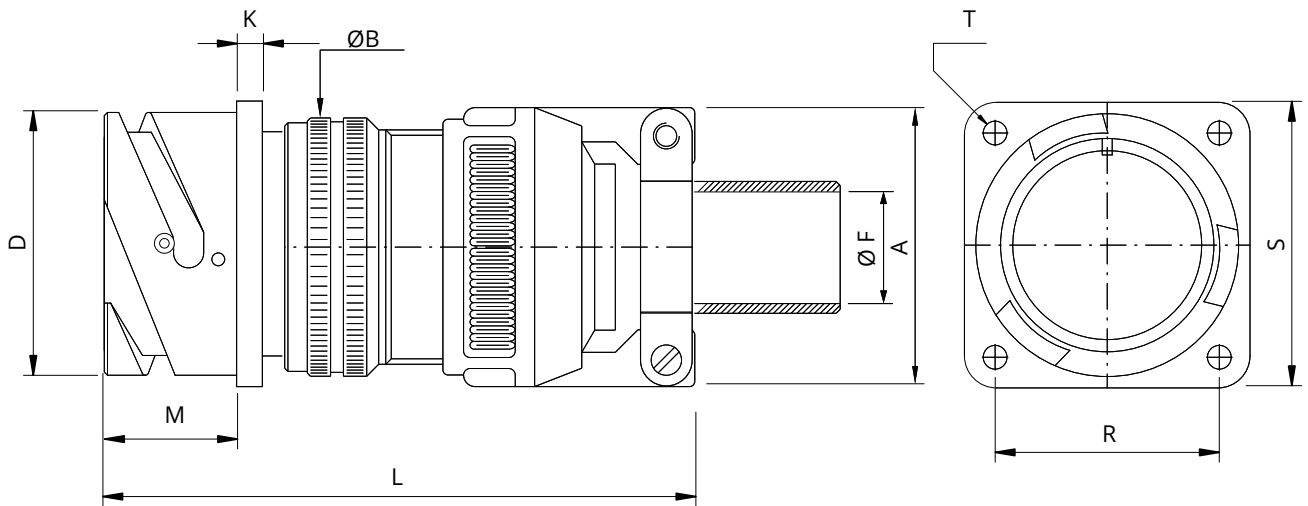

Shell size	ØD +0 -0.15	ØB ±0.2	L	K ±0.2	M ±0.2	A ±0.2	ØF max cable size	R ±0.1	S ±0.3	ØT ±0.2	ØT1 Through holes	ØC* ±0.2
10SL	18.2	20	65	2.8	14.2	23	5.6	18.2	25.4	3.1	3.4	17
14S	24.6	24	66.5	3.2	14.5	26	7.9	23	30.2	3.1	3.4	20
16S	27.4	27	67.5	3.2	14.2	28.5	11.1	24.6	32.5	3.1	3.4	23
16	27.4	27	75	3.2	19	28.5	11.1	24.6	32.5	3.1	3.4	23
18	30.8	30	78.5	4	19	32	11.1	27	34.9	3.1	3.4	26.5
20	34.2	32	77.5	4	19	37.5	13.7	29.4	38.1	3.1	3.4	30
22	37.4	37	80.5	4	19.7	37.5	13.7	31.8	41	3.1	3.4	33
24	40.9	40	87.5	4	20.6	43.5	19	34.9	44.5	3.7	3.9	36
28	46.7	45	95.5	4	20.6	43.5	19	39.7	50.8	3.7	3.9	42
32	53.4	52	101	4	22.2	54	23.8	44.5	57	4.4	4.5	48.5
36	59.6	58	105.5	4	22.2	58	28.5	49.2	63.5	4.4	4.5	55
40	65.5	63.2	107	4	22.2	63.5	31.8	55.6	69.8	4.4	4.5	61

Dimensions in mm

Dimension "L" can be different from the value indicated according to backshells accessories, wires size and some special insert configurations.

CVBS - Bayonet Connector with protected mating ramps

RF	CVBS		00	ACB	T	20-27	S	X		CR	CD5	F7	G	N
Series Code	Shell Material	Shell Type	Connector Class									Shell finish		

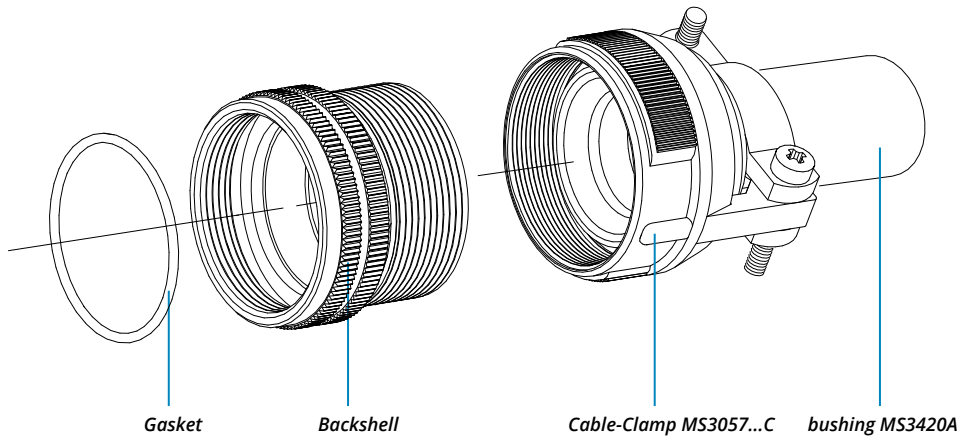

RF	Insulating material	-	Chloroprene rubber
		V	Fluoride rubber
		S	Silicone rubber
		RF	Fire resistant rubber
CVBS	Series Code	CVBS	Bayonet Connector with protected mating ramps
	Shell Material	-	Aluminum
00	Shell Type	00	Front mounting Receptacle
ACB	Connector Class	ACB	with waterproof O-ring
T	Connector Modification**	T	With plastic caps
		FF	Receptacle connector with threaded holes
		-	Receptacle connector with through holes
		FS	Receptacle connector with countersunk holes
20-27	Insert Arrangement		Size - Type

S	Contact Gender	S	Socket contacts
		P	Pin contacts
X	Polarization Code**		Alternate Positions
CR	Contact Termination	-	Solder contacts
		CR	Crimp contacts
		LC	Less contacts
CD5	Contact Plating	-	Silver plating
		CD5	Gold plating
F7	Shell finish	F5	Electroless nickel (*)
		F7	Black epoxy varnish (*)
		F16	CCF - Black passivation (*) - conductive
		F26	hard anodization (*)
G	Panel Gasket	-	Without gasket
		G	With waterproof panel gasket
		G2	With shielded panel gasket
		G3	With waterproof shielded panel gasket
N	Modification Code**	N	
		S	Consult our sales office

P/N Sample: RF CVBS 00ACBT 20-27SX CR CD5 F7 G N

(*) RoHS compliance

(**) If required

CVBS - Bayonet Connector with protected mating ramps

Front Mounting Receptacle (00) with Backshell Class (LAC - LACF)

Connector provided with long backshell, MS3057...C type Cable-Clamp (for jacketed cable)

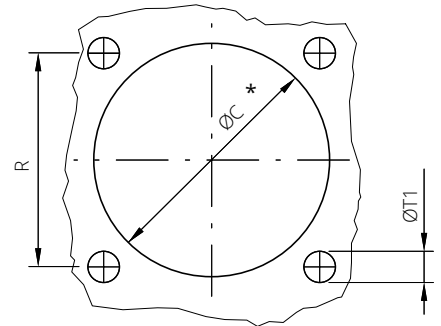

Panel cut out

* For installation with backshell mounted, consult our sales office.

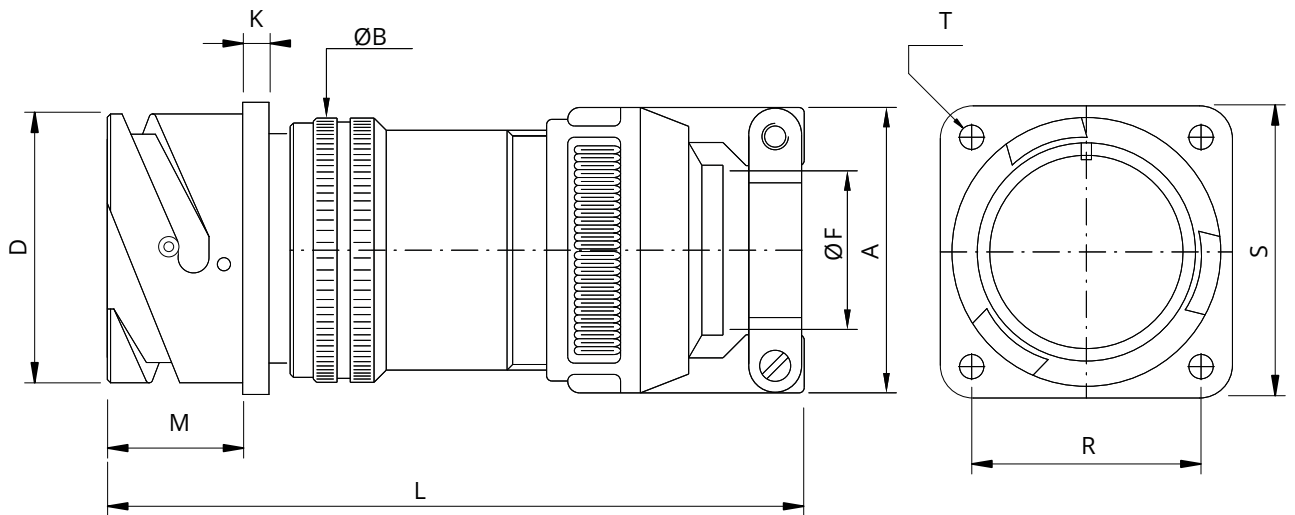

Shell size	ØD +0 -0.15	ØB ±0.2	K ±0.2	L	M ±0.2	A ±0.2	ØF cable dimension		R ±0.1	S ±0.3	ØT ±0.2	ØT1 Through holes	ØC* ±0.2
							Min	Max					
10SL	18.2	20	2.8	91	14.2	23	2.4	7.9	18.2	25.4	3.1	3.4	17
14S	24.6	24	3.2	91	14.5	26	5.8	11.2	23	30.2	3.1	3.4	20
16S	27.4	27	3.2	92	14.2	28.5	8	13.5	24.6	32.5	3.1	3.4	23
16	27.4	27	3.2	102	19	28.5	8	13.5	24.6	32.5	3.1	3.4	23
18	30.8	30	4	105	19	32	9.6	15.9	27	34.9	3.1	3.4	26.5
20	34.2	32	4	105	19	37.5	11.3	19	29.4	38.1	3.1	3.4	30
22	37.4	37	4	106	19.7	37.5	11.3	19	31.8	41	3.1	3.4	33
24	40.9	40	4	114.5	20.6	43.5	15.5	23.8	34.9	44.5	3.7	3.9	36
28	46.7	45	4	114.5	20.6	43.5	15.5	23.8	39.7	50.8	3.7	3.9	42
32	53.4	52	4	133.5	22.2	54	23.4	31.8	44.5	57	4.4	4.5	48.5
36	59.6	58	4	138	22.2	58	25.4	35	49.2	63.5	4.4	4.5	55
40	65.5	63.2	4	139.5	22.2	63.5	30	41.3	55.6	69.8	4.4	4.5	61

Dimensions in mm

Dimension "L" can be different from the value indicated according to backshells accessories, wires size and some special insert configurations.

CVBS - Bayonet Connector with protected mating ramps

RF	CVBS		00	LAC	T	20-27	S	X		CR	CD5	F7	G	N
Series Code	Shell Material	Shell Type	Connector Class											Shell finish

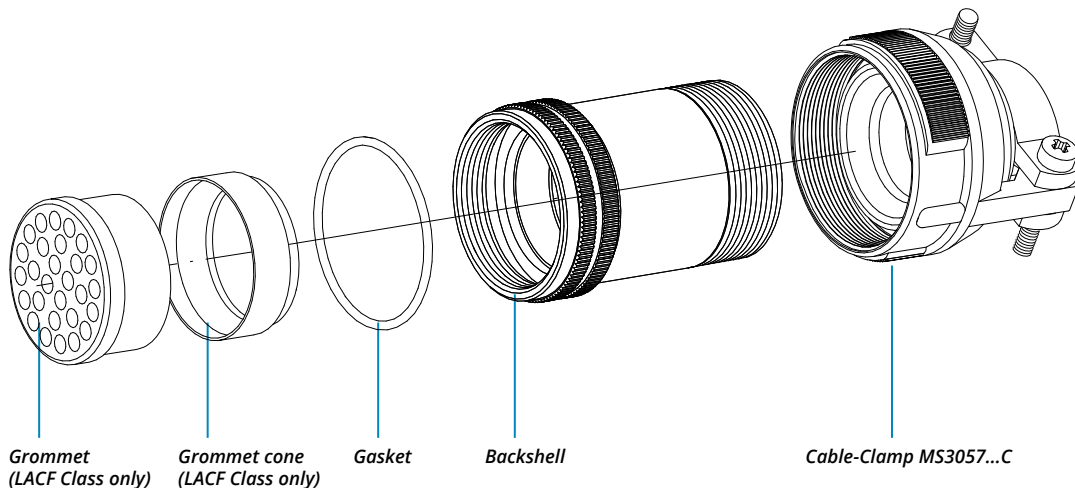

RF	Insulating material	-	Chloroprene rubber
		V	Fluoride rubber
		S	Silicone rubber
		RF	Fire resistant rubber
CVBS	Series Code	CVBS	Bayonet Connector with protected mating ramps
	Shell Material	-	Aluminum
00	Shell Type	00	Front mounting Receptacle
LAC	Connector Class	LACF	with waterproof O-ring and grommet (IP67)
		LAC	with waterproof O-ring (IP67)
	Connector Modification**	T	With plastic caps
		FF	Receptacle connector with threaded holes
		-	Receptacle connector with through holes
		FS	Receptacle connector with countersunk holes
20-27	Insert Arrangement		Size - Type

S	Contact Gender	S	Socket contacts
		P	Pin contacts
X	Polarization Code**		Alternate Positions
CR	Contact Termination	-	Solder contacts
		CR	Crimp contacts
		LC	Less contacts
CD5	Contact Plating	-	Silver plating
		CD5	Gold plating
F7	Shell finish	F5	Electroless nickel (*)
		F7	Black epoxy varnish (*)
		F16	CCF - Black passivation (*) - conductive
		F26	hard anodization (*)
G	Panel Gasket	-	Without gasket
		G	With waterproof panel gasket
		G2	With shielded panel gasket
		G3	With waterproof shielded panel gasket
N	Modification Code**	N	Consult our sales office
		S	

P/N Sample: RF CVBS 00LACT 20-27SX CR CD5 F7 G N

(*) RoHS compliance

(**) If required

CVBS - Bayonet Connector with protected mating ramps

Front Mounting Receptacle (00) with Backshell Class (AB)

Connector provided with backshell, MS3057...B type Cable-Clamp (for jacketed cable)

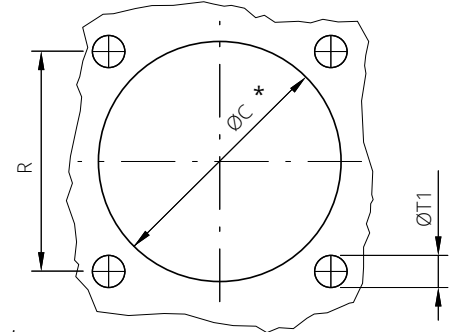

Panel cut out

* For installation with backshell mounted, consult our sales office.

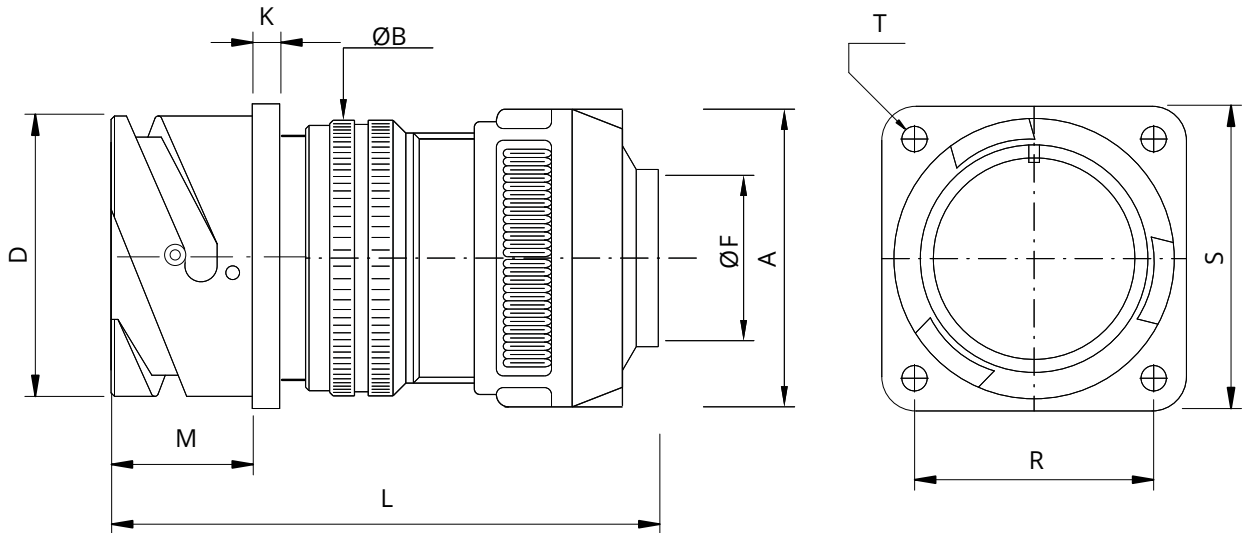

Shell size	ØD +0 -0.15	ØB ±0.2	L	K ±0.2	M ±0.2	A ±0.2	ØF cable dimension		R ±0.1	S ±0.3	ØT ±0.2	ØT1 Through holes	ØC* ±0.2
							Min	Max					
10SL	18.2	20	48.4	2.8	14.2	23	2.4	7.9	18.2	25.4	3.1	3.4	17
14S	24.6	24	56.1	3.2	14.5	26	5.8	11.2	23	30.2	3.1	3.4	20
16S	27.4	27	57.3	3.2	14.2	28.5	8	13.5	24.6	32.5	3.1	3.4	23
16	27.4	27	63.3	3.2	19	28.5	8	13.5	24.6	32.5	3.1	3.4	23
18	30.8	30	68	4	19	32	9.6	15.9	27	34.9	3.1	3.4	26.5
20	34.2	32	69.2	4	19	37.5	11.3	19	29.4	38.1	3.1	3.4	30
22	37.4	37	71.2	4	19.7	37.5	11.3	19	31.8	41	3.1	3.4	33
24	40.9	40	76.3	4	20.6	43.5	15.5	23.8	34.9	44.5	3.7	3.9	36
28	46.7	45	83.3	4	20.6	43.5	15.5	23.8	39.7	50.8	3.7	3.9	42
32	53.4	52	85.1	4	22.2	54	23.4	31.8	44.5	57	4.4	4.5	48.5
36	59.6	58	88.2	4	22.2	58	25.4	35	49.2	63.5	4.4	4.5	55
40	65.5	63.2	91.5	4	22.2	63.5	30	41.3	55.6	69.8	4.4	4.5	61

Dimensions in mm

Dimension "L" can be different from the value indicated according to backshells accessories, wires size and some special insert configurations.

CVBS - Bayonet Connector with protected mating ramps

RF	CVBS		00	AB	T	20-27	S	X		CR	CD5	F7	G	N
Series Code	Shell Material	Shell Type	Connector Class									Shell finish		

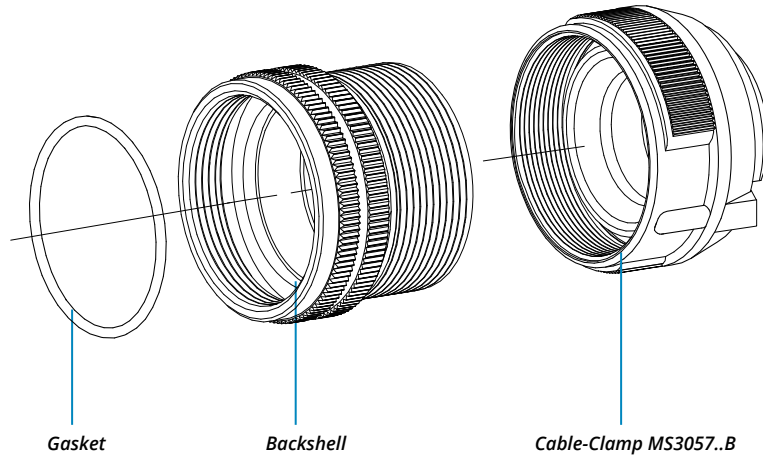

RF	Insulating material	-	Chloroprene rubber
		V	Fluoride rubber
		S	Silicone rubber
		RF	Fire resistant rubber
CVBS	Series Code	CVBS	Bayonet Connector with protected mating ramps
	Shell Material	-	Aluminum
00	Shell Type	00	Front mounting Receptacle
AB	Connector Class	AB	with waterproof O-ring
T	Connector Modification**	T	With plastic caps
		FF	Receptacle connector with threaded holes
		-	Receptacle connector with through holes
		FS	Receptacle connector with countersunk holes
20-27	Insert Arrangement		Size - Type

S	Contact Gender	S	Socket contacts
		P	Pin contacts
X	Polarization Code**		Alternate Positions
CR	Contact Termination	-	Solder contacts
		CR	Crimp contacts
		LC	Less contacts
CD5	Contact Plating	-	Silver plating
		CD5	Gold plating
F7	Shell finish	F5	Electroless nickel (*)
		F7	Black epoxy varnish (*)
		F16	CCF - Black passivation (*) - conductive
		F26	hard anodization (*)
G	Panel Gasket	-	Without gasket
		G	With waterproof panel gasket
		G2	With shielded panel gasket
		G3	With waterproof shielded panel gasket
N	Modification Code**	N	
		S	Consult our sales office

P/N Sample: RF CVBS 00ABT 20-27SX CR CD5 F7 G N

(*) RoHS compliance

(**) If required

CVBS - Bayonet Connector with protected mating ramps

Front Mounting Receptacle (00) with Backshell Class (ASF)

Connector provided with backshell, MS3057...A type Cable-Clamp (for single wire)

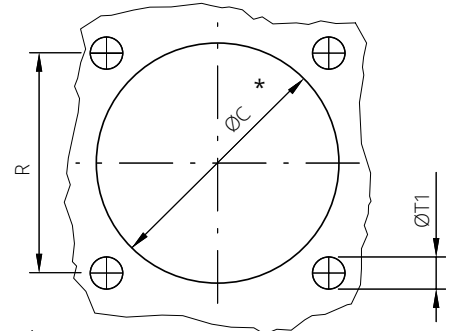

Panel cut out

* For installation with backshell mounted, consult our sales office.

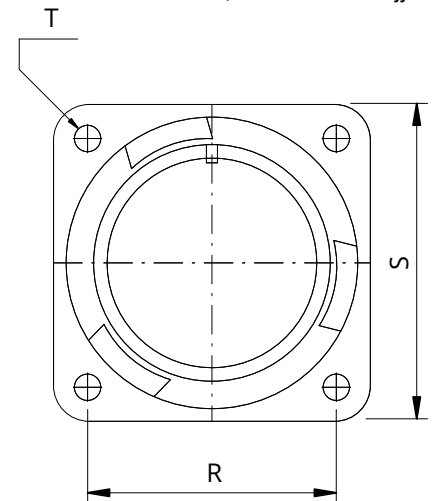
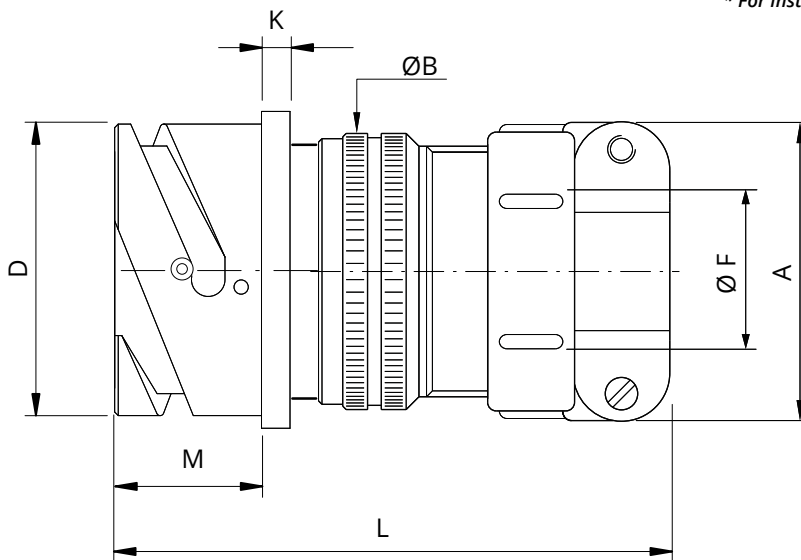

Shell size	ØD +0 -0.15	ØB ±0.2	L	K ±0.2	M ±0.2	A max	ØF cable max dimension	R ±0.1	S ±0.3	ØT ±0.2	ØT1 Through holes	ØC* ±0.2
10SL	18.2	20	51	2.8	14.2	22.5	8	18.2	25.4	3.1	3.4	17
14S	24.6	24	54.5	3.2	14.5	28	11	23	30.2	3.1	3.4	20
16S	27.4	27	56	3.2	14.2	30	14.2	24.6	32.5	3.1	3.4	23
16	27.4	27	63.5	3.2	19	30	14.2	24.6	32.5	3.1	3.4	23
18	30.8	30	66.5	4	19	31.7	15.8	27	34.9	3.1	3.4	26.5
20	34.2	32	66.5	4	19	37.5	19	29.4	38.1	3.1	3.4	30
22	37.4	37	69.5	4	19.7	37.5	19	31.8	41	3.1	3.4	33
24	40.9	40	69.5	4	20.6	43.5	23.8	34.9	44.5	3.7	3.9	36
28	46.7	45	77.5	4	20.6	43.5	23.8	39.7	50.8	3.7	3.9	42
32	53.4	52	78.5	4	22.2	51.7	31.7	44.5	57	4.4	4.5	48.5
36	59.6	58	78.5	4	22.2	58.5	35	49.2	63.5	4.4	4.5	55
40	65.5	63.2	92	4	22.2	68.5	41.2	55.6	69.8	4.4	4.5	61

Dimensions in mm

Dimension "L" can be different from the value indicated according to backshells accessories, wires size and some special insert configurations.

CVBS - Bayonet Connector with protected mating ramps

RF	CVBS		00	ASF	T	20-27	S	X		CR	CD5	F7	G	N
Series Code	Shell Material	Shell Type	Connector Class											Shell finish

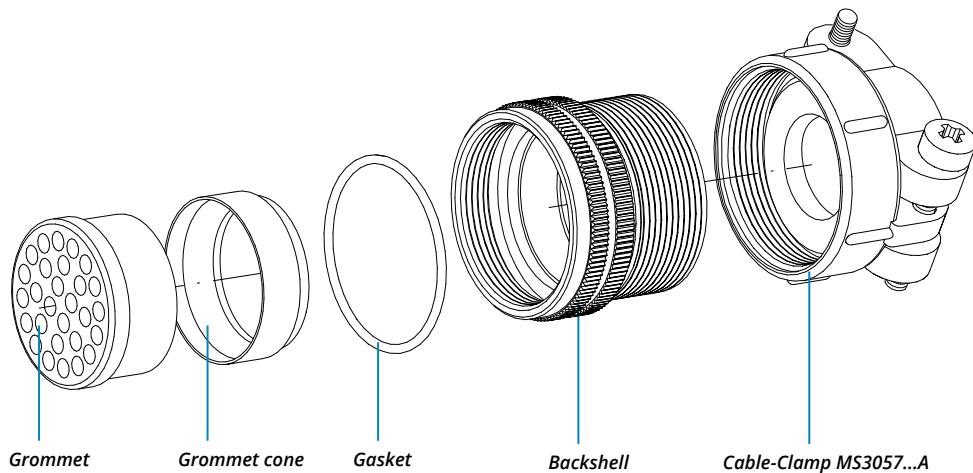

RF	Insulating material	-	Chloroprene rubber	S	Contact Gender	S	Socket contacts
		V	Fluoride rubber			P	Pin contacts
		S	Silicone rubber				
		RF	Fire resistant rubber				
CVBS	Series Code	CVBS	Bayonet Connector with protected mating ramps	X	Polarization Code**	Alternate Positions	
	Shell Material	-	Aluminum	CR	Contact Termination	-	Solder contacts
						CR	Crimp contacts
						LC	Less contacts
00	Shell Type	00	Front mounting Receptacle	CD5	Contact Plating	-	Silver plating
						CD5	Gold plating
ASF	Connector Class	ASF	with waterproof O-ring and grommet	F7	Shell finish	F5	Electroless nickel (*)
		T	With plastic caps			F7	Black epoxy varnish (*)
		FF	Receptacle connector with threaded holes			F16	CCF - Black passivation (*) - conductive
		-	Receptacle connector with through holes			F26	hard anodization (*)
T	Connector Modification**	-	Receptacle connector with countersunk holes			-	Without gasket
		FS	Receptacle connector with through holes	G	Panel Gasket	G	With waterproof panel gasket
						G2	With shielded panel gasket
						G3	With waterproof shielded panel gasket
20-27	Insert Arrangement		Size - Type	N	Modification Code**	N	Consult our sales office
						S	

P/N Sample: RF CVBS 00ASF T 20-27SX CR CD5 F7 G N

(*) RoHS compliance

(**) If required

CVBS - Bayonet Connector with protected mating ramps

Front Mounting Receptacle (00) with Backshell Class (DA..M - RA..M DA..PG - RA..PG)

Connector with backshell provided with an internal Metric or PG thread suitable for Cable Glands or conduit adapters.

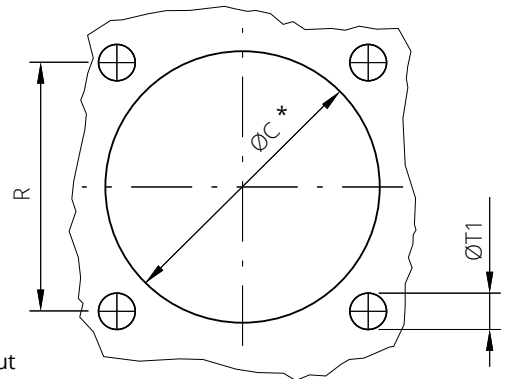

Panel cut out

* For installation with backshell mounted, consult our sales office.

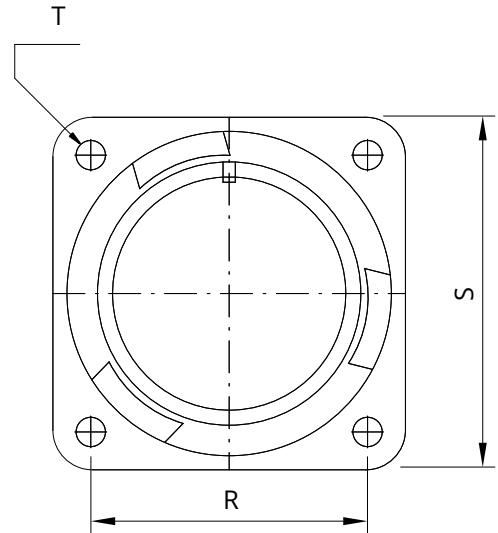
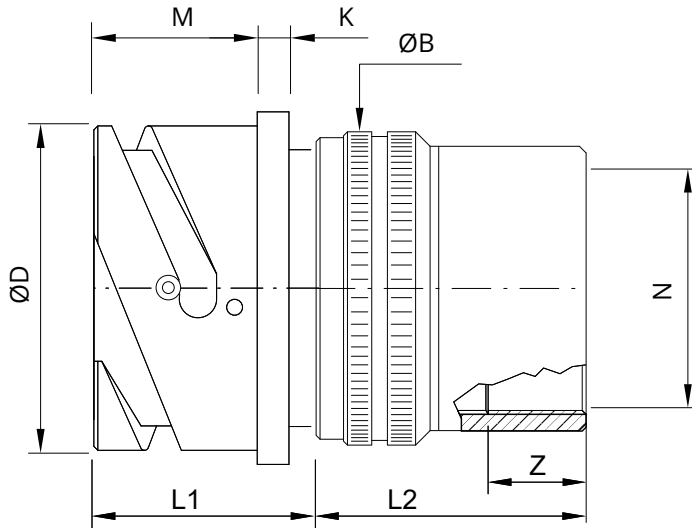

Shell size	ØD	ØB	M	K	Z	L1	N	L2	N	L2	R	S	ØT	ØT1	ØC*
	+0 -0.15	±0.2	±0.2	±0.2	min		Backshell Metric thread	M	Backshell PG Thread	PG ±0.1	±0.3	±0.2	Through holes	±0.2	
10SL	18.2	20	14.2	2.8	8	18,2	M12 - M16	32	(PG9) - PG13.5	26	18.2	25.4	3.1	3.4	17
14S	24.6	24	14.5	3.2	9	19,3	M12 - M16 - (M20) - (M25)	30	(PG9) - PG11 - PG13.5 - (PG16)	30	23	30.2	3.1	3.4	20
16S	27.4	27	14.2	3.2	9	18,5	(M16) - M20	40	PG13.5 - (PG16)	38	24.6	32.5	3.1	3.4	23
16	27.4	27	19	3.2	9	24,4	M20	45	-	40	24.6	32.5	3.1	3.4	23
18	30.8	30	19	4	9	24	M20 - M25	50	(PG11) - (PG13.5) - PG16 - PG21	50	27	34.9	3.1	3.4	26.5
20	34.2	32	19	4	9	24,2	M16 - M20 - M25 - (M32)	50	PG11-PG13.5-PG16-PG21-PG29	50	29.4	38.1	3.1	3.4	30
22	37.4	37	19.7	4	10	24,5	M16 - M20 - M25 - M32	50	PG13.5 - (PG16) - (PG29)	50	31.8	41	3.1	3.4	33
24	40.9	40	20.6	4	10	25,7	M20 - M25 - M32 - M40	50	PG16 - PG21 - PG29	50	34.9	44.5	3.7	3.9	36
28	46.7	45	20.6	4	10	26,1	(M25) - M32 - M40	63	PG21 - PG29 - PG36	60	39.7	50.8	3.7	3.9	42
32	53.4	52	22.2	4	10	27,9	(M25) - (M32) - M40	55	PG21 - (PG29) - PG36	60	44.5	57	4.4	4.5	48.5
36	59.6	58	22.2	4	13	28,7	M40 - M50	56	PG29 - (PG36) - (PG42)	65	49.2	63.5	4.4	4.5	55
40	65.5	63.2	22.2	4	13	28	M40 - (M50) - M63	65	PG29 - (PG36) - (PG42) - (PG48)	65	55.6	69.8	4.4	4.5	61

Dimensions in mm

Dimensions "L1 and L2" can be different from the value indicated according to backshells accessories, wires size and some special insert configurations.

(...) The threads in parentheses are versions on request with non standard backshell length (the dimensions L2 and Z are different from this page indication).

Please consult our sales office for the specific dimensions.

CVBS - Bayonet Connector with protected mating ramps



Series Code **Shell Material** **Shell Type** **Connector Class**

Backshell internal thread

Shell finish

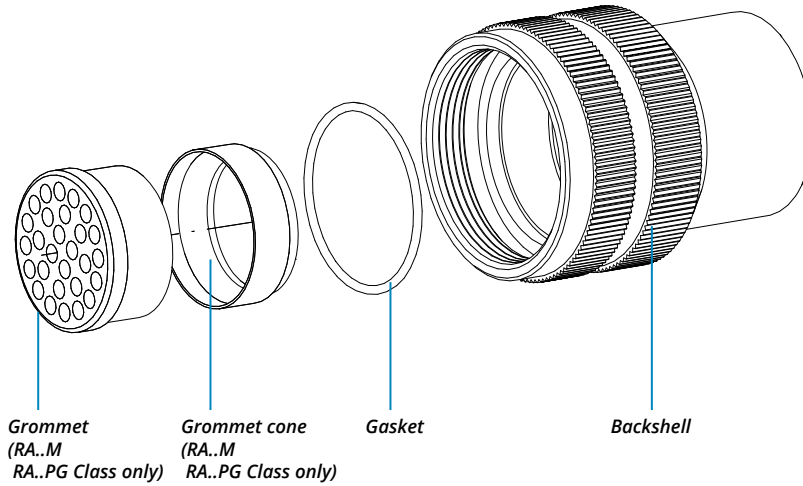

RF	Insulating material	-	Chloroprene rubber
		V	Fluoride rubber
		S	Silicone rubber
		RF	Fire resistant rubber
CVBS	Series Code	CVBS	Bayonet Connector with protected mating ramps
[]	Shell Material	-	Aluminum
00	Shell Type	00	Front mounting Receptacle
DA	Connector Class	DA	with waterproof O-ring (IP67***)
		RA	with waterproof O-ring and grommet (IP67***)
		T	With plastic caps
		FF	Receptacle connector with threaded holes
T	Connector Modification**	-	Receptacle connector with through holes
		FS	Receptacle connector with countersunk holes
		20-27	Insert Arrangement
S	Contact Gender	S	Socket contacts
		P	Pin contacts

X	Polarization Code**		Alternate Positions
M12	Backshell internal thread	M	Provided with an internal Metric thread
		PG	Provided with an internal PG thread
CR	Contact Termination	-	Solder contacts
		CR	Crimp contacts
		LC	Less contacts
CD5	Contact Plating	-	Silver plating
		CD5	Gold plating
F7	Shell finish	F5	Electroless nickel (*)
		F7	Black epoxy varnish (*)
		F16	CCF - Black passivation (*) - conductive
		F26	hard anodization (*)
G	Panel Gasket	-	Without gasket
		G	With waterproof panel gasket
		G2	With shielded panel gasket
N	Modification Code**	G3	With waterproof shielded panel gasket
		N	
		S	Consult our sales office

*** Protection degree: IP 67 (only in the mating area with mated connectors) according to EN 60529 (*) RoHS compliance (**) If required

P/N Sample: RF CVBS 00DAT 20-27SX M12 CR CD5 F7 G N

CVBS - Bayonet Connector with protected mating ramps

Front Mounting Receptacle (00) with Backshell Class (DA.MH - RA.MH DA.PH - RA.PH)

Connector with backshell provided with a Metric or PG thread metal Cable Glands.

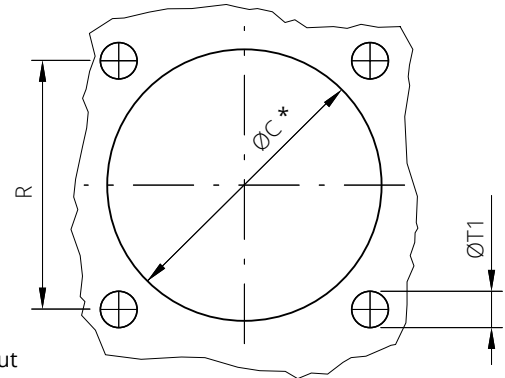

Panel cut out

* For installation with backshell mounted, consult our sales office.

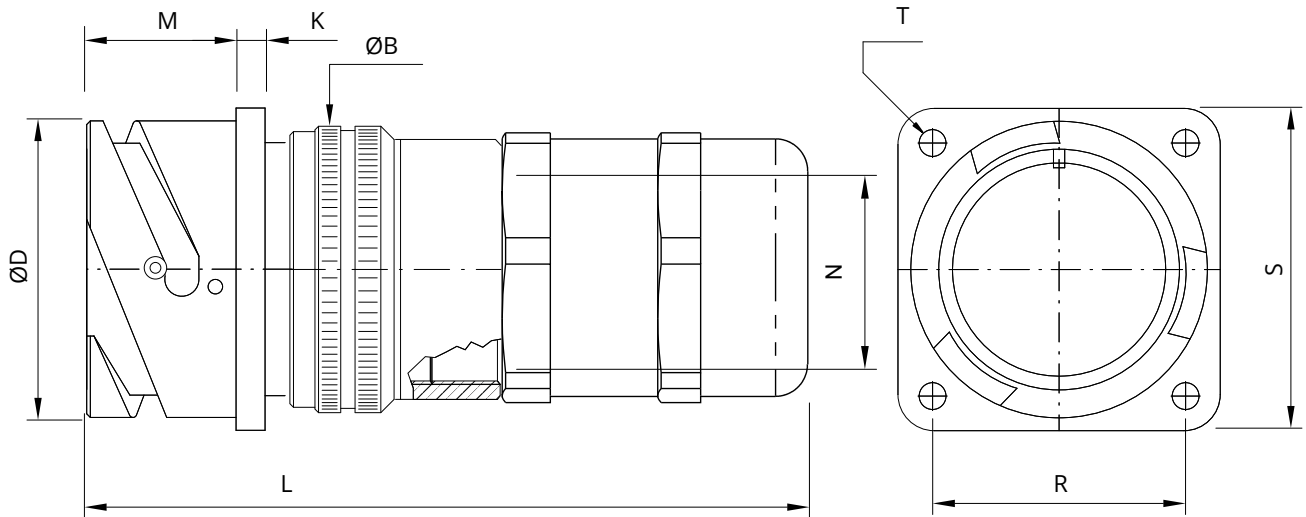

Shell size	ØD +0 -0.15	ØB ±0.2	L max	K ±0.2	M ±0.2	Backshell Metric Thread	ØN Clamping range	R ±0.1	S ±0.3	ØT ±0.2	ØT1 Through holes	ØC* ±0.2
10SL	18.2	20	87	2.8	14.2	M12	3.5-7	18.2	25.4	3.1	3.4	17
14S	24.6	24	93	3.2	14.5	M16	4.5-10	23	30.2	3.1	3.4	20
16S	27.4	27	96.5	3.2	14.2	M20	7-13	24.6	32.5	3.1	3.4	23
16	27.4	27	103.5	3.2	19	M20	7-13	24.6	32.5	3.1	3.4	23
18	30.8	30	103.5	4	19	M20	7-13	27	34.9	3.1	3.4	26.5
20	34.2	32	104.5	4	19	M25	9-17	29.4	38.1	3.1	3.4	30
22	37.4	37	110.5	4	19.7	M32	11-21	31.8	41	3.1	3.4	33
24	40.9	40	112.5	4	20.6	M32	11-21	34.9	44.5	3.7	3.9	36
28	46.7	45	122.5	4	20.6	M32	11-21	39.7	50.8	3.7	3.9	42
32	53.4	52	127	4	22.2	M40	19-28	44.5	57	4.4	4.5	48.5
36	59.6	58	132	4	22.2	M40	19-28	49.2	63.5	4.4	4.5	55
40	65.5	63.2	138	4	22.2	M40	19-28	55.6	69.8	4.4	4.5	61

Dimensions in mm

Dimension "L" can be different from the value indicated according to backshells accessories, wires size and some special insert configurations.

CVBS - Bayonet Connector with protected mating ramps



Series Code **Shell Material Type** **Shell Type** **Connector Class**

Backshell internal thread

Shell finish

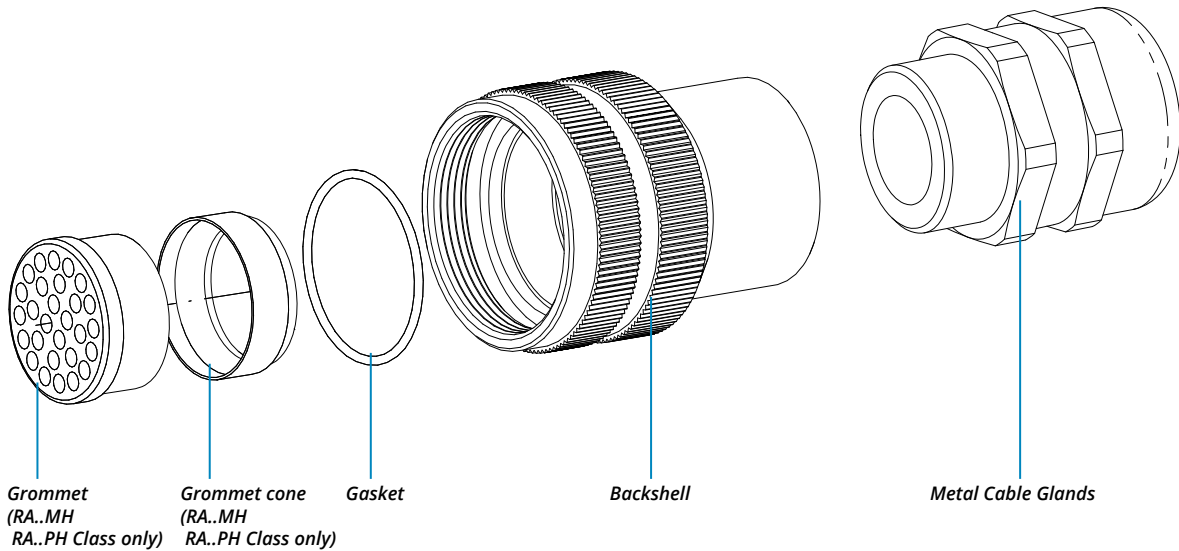

RF	Insulating material	-	Chloroprene rubber
		V	Fluoride rubber
		S	Silicone rubber
		RF	Fire resistant rubber
CVBS	Series Code	CVBS	Bayonet Connector with protected mating ramps
	Shell Material	-	Aluminum
00	Shell Type	00	Front mounting Receptacle
DA	Connector Class	DA	with waterproof O-ring (IP67)
		RA	with waterproof O-ring and grommet (IP67)
		T	With plastic caps
		FF	Receptacle connector with threaded holes
T	Connector Modification**	-	Receptacle connector with through holes
		FS	Receptacle connector with countersunk holes
20-27	Insert Arrangement		Size - Type
S	Contact Gender	S	Socket contacts
		P	Pin contacts

X	Polarization Code**		Alternate Positions
MH12	Backshell internal thread	MH	Provided with a Metric thread Cable Glands
		PH	Provided with a PG thread Cable Glands***
CR	Contact Termination	-	Solder contacts
		CR	Crimp contacts
		LC	Less contacts
CD5	Contact Plating	-	Silver plating
		CD5	Gold plating
F7	Shell finish	F5	Electroless nickel (*)
		F7	Black epoxy varnish (*)
		F16	CCF - Black passivation (*) - conductive
		F26	hard anodization (*)
		-	Without gasket
G	Panel Gasket	G	With waterproof panel gasket
		G2	With shielded panel gasket
		G3	With waterproof shielded panel gasket
N	Modification Code**	N	
		S	Consult our sales office

P/N Sample: RF CVBS 00DAT 20-27SX MH12 CR CD5 F7 G N (*) RoHS compliance (***) If required *** Consult our sales office

CVBS - Bayonet Connector with protected mating ramps

Front Mounting Receptacle (00) with Backshell Class (AR-R)

This class is suitable to connect single wires when strain relief is not necessary and small longitudinal overall dimensions are needed. As watertightness is guaranteed by the grommet only, it is necessary to make sure the wire diameter matches the grommet sealing range.

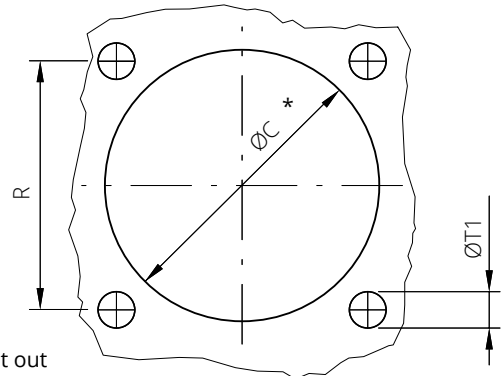

Panel cut out

* For installation with backshell mounted, consult our sales office.

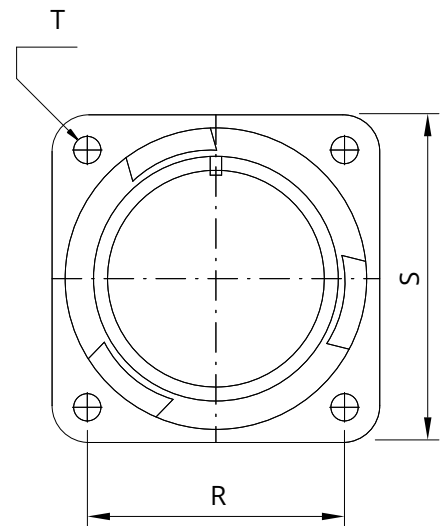
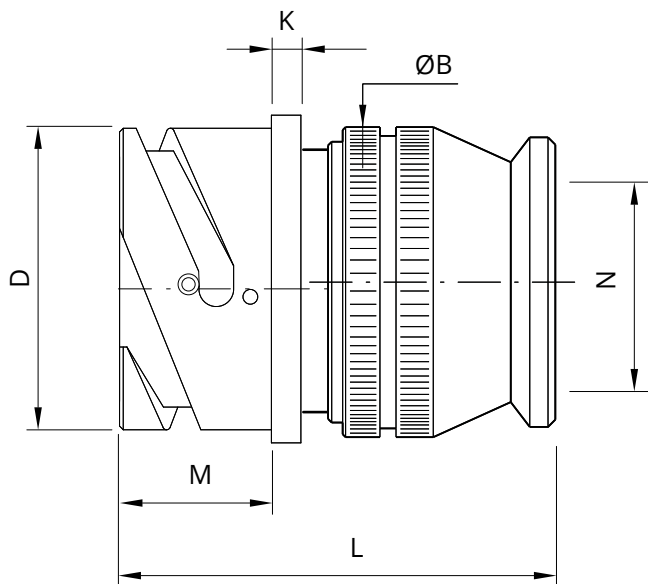

Shell size	ØD +0 -0.15	ØB ±0.2	L	K ±0.2	M ±0.2	N max cable dimension	R ±0.1	S ±0.3	ØT ±0.2	ØT1 Through holes	ØC* ±0.2
10SL	18.2	20	35	2.8	14.2	10	18.2	25.4	3.1	3.4	17
14S	24.6	24	35.5	3.2	14.5	13.5	23	30.2	3.1	3.4	20
16S	27.4	27	39	3.2	14.2	16.1	24.6	32.5	3.1	3.4	23
16	27.4	27	48.5	3.2	19	16.5	24.6	32.5	3.1	3.4	23
18	30.8	29.4	50	4	19	19	27	34.9	3.1	3.4	26.5
20	34.2	32	50	4	19	22.2	29.4	38.1	3.1	3.4	30
22	37.4	37	52	4	19.7	24.5	31.8	41	3.1	3.4	33
24	40.9	40	55.6	4	20.6	28	34.9	44.5	3.7	3.9	36
28	46.7	45	56	4	20.6	32.6	39.7	50.8	3.7	3.9	42
32	53.4	52	58	4	22.2	38	44.5	57	4.4	4.5	48.5
36	59.6	58	61.5	4	22.2	45	49.2	63.5	4.4	4.5	55
40	65.5	63.2	59	4	22.2	51.3	55.6	69.8	4.4	4.5	61

Dimensions in mm

Dimension "L" can be different from the value indicated according to backshells accessories, wires size and some special insert configurations.

CVBS - Bayonet Connector with protected mating ramps



Series Shell Shell Connector
Code Material Type Class

Shell
finish

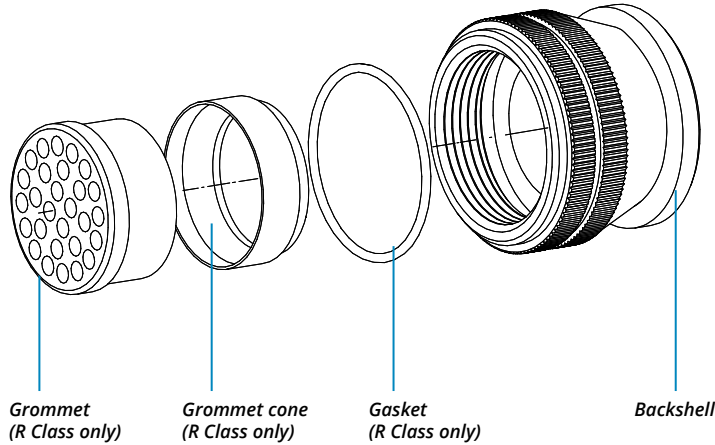

The accessories for this class are not always available in stock for all sizes; we suggest you consult our Sales Office for availability

RF	Insulating material	-	Chloroprene rubber	S	Contact Gender	S	Socket contacts
		V	Fluoride rubber			P	Pin contacts
		S	Silicone rubber				
		RF	Fire resistant rubber				
CVBS	Series Code	CVBS	Bayonet Connector with protected mating ramps	X	Polarization Code**		Alternate Positions
	Shell Material	-	Aluminum	CR	Contact Termination	-	Solder contacts
				CR		CR	Crimp contacts
				LC		LC	Less contacts
00	Shell Type	00	Front mounting Receptacle	CD5	Contact Plating	-	Silver plating
				CD5		CD5	Gold plating
R	Connector Class	AR	non watertight	F7	Shell finish	F5	Electroless nickel (*)
		R	With O-ring and grommet			F7	Black epoxy varnish (*)
		T	With plastic caps			F16	CCF - Black passivation (*) - conductive
		FF	Receptacle connector with threaded holes			F26	hard anodization (*)
T	Connector Modification**	-	Receptacle connector with through holes			-	Without gasket
		FS	Receptacle connector with countersunk holes	G	Panel Gasket	G	With waterproof panel gasket
				G2	With shielded panel gasket		
20-27	Insert Arrangement		Size - Type	G3	With waterproof shielded panel gasket		
				N	Modification Code**	N	Consult our sales office
				S		S	

P/N Sample: RF CVBS 00RT 20-27SX CR CD5 F7 G N

(*) RoHS compliance

(**) If required

CVBS - Bayonet Connector with protected mating ramps

Front Mounting Receptacle (00) with Backshell Class (AG-G)

These classes of connectors are all suitable for heat shrink tubing applications.

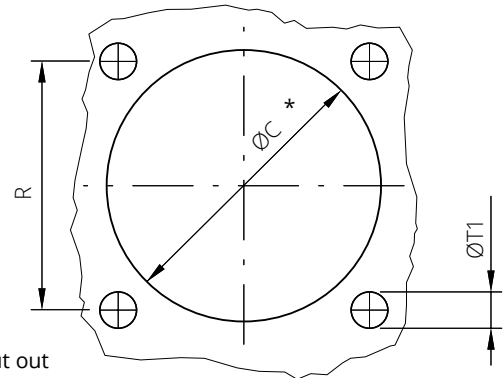

Panel cut out

* For installation with backshell mounted, consult our sales office.

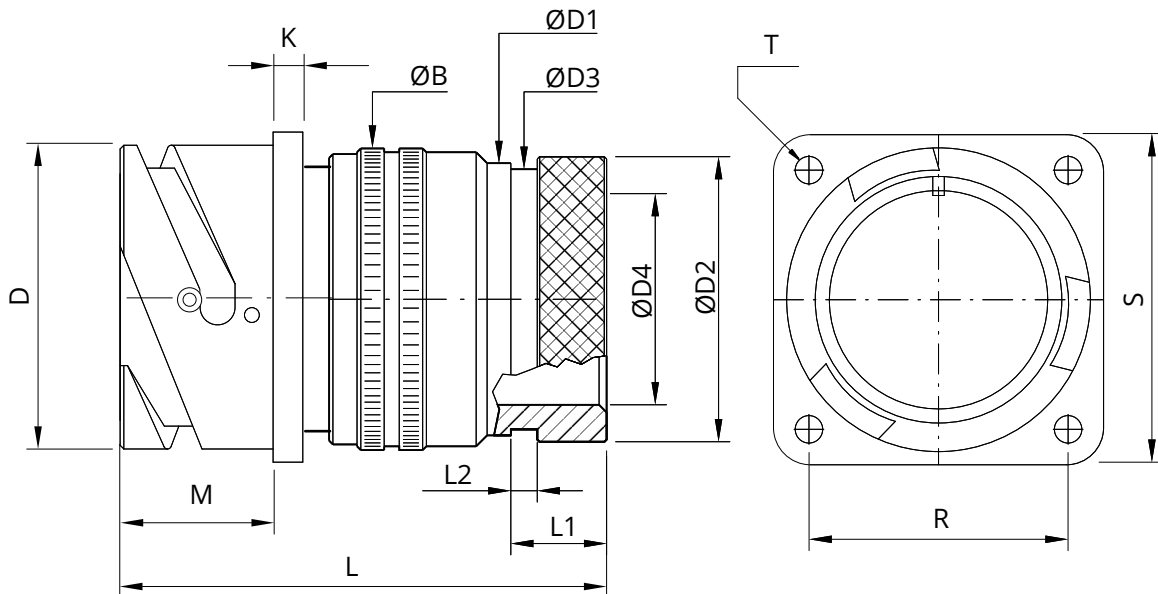

Shell size	ØD +0 -0.15	ØB ±0.2	ØD1 ±0.2	ØD2 ±0.2	ØD3 ±0.2	ØD4 ±0.2	L	L1 ±0.2	L2 ±0.2	K ±0.2	M ±0.2	R ±0.1	S ±0.3	ØT ±0.2	ØT1 Through holes	ØC* ±0.2
10SL	18.2	20	17	15.5	13.3	7.9	48	11.7	3.5	2.8	14.2	18.2	25.4	3.1	3.4	17
14S	24.6	24	20.1	19.1	17	13.5	48	11.7	3.5	3.2	14.5	23	30.2	3.1	3.4	20
16S	27.4	27	23.5	23.9	21.9	13.7	48	11.7	3.5	3.2	14.2	24.6	32.5	3.1	3.4	23
16	27.4	27	23.5	23.9	21.9	16.1	60	11.5	3.5	3.2	19	24.6	32.5	3.1	3.4	23
18	30.8	30	26.5	23.9	21.9	19	65	11.5	3.5	4	19	27	34.9	3.1	3.4	26.5
20	34.2	33	30.2	29.6	26.2	22.2	65	12.4	3.5	4	19	29.4	38.1	3.1	3.4	30
22	37.4	37	33.6	29.6	26.2	22	65	12.7	3.5	4	19.7	31.8	41	3.1	3.4	33
24	40.9	40	36.1	37.8	34.5	28	65	12.7	3.5	4	20.6	34.9	44.5	3.7	3.9	36
28	46.7	45	41.4	37.8	34.5	29	65	12.7	3.5	4	20.6	39.7	50.8	3.7	3.9	42
32	53.4	52	50	47.8	43.4	35.2	70	15.2	3.5	4	22.2	44.5	57	4.4	4.5	48.5
36	59.6	57.2	56	47.7	43.4	40	75	15.2	3.5	4	22.2	49.2	63.5	4.4	4.5	55
40	65.5	63.6	62.4	57.6	52.4	48	77	15.2	3.5	4	22.2	55.6	69.8	4.4	4.5	61

Dimensions in mm

Dimension "L" can be different from the value indicated according to backshells accessories, wires size and some special insert configurations.

CVBS - Bayonet Connector with protected mating ramps



Series Shell Shell Connector
Code Material Type Class

Shell
finish

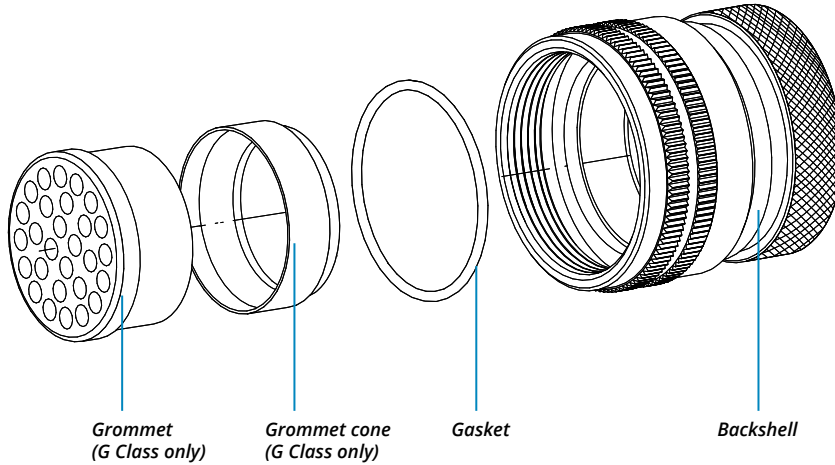

The accessories for this class are not always available in stock for all sizes; we suggest you consult our Sales Office for availability

RF	Insulating material	-	Chloroprene rubber	S	Contact Gender	S	Socket contacts
		V	Fluoride rubber			P	Pin contacts
		S	Silicone rubber				
		RF	Fire resistant rubber				
CVBS	Series Code	CVBS	Bayonet Connector with protected mating ramps	X	Polarization Code**		Alternate Positions
[]	Shell Material	-	Aluminum	CR	Contact Termination	-	Solder contacts
						CR	Crimp contacts
						LC	Less contacts
00	Shell Type	00	Front mounting Receptacle	CD5	Contact Plating	-	Silver plating
						CD5	Gold plating
AG	Connector Class	AG	With waterproof O-ring (IP67***)	F7	Shell finish	F5	Electroless nickel (*)
		G	With waterproof O-ring and grommet (IP67***)			F7	Black epoxy varnish (*)
		T	With plastic caps			F16	CCF - Black passivation (*) - conductive
		FF	Receptacle connector with threaded holes			F26	hard anodization (*)
T	Connector Modification**	-	Receptacle connector with through holes	G	Panel Gasket	-	Without gasket
						G	With waterproof panel gasket
						G2	With shielded panel gasket
						G3	With waterproof shielded panel gasket
20-27	Insert Arrangement		Size - Type	N	Modification Code**	N	Consult our sales office
						S	

*** Protection degree: IP 67 (only in the mating area with mated connectors) according to EN 60529 (*) RoHS compliance (***) If required

P/N Sample: RF CVBS 00AGT 20-27SX CR CD5 F7 G N

CVBS - Bayonet Connector with protected mating ramps

Front Mounting Receptacle (00) with Backshell Class (AG2 - G2)

These classes of connectors are all suitable for heat shrink tubing applications. Two piece backshell includes nut for shell tightening. Internal serration prevents backshell rotation and allows easy assembling after contacts are inserted.

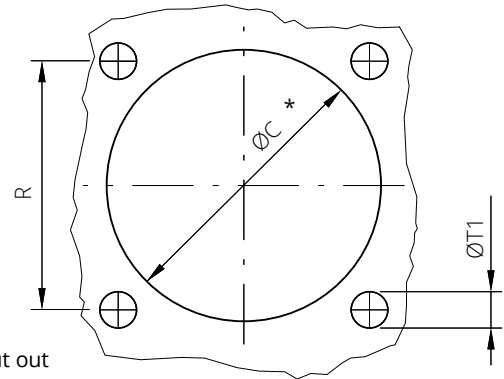

Panel cut out

* For installation with backshell mounted, consult our sales office.

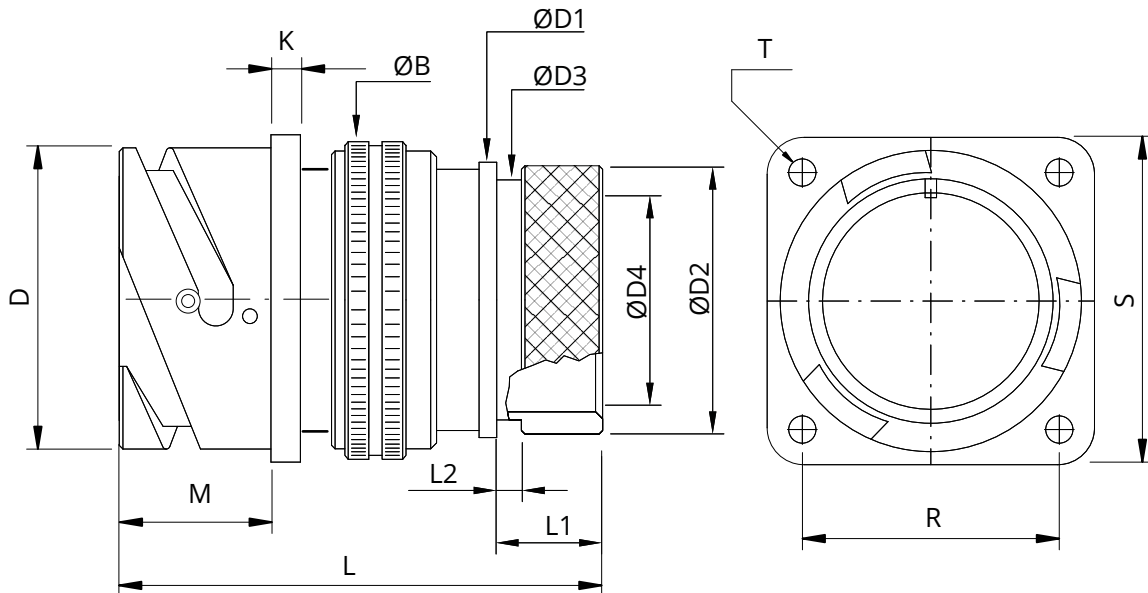

Shell size	ØD +0 -0.15	ØB ±0.2	ØD1 ±0.2	ØD2 ±0.2	ØD3 ±0.2	ØD4 ±0.2	L	L1 ±0.2	L2 ±0.2	K ±0.2	M ±0.2	R ±0.1	S ±0.3	ØT ±0.2	ØT1 Through holes	ØC* ±0.2
10SL	18.2	22.5	17	15.5	13.3	8.6	51	11.7	3.5	2.8	14.2	18.2	25.4	3.1	3.4	17
14S	24.6	26	20.1	19.1	17	10.8	51	11.7	3.5	3.2	14.5	23	30.2	3.1	3.4	20
16S	27.4	29	23.5	23.9	21.9	14	51	11.7	3.5	3.2	14.2	24.6	32.5	3.1	3.4	23
16	27.4	29	23.5	23.9	21.9	14	62	11.5	3.5	3.2	19	24.6	32.5	3.1	3.4	23
18	30.8	33.4	26.5	23.9	21.9	14.8	63	11.5	3.5	4	19	27	34.9	3.1	3.4	26.5
20	34.2	37	30.2	29.6	26.2	19.3	63	12.4	3.5	4	19	29.4	38.1	3.1	3.4	30
22	37.4	41	33.6	29.6	26.2	22.5	63	12.7	3.5	4	19.7	31.8	41	3.1	3.4	33
24	40.9	45.9	36.1	37.8	34.5	28	64	12.7	3.5	4	20.6	34.9	44.5	3.7	3.9	36
28	46.7	51	41.4	37.8	34.5	28	66	12.7	3.5	4	20.6	39.7	50.8	3.7	3.9	42
32	53.4	58	50	47.8	43.4	34.8	67	15.2	3.5	4	22.2	44.5	57	4.4	4.5	48.5
36	59.6	60.5	56	47.7	43.4	38.7	67	15.2	3.5	4	22.2	49.2	63.5	4.4	4.5	55
40	65.5	69	62.4	57.6	52.4	48.2	68	15.2	3.5	4	22.2	55.6	69.8	4.4	4.5	61

Dimensions in mm

Dimension "L" can be different from the value indicated according to backshells accessories, wires size and some special insert configurations.

CVBS - Bayonet Connector with protected mating ramps



Series Shell Shell Connector
Code Material Type Class

Shell
finish

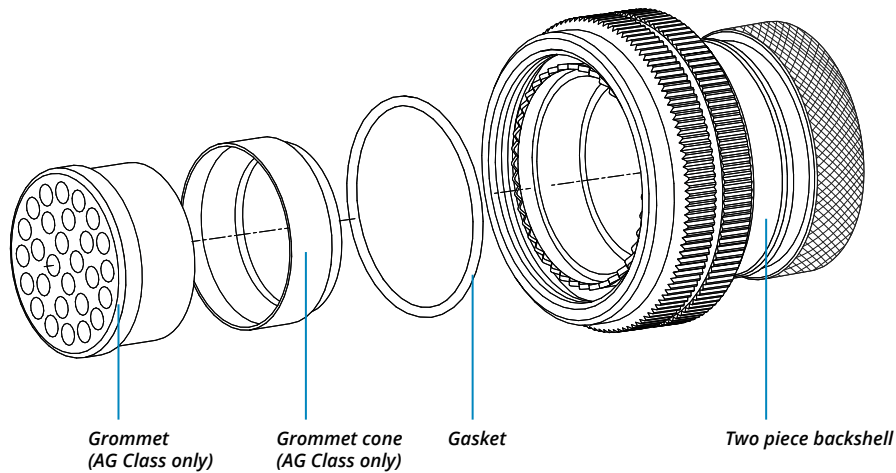

The accessories for this class are not always available in stock for all sizes; we suggest you consult our Sales Office for availability

RF	Insulating material	-	Chloroprene rubber	S	Contact Gender	S	Socket contacts
		V	Fluoride rubber			P	Pin contacts
		S	Silicone rubber				
		RF	Fire resistant rubber				
CVBS	Series Code	CVBS	Bayonet Connector with protected mating ramps	X	Polarization Code**		Alternate Positions
	Shell Material	-	Aluminum	CR	Contact Termination	-	Solder contacts
				CR		CR	Crimp contacts
				LC		LC	Less contacts
00	Shell Type	00	Front mounting Receptacle	CD5	Contact Plating	-	Silver plating
				CD5		CD5	Gold plating
G2	Connector Class	AG2	With waterproof O-ring (IP67***)	F7	Shell finish	F5	Electroless nickel (*)
		G2	With waterproof O-ring and grommet (IP67***)#			F7	Black epoxy varnish (*)
		T	With plastic caps			F16	CCF - Black passivation (*) - conductive
		FF	Receptacle connector with threaded holes			F26	hard anodization (*)
T	Connector Modification**	-	Receptacle connector with through holes	-		-	Without gasket
		FS	Receptacle connector with countersunk holes	G	Panel Gasket	G	With waterproof panel gasket
				G2	With shielded panel gasket		
20-27	Insert Arrangement		Size - Type	G3		G3	With waterproof shielded panel gasket
				N	Modification Code**	N	Consult our sales office
				S		S	Consult our sales office

*** Protection degree: IP 67 (only in the mating area with mated connectors) according to EN 60529

(*) RoHS compliance (***) If required

P/N Sample: RF CVBS 00G2T 20-27SX CR CD5 F7 G N

(#) In some sizes the grommet cone is not needed

CVBS - Bayonet Connector with protected mating ramps

Front Mounting Receptacle (00) with Backshell Class (ASB1 - SB1)

Backshell for multicore jacketed shielded cables, provided with MS 3057...C type Cable-Clamp. (for jacketed cable)
Also available versions for over/under dimensioned cables.

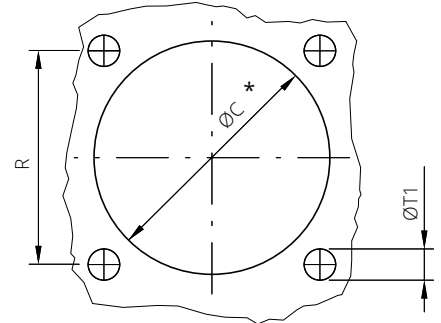

Panel cut out

* For installation with backshell mounted, consult our sales office.

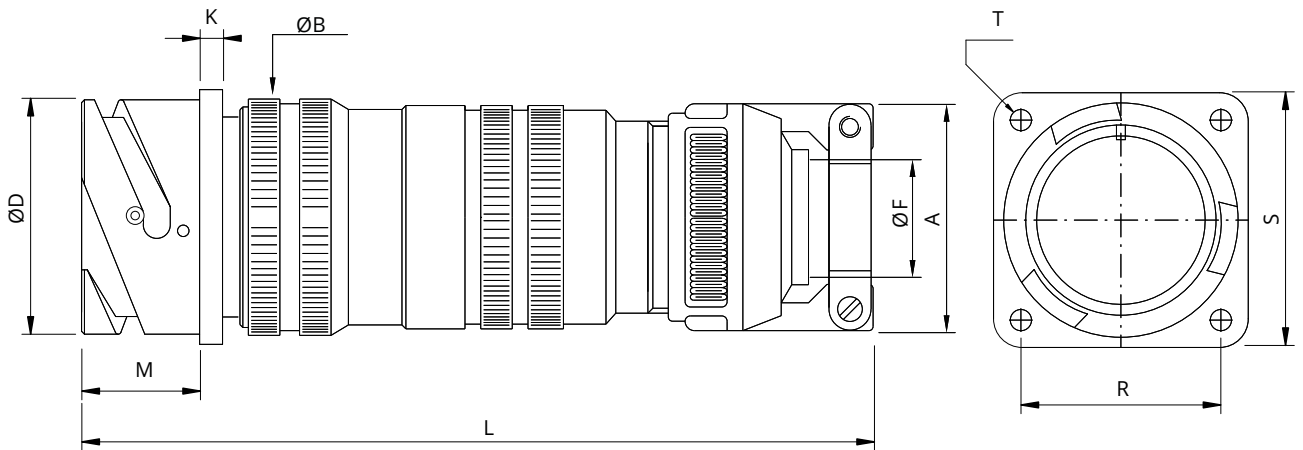

Shell size	ØD +0 -0.15	ØB ±0.2	K ±0.2	L	M ±0.2	A ±0.2	ØF cable dimension		R ±0.1	S ±0.3	ØT ±0.2	ØT1 Through holes	ØC* ±0.2
							Min	Max					
10SL	18.2	20	2.8	99	14.2	23	2.4	7.9	18.2	25.4	3.1	3.4	17
14S	24.6	24	3.2	99	14.5	26	5.8	11.2	23	30.2	3.1	3.4	20
16S	27.4	27	3.2	100	14.2	28.5	8	13.5	24.6	32.5	3.1	3.4	23
16	27.4	27	3.2	118	19	28.5	8	13.5	24.6	32.5	3.1	3.4	23
18	30.8	32	4	124	19	32	9.6	15.9	27	34.9	3.1	3.4	26.5
20	34.2	35	4	124	19	37.5	11.3	19	29.4	38.1	3.1	3.4	30
22	37.4	37	4	124	19.7	37.5	11.3	19	31.8	41	3.1	3.4	33
24	40.9	42	4	135	20.6	43.5	15.5	23.8	34.9	44.5	3.7	3.9	36
28	46.7	45	4	138	20.6	43.5	15.5	23.8	39.7	50.8	3.7	3.9	42
32	53.4	50	4	146	22.2	54	23.4	31.8	44.5	57	4.4	4.5	48.5
36	59.6	58	4	150	22.2	58	25.4	35	49.2	63.5	4.4	4.5	55
40	65.5	63.8	4	154	22.2	63.5	30	41.3	55.6	69.8	4.4	4.5	61

Dimensions in mm

Dimension "L" can be different from the value indicated according to backshells accessories, wires size and some special insert configurations.

CVBS - Bayonet Connector with protected mating ramps

RF	CVBS		00	ASB1	T	20-27	S	X		CR	CD5	F7	G	N
Series Code	Shell Material	Shell Type	Connector Class									Shell finish		

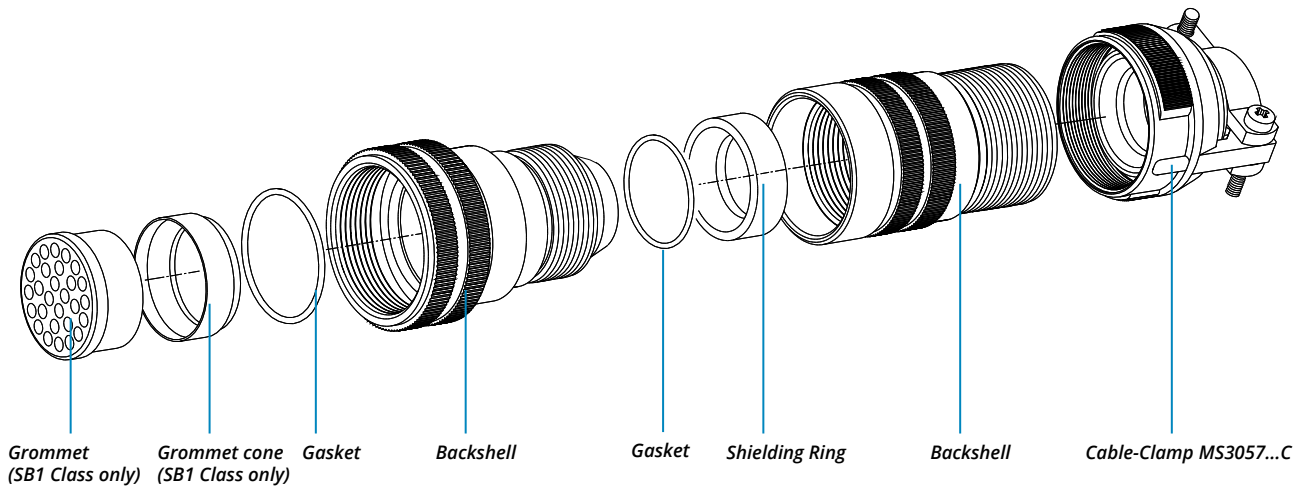

The accessories for this class are not always available in stock for all sizes; we suggest you consult our Sales Office for availability

RF	Insulating material	-	Chloroprene rubber	S	Contact Gender	S	Socket contacts
		V	Fluoride rubber			P	Pin contacts
		S	Silicone rubber				
		RF	Fire resistant rubber				
CVBS	Series Code	CVBS	Bayonet Connector with protected mating ramps	X	Polarization Code**		Alternate Positions
	Shell Material	-	Aluminum	CR	Contact Termination	-	Solder contacts
				CR		CR	Crimp contacts
				LC		LC	Less contacts
00	Shell Type	00	Front mounting Receptacle	CD5	Contact Plating	-	Silver plating
				CD5		CD5	Gold plating
ASB1	Connector Class	ASB1	with waterproof O-ring (IP67)	F7	Shell finish	F5	Electroless nickel (*)
		SB1	with waterproof O-ring and grommet (IP67)#			F7	Black epoxy varnish (*)
		T	With plastic caps			F16	CCF - Black passivation (*) - conductive
		FF	Receptacle connector with threaded holes			F26	hard anodization (*)
T	Connector Modification**	-	Receptacle connector with through holes			-	Without gasket
		FF	Receptacle connector with threaded holes	G	Panel Gasket	G	With waterproof panel gasket
		FS	Receptacle connector with countersunk holes	G2		G2	With shielded panel gasket
				G3		G3	With waterproof shielded panel gasket
20-27	Insert Arrangement		Size - Type	N	Modification Code**	N	Consult our sales office
				S		S	Consult our sales office

P/N Sample: RF CVBS 00SB1T 20-27SX CR CD5 F7 G N

(*) RoHS compliance (**) If required
 (#) In some sizes the grommet cone is not needed

CVBS - Bayonet Connector with protected mating ramps

Front Mounting Receptacle (00) with Backshell Class (AGV - GV)

These classes of connectors are provided with backshell for shield hose and heat shrink tubing termination. It comes complete with conical protection spring, also suitable for thin shield braid.

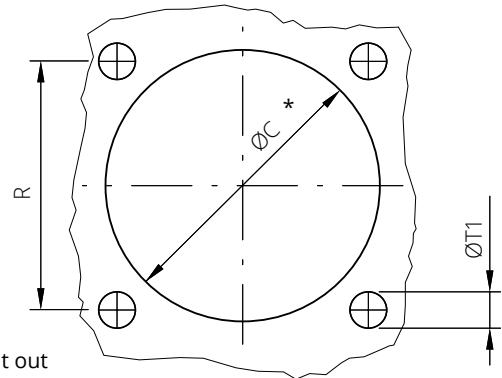

Panel cut out

* For installation with backshell mounted, consult our sales office.

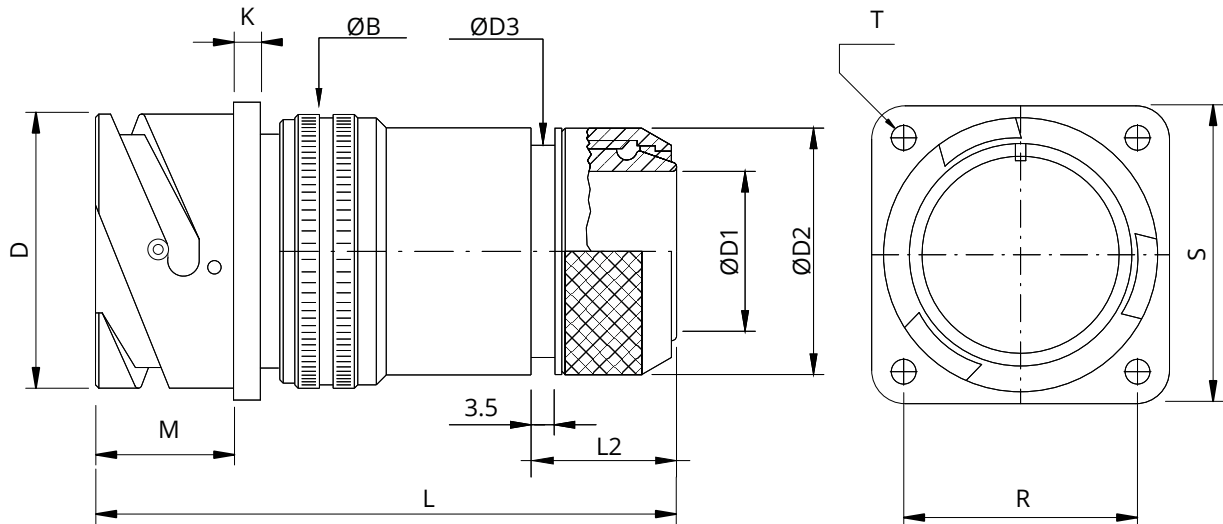

Shell size	ØD +0 -0.15	ØB ±0.2	ØD1 ±0.2	ØD2 ±0.2	ØD3 ±0.2	L	L2 ±0.2	K ±0.2	M ±0.2	R ±0.1	S ±0.3	ØT ±0.2	ØT1 Through holes	ØC* ±0.2
10SL	18.2	20	8.6	18.5	16.3	65	18	2.8	14.2	18.2	25.4	3.1	3.4	17
14S	24.6	24	10.6	22	20	65	17.6	3.2	14.5	23	30.2	3.1	3.4	20
16S	27.4	27	10.4	25	23	65	20.7	3.2	14.2	24.6	32.5	3.1	3.4	23
16	27.4	27	13.5	25	23	74	20.8	3.2	19	24.6	32.5	3.1	3.4	23
18	30.8	30	14.5	28	24.5	75	20.8	4	19	27	34.9	3.1	3.4	26.5
20	34.2	32	18.4	32	28.5	75	20.8	4	19	29.4	38.1	3.1	3.4	30
22	37.4	37	20.7	34	30.5	75	20.8	4	19.7	31.8	41	3.1	3.4	33
24	40.9	40	24.6	38.5	34.5	81	20.7	4	20.6	34.9	44.5	3.7	3.9	36
28	46.7	46	25	40	36	81	21.8	4	20.6	39.7	50.8	3.7	3.9	42
32	53.4	52	33.3	48	44	83	20.7	4	22.2	44.5	57	4.4	4.5	48.5
36	59.6	58	38.5	55	51	83	20.7	4	22.2	49.2	63.5	4.4	4.5	55
40	65.5	63.8	46	62	58	83	21.8	4	22.2	55.6	69.8	4.4	4.5	61

Dimensions in mm

Dimension "L" can be different from the value indicated according to backshells accessories, wires size and some special insert configurations.

CVBS - Bayonet Connector with protected mating ramps



Series Code Shell Material Type Shell Class Connector Class

Shell finish

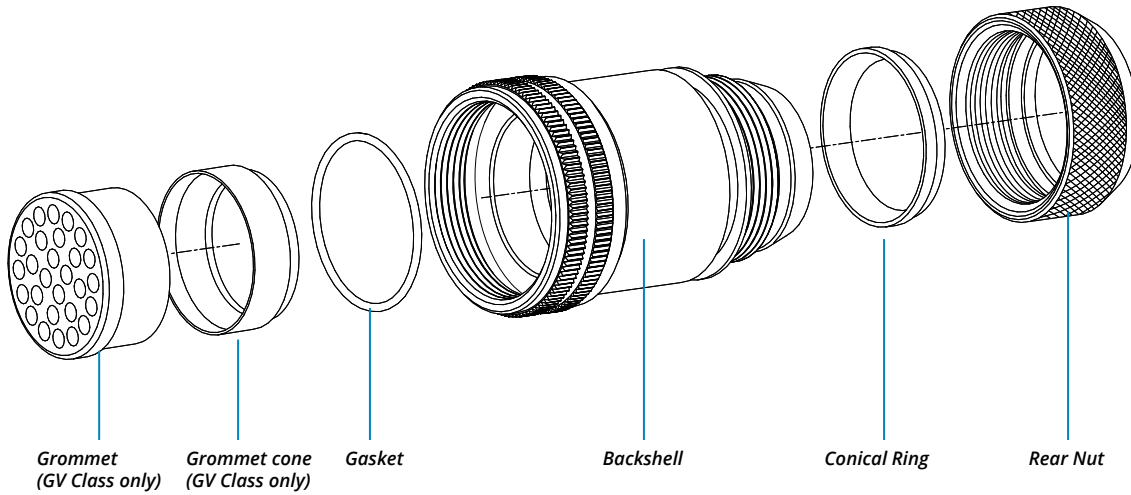

The accessories for this class are not always available in stock for all sizes; we suggest you consult our Sales Office for availability

RF	Insulating material	-	Chloroprene rubber	S	Contact Gender	S	Socket contacts
		V	Fluoride rubber			P	Pin contacts
		S	Silicone rubber				
		RF	Fire resistant rubber				
CVBS	Series Code	CVBS	Bayonet Connector with protected mating ramps	X	Polarization Code**		Alternate Positions
[]	Shell Material	-	Aluminum	CR	Contact Termination	-	Solder contacts
				CR		CR	Crimp contacts
				LC		LC	Less contacts
00	Shell Type	00	Front mounting Receptacle	CD5	Contact Plating	-	Silver plating
						CD5	Gold plating
GV	Connector Class	AGV	With waterproof O-ring (IP67***)	F7	Shell finish	F5	Electroless nickel (*)
		GV	with waterproof O-ring and grommet (IP67***)			F7	Black epoxy varnish (*)
		T	With plastic caps			F16	CCF - Black passivation (*) - conductive
		FF	Receptacle connector with threaded holes			F26	hard anodization (*)
T	Connector Modification**	-	Receptacle connector with through holes	G	Panel Gasket	-	Without gasket
			Receptacle connector with countersunk holes			G	With waterproof panel gasket
				G2		G2	With shielded panel gasket
				G3		G3	With waterproof shielded panel gasket
20-27	Insert Arrangement		Size - Type	N	Modification Code**	N	Consult our sales office
				S		S	

*** Protection degree: IP 67 (only in the mating area with mated connectors) according to EN 60529 (*) RoHS compliance (**) If required

P/N Sample: RF CVBS 00GVT 20-27SX CR CD5 F7 G N

CVBS - Bayonet Connector with protected mating ramps

Front Mounting Receptacle (00) with Backshell Class (SB)

These classes of connectors are provided with backshell for shield hose and heat shrink tubing termination. It comes complete with conical protection spring, also suitable for thin shield braid. Two piece backshell includes nut for shell tightening. Internal serration prevents backshell rotation and allows easy assembling after contacts are inserted.

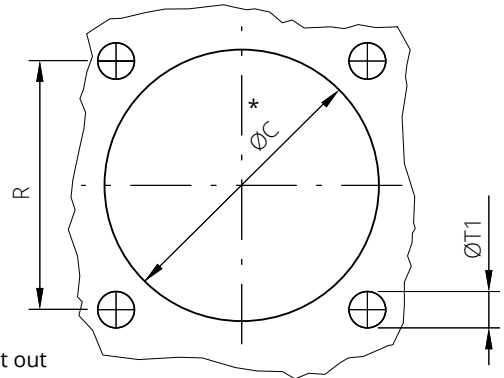

Panel cut out

* For installation with backshell mounted, consult our sales office.

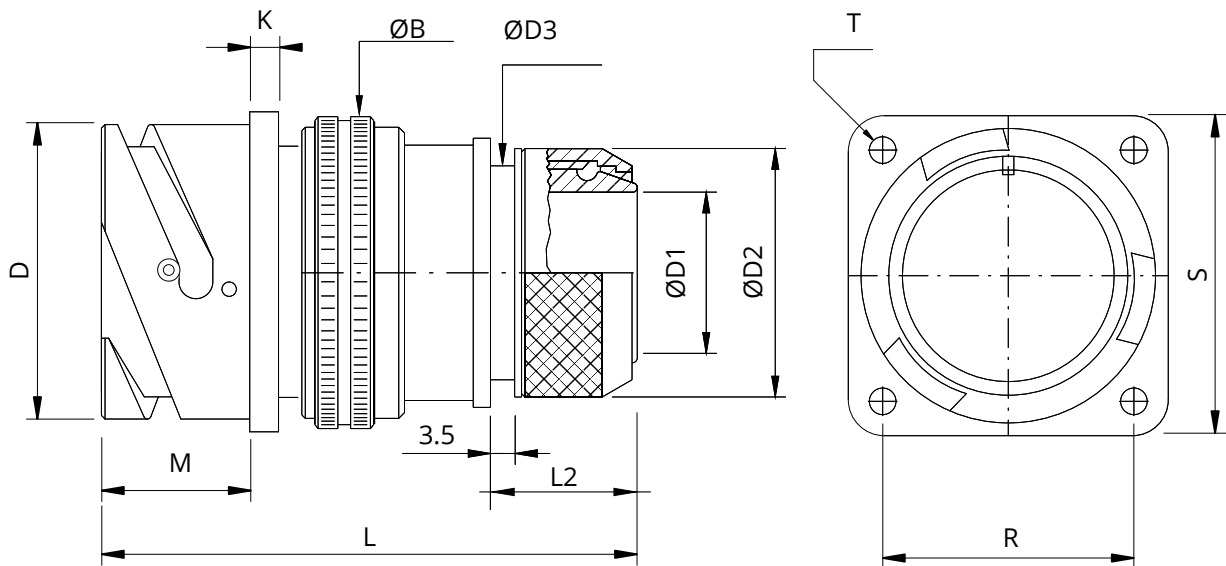

Shell size	ØD +0 -0.15	ØB ±0.2	ØD1 ±0.2	ØD2 ±0.2	ØD3 ±0.2	L	L2 ±0.2	K ±0.2	M ±0.2	R ±0.1	S ±0.3	ØT ±0.2	ØT1 Through holes	ØC* ±0.2
10SL	18.2	22.5	8.6	18.5	16.3	60	18	2.8	14.2	18.2	25.4	3.1	3.4	17
14S	24.6	26.1	10.6	22	20	60	17.6	3.2	14.5	23	30.2	3.1	3.4	20
16S	27.4	29	10.4	25	23	60	20.7	3.2	14.2	24.6	32.5	3.1	3.4	23
16	27.4	29	13.5	25	23	65	20.8	3.2	19	24.6	32.5	3.1	3.4	23
18	30.8	33.5	14.5	28	24.5	69	20.8	4	19	27	34.9	3.1	3.4	26.5
20	34.2	37	18.4	32	28.5	70	20.8	4	19	29.4	38.1	3.1	3.4	30
22	37.4	41	20.7	34	30.5	70	20.8	4	19.7	31.8	41	3.1	3.4	33
24	40.9	46	24.6	38.5	34.5	73	20.7	4	20.6	34.9	44.5	3.7	3.9	36
28	46.7	51	25	40	36	74	21.8	4	20.6	39.7	50.8	3.7	3.9	42
32	53.4	58	33.3	48	44	75	20.7	4	22.2	44.5	57	4.4	4.5	48.5
36	59.6	61	38.5	55	51	75	20.7	4	22.2	49.2	63.5	4.4	4.5	55
40	65.5	69	46	62	58	75	21.8	4	22.2	55.6	69.8	4.4	4.5	61

Dimensions in mm

Dimension "L" can be different from the value indicated according to backshells accessories, wires size and some special insert configurations.

CVBS - Bayonet Connector with protected mating ramps



Series Shell Shell Connector
Code Material Type Class

Shell
finish

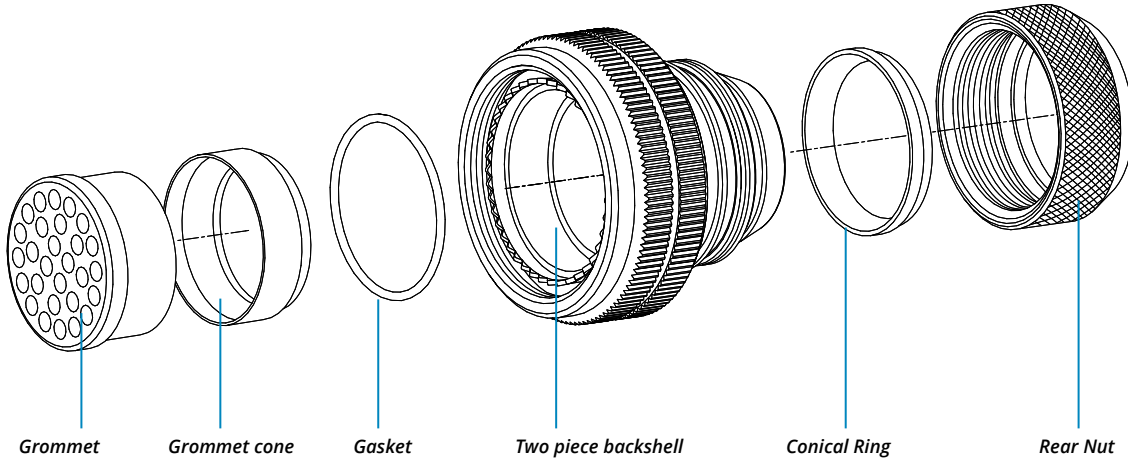

The accessories for this class are not always available in stock for all sizes; we suggest you consult our Sales Office for availability

RF	Insulating material	-	Chloroprene rubber	S	Contact Gender	S	Socket contacts
		V	Fluoride rubber			P	Pin contacts
		S	Silicone rubber				
		RF	Fire resistant rubber				
CVBS	Series Code	CVBS	Bayonet Connector with protected mating ramps	X	Polarization Code**		Alternate Positions
[]	Shell Material	-	Aluminum	CR	Contact Termination	-	Solder contacts
						CR	Crimp contacts
						LC	Less contacts
00	Shell Type	00	Front mounting Receptacle	CD5	Contact Plating	-	Silver plating
						CD5	Gold plating
SB	Connector Class	SB	With waterproof O-ring and grommet (IP67***)#	F7	Shell finish	F5	Electroless nickel (*)
		T	With plastic caps			F7	Black epoxy varnish (*)
		FF	Receptacle connector with threaded holes			F16	CCF - Black passivation (*) - conductive
		-	Receptacle connector with through holes			F26	hard anodization (*)
T	Connector Modification**	-	Receptacle connector with countersunk holes	G	Panel Gasket	-	Without gasket
						G	With waterproof panel gasket
						G2	With shielded panel gasket
						G3	With waterproof shielded panel gasket
20-27	Insert Arrangement		Size - Type	N	Modification Code**	N	Consult our sales office
						S	

*** Protection degree: IP 67 (only in the mating area with mated connectors) according to EN 60529 (*) RoHS compliance (***) If required

P/N Sample: RF CVBS 00SBT 20-27SX CR CD5 F7 G N

(#) In some sizes the grommet cone is not needed

CVBS - Bayonet Connector with protected mating ramps

Front Mounting Receptacle (020) without Accessories (To be purchased separately)

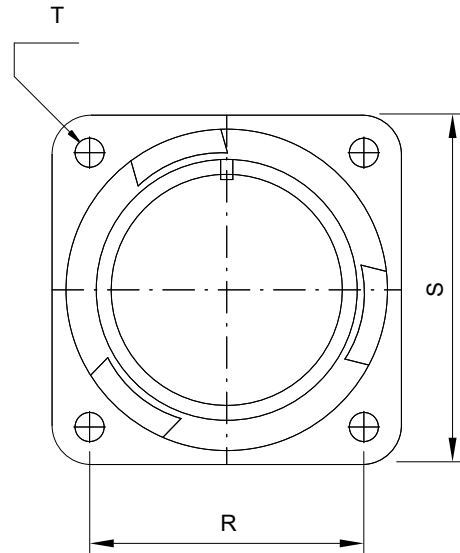
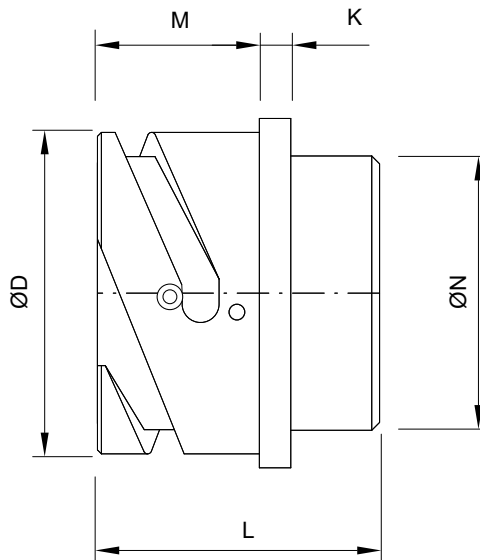
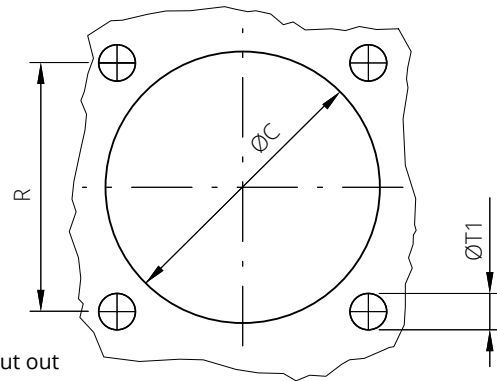

Shell size	ØD +0 -0.15	L	K ±0.2	M ±0.2	ØN Thread in inches	R ±0.1	S ±0.3	ØT ±0.2	ØT1 Through holes	ØC ±0.2
10SL	18.2	24.6	2.8	14.2	5/8"-24 UNEF	18.2	25.4	3.1	3.4	17
14S	24.6	24.6	3.2	14.5	3/4"-20 UNEF	23	30.2	3.1	3.4	20
16S	27.4	24.6	3.2	14.2	7/8"-20 UNEF	24.6	32.5	3.1	3.4	23
16	27.4	34.1	3.2	19	7/8"-20 UNEF	24.6	32.5	3.1	3.4	23
18	30.8	34.1	4	19	1"-20 UNEF	27	34.9	3.1	3.4	26.5
20	34.2	34.3	4	19	1" 1/8-18 UNEF	29.4	38.1	3.1	3.4	30
22	37.4	34.3	4	19.7	1" 1/4-18 UNEF	31.8	41	3.1	3.4	33
24	40.9	35.8	4	20.6	1" 3/8-18 UNEF	34.9	44.5	3.7	3.9	36
28	46.7	35.8	4	20.6	1" 5/8-18 UNEF	39.7	50.8	3.7	3.9	42
32	53.4	37.6	4	22.2	1" 7/8-16 UN	44.5	57	4.4	4.5	48.5
36	59.6	37.6	4	22.2	2" 1/16-16 UNS	49.2	63.5	4.4	4.5	55
40	65.5	37.6	4	22.2	2" 5/16-16 UNS	55.6	69.8	4.4	4.5	61

Dimensions in mm

Dimension "L" can be different from the value indicated according to wires size and some special insert configurations.

CVBS - Bayonet Connector with protected mating ramps



Series Code Shell Material Type

Shell finish

RF	Insulating material	-	Chloroprene rubber
		V	Fluoride rubber
		S	Silicone rubber
		RF	Fire resistant rubber
CVBS	Series Code	CVBS	Bayonet Connector with protected mating ramps
	Shell Material	-	Aluminum
020	Shell Type	020	Front mounting Receptacle
	Connector Modification**	T	With plastic caps
		FF	Receptacle connector with threaded holes
		-	Receptacle connector with through holes
		FS	Receptacle connector with countersunk holes
20-27	Insert Arrangement		Size - Type
	Contact Gender	S	Socket contacts
		P	Pin contacts
X	Polarization Code**		Alternate Positions
	Contact Termination	-	Solder contacts
		CR	Crimp contacts
		LC	Less contacts
	Contact Plating	-	Silver plating
		CD5	Gold plating
	Shell finish	F5	Electroless nickel (*)
		F7	Black epoxy varnish (*)
		F16	CCF - Black passivation (*) - conductive
		F26	hard anodization (*)
	Panel Gasket	-	Without gasket
		G	With waterproof panel gasket
		G2	With shielded panel gasket
		G3	With waterproof shielded panel gasket
	Modification Code**	N	Consult our sales office
		S	

P/N Sample: RF CVBS 020T 20-27SX CR CD5 F7 G N

(*) RoHS compliance

(**) If required

CVBS - Bayonet Connector with protected mating ramps

Front Mounting Receptacle (02 - 02A - 02R) unable to Accept Rear Accessories

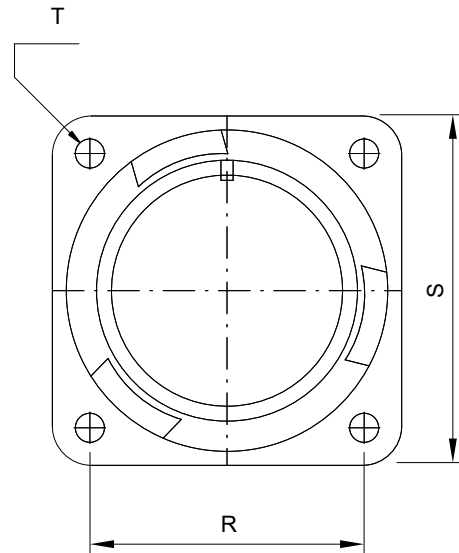
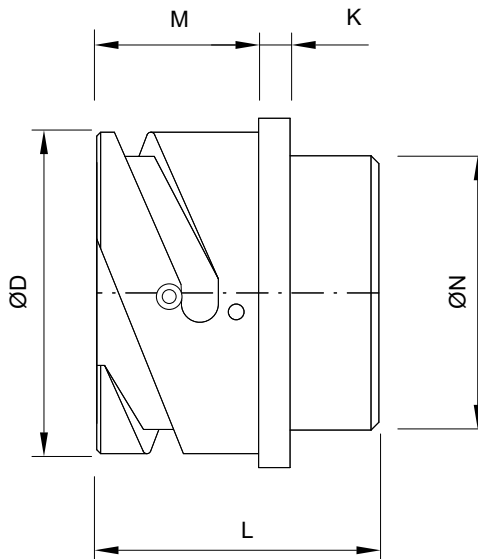
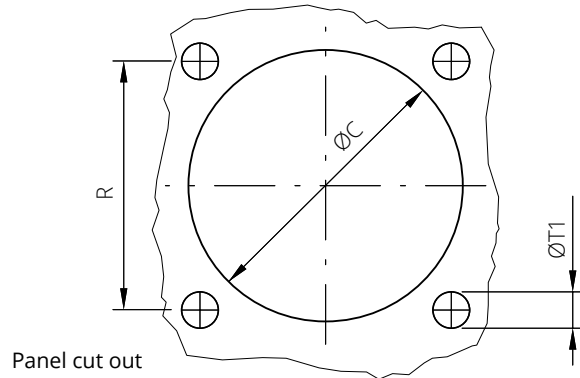

Shell size	ØD +0 -0.15	L	K ±0.2	M ±0.2	ØN Max	R ±0.1	S ±0.3	ØT ±0.2	ØT1 Through holes	ØC ±0.2
10SL	18.2	24.6	2.8	14.2	16.1	18.2	25.4	3.1	3.4	17
14S	24.6	24.6	3.2	14.5	19.2	23	30.2	3.1	3.4	20
16S	27.4	24.6	3.2	14.2	22.5	24.6	32.5	3.1	3.4	23
16	27.4	34.1	3.2	19	22.4	24.6	32.5	3.1	3.4	23
18	30.8	34.1	4	19	25.6	27	34.9	3.1	3.4	26.5
20	34.2	34.3	4	19	28.8	29.4	38.1	3.1	3.4	30
22	37.4	34.3	4	19.7	32.2	31.8	41	3.1	3.4	33
24	40.9	35.8	4	20.6	35.3	34.9	44.5	3.7	3.9	36
28	46.7	35.8	4	20.6	41.5	39.7	50.8	3.7	3.9	42
32	53.4	37.6	4	22.2	47.8	44.5	57	4.4	4.5	48.5
36	59.6	37.6	4	22.2	52.6	49.2	63.5	4.4	4.5	55
40	65.5	37.6	4	22.2	59.2	55.6	69.8	4.4	4.5	61

Dimensions in mm

Dimension "L" can be different from the value indicated according to wires size and some special insert configurations.

CVBS - Bayonet Connector with protected mating ramps

RF CVBS 02 T 20-27 S X CR CD5 F7 G N

Series Code Shell Material Type

Shell finish

RF	Insulating material	-	Chloroprene rubber
		V	Fluoride rubber
		S	Silicone rubber
		RF	Fire resistant rubber
CVBS	Series Code	CVBS	Bayonet Connector with protected mating ramps
	Shell Material	-	Aluminum
02	Shell Type	02	Front mounting receptacle connector unable to accept rear accessories (standard version)
		02A	Front mounting receptacle connector non environmental (equivalent MS3102A..B bayonet version)
		02R	Front mounting receptacle connector environmental seal (unable to accept rear accessories)
T	Connector Modification**	T	With plastic caps
		FF	Receptacle connector with threaded holes
		-	Receptacle connector with through holes
		FS	Receptacle connector with countersunk holes
20-27	Insert Arrangement		Size - Type
S	Contact Gender	S	Socket contacts
		P	Pin contacts
X	Polarization Code**		Alternate Positions
CR	Contact Termination	-	Solder contacts
		CR	Crimp contacts
		LC	Less contacts
		DS	PCB contacts
CD5	Contact Plating	-	Silver plating
		CD5	Gold plating
F7	Shell finish	F5	Electroless nickel (*)
		F7	Black epoxy varnish (*)
		F16	CCF - Black passivation (*) - conductive
		F26	hard anodization (*)
G	Panel Gasket	-	Without gasket
		G	With waterproof panel gasket
		G2	With shielded panel gasket
		G3	With waterproof shielded panel gasket
N	Modification Code**	N	
		S	Consult our sales office

P/N Sample: RF CVBS 02T 20-27SX CR CD5 F7 G N

(*) RoHS compliance

(**) If required

CVBS - Bayonet Connector with protected mating ramps

Rear Mounting Receptacle (030) without Accessories (To be purchased separately)

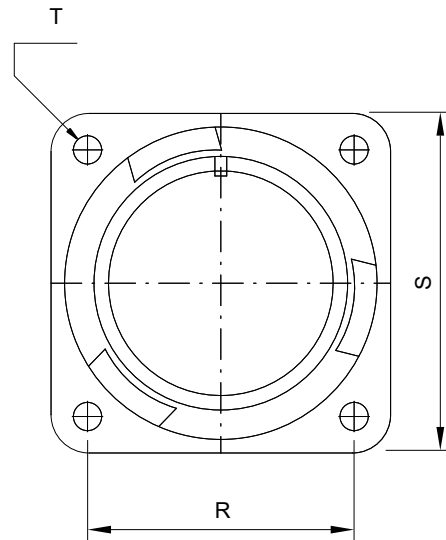
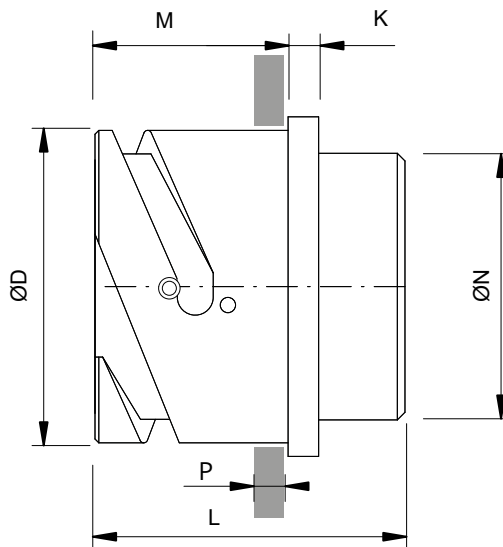
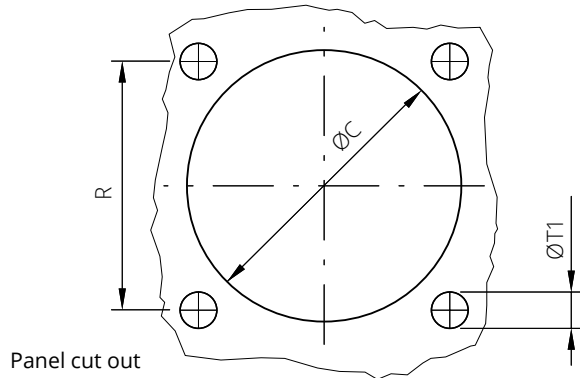

Shell size	ØD +0 -0.15	L	K ±0.2	M ±0.2	N Thread in inches	R ±0.1	S ±0.3	ØT ±0.2	ØT1 Threaded holes	ØC ±0.2	P Panel Thickness Max
10SL	18.2	30	2.8	18.2	5/8"-24 UNEF	18.2	25.4	M4	4.5	19.1	6
14S	24.6	30	3.2	18.6	3/4"-20 UNEF	23	30.2	M4	4.5	25.5	7.2
16S	27.4	30	3.2	18.6	7/8"-20 UNEF	24.6	32.5	M4	4.5	28.3	7.2
16	27.4	38.8	3.2	23.05	7/8"-20 UNEF	24.6	32.5	M4	4.5	28.3	5.35
18	30.8	38.5	4	23.4	1"-20 UNEF	27	34.9	M4	4.5	31.7	7.25
20	34.2	39.1	4	23.4	1" 1/8-18 UNEF	29.4	38.1	M4	4.5	35	7.3
22	37.4	39.3	4	23.4	1" 1/4-18 UNEF	31.8	41	M4	4.5	38.3	7.3
24	40.9	38.8	4	23.4	1" 3/8-18 UNEF	34.9	44.5	M4	4.5	41.8	6.85
28	46.7	39.1	4	24.4	1" 5/8-18 UNEF	39.7	50.8	M5	5.5	47.6	7.8
32	53.4	38.4	4	24.4	1" 7/8-16 UN	44.5	57	M5	5.5	54.3	7.5
36	59.6	39.9	4	24.4	2" 1/16-16 UNS	49.2	63.5	M5	5.5	60.5	7.5
40	65.5	38.5	4	24.4	2" 5/16-16 UNS	55.6	69.8	M5	5.5	66.4	7.5

Dimensions in mm

Dimension "L" can be different from the value indicated according to wires size and some special insert configurations.

CVBS - Bayonet Connector with protected mating ramps

RF	CVBS		030		T	20-27	S	X		CR	CD5	F7	G	N
Series Code		Shell Material Type	Shell		Shell		Shell		Shell		Shell finish		Shell	

RF	Insulating material	-	Chloroprene rubber
		V	Fluoride rubber
		S	Silicone rubber
		RF	Fire resistant rubber
CVBS	Series Code	CVBS	Bayonet Connector with protected mating ramps
	Shell Material	-	Aluminum
030	Shell Type	030	Rear mounting Receptacle
T	Connector Modification**	T	With plastic caps
		-	Receptacle connector with threaded holes
		FP	Receptacle connector with through holes
		FS	Receptacle connector with countersunk holes
20-27	Insert Arrangement		Size - Type
S	Contact Gender	S	Socket contacts
		P	Pin contacts
X	Polarization Code**		Alternate Positions
CR	Contact Termination	-	Solder contacts
		CR	Crimp contacts
		LC	Less contacts
CD5	Contact Plating	-	Silver plating
		CD5	Gold plating
F7	Shell finish	F5	Electroless nickel (*)
		F7	Black epoxy varnish (*)
		F16	CCF - Black passivation (*) - conductive
		F26	hard anodization (*)
G	Panel Gasket	-	Without gasket
		G	With waterproof panel gasket
		G2	With shielded panel gasket
		G3	With waterproof shielded panel gasket
N	Modification Code**	N	Consult our sales office
		S	

P/N Sample: RF CVBS 020T 20-27SX CR CD5 F7 G N

(*) RoHS compliance

(**) If required

CVBS - Bayonet Connector with protected mating ramps

Rear Mounting Receptacle (030) with Backshell Class (A - DA - RA)

Connector with backshell provided with an external thread suitable for MS3057...A or C type Cable-Clamps (to be ordered separately).

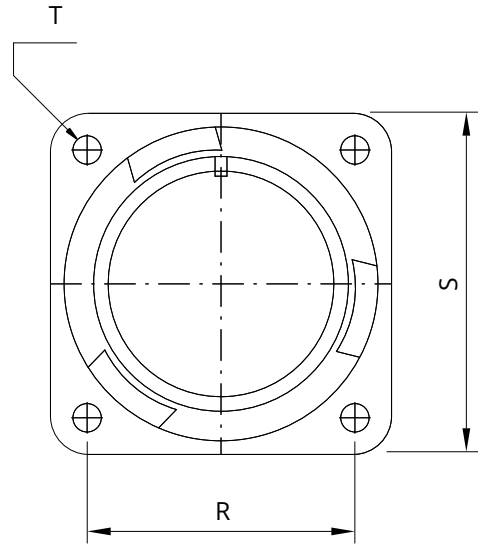
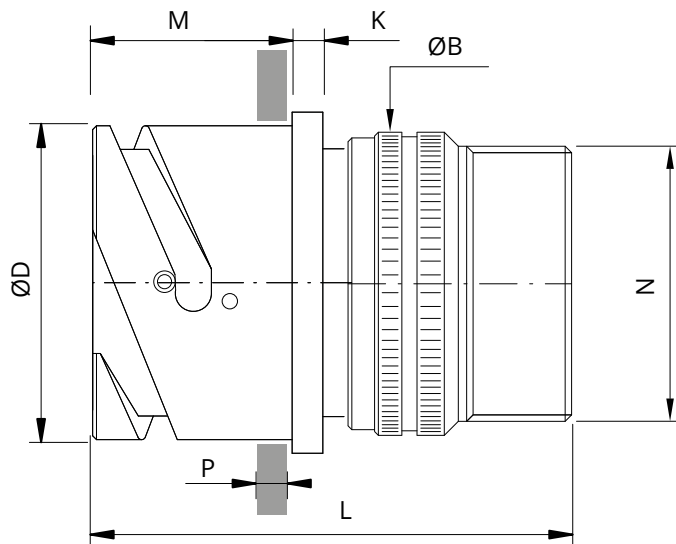
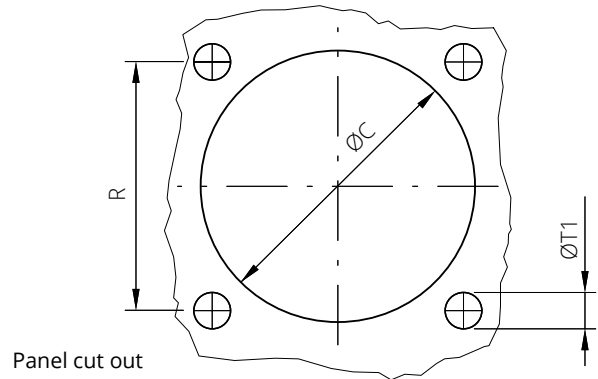

Shell size	ØD +0 -0.15	ØB ±0.2	L	M ±0.2	K ±0.2	N Backshell Thread in inches	R ±0.1	S ±0.3	ØT	ØT1	ØC ±0.2	P Panel Thickness Max
10SL	18.2	20	46	18.2	2.8	5/8"-24 UNEF	18.2	25.4	M4	4.5	19.1	6
14S	24.6	24	47.5	18.6	3.2	3/4"-20 UNEF	23	30.2	M4	4.5	25.5	7.2
16S	27.4	27	47.5	18.6	3.2	7/8"-20 UNEF	24.6	32.5	M4	4.5	28.3	7.2
16	27.4	27	54.5	23.05	3.2	7/8"-20 UNEF	24.6	32.5	M4	4.5	28.3	5.35
18	30.8	30	55.5	23.4	4	1"-20 UNEF	27	34.9	M4	4.5	31.7	7.25
20	34.2	32	55.5	23.4	4	1" 3/16-18 UNEF	29.4	38.1	M4	4.5	35	7.3
22	37.4	37	58	23.4	4	1" 3/16-18 UNEF	31.8	41	M4	4.5	38.3	7.3
24	40.9	40	58	23.4	4	1" 7/16-18 UNEF	34.9	44.5	M4	4.5	41.8	6.85
28	46.7	45	65	24.4	4	1" 7/16-18 UNEF	39.7	50.8	M5	5.5	47.6	7.8
32	53.4	52	65	24.4	4	1" 3/4-18 UNS	44.5	57	M5	5.5	54.3	7.5
36	59.6	58	65	24.4	4	2"-18 UNS	49.2	63.5	M5	5.5	60.5	7.5
40	65.5	63.2	65	24.4	4	2" 1/4-16 UN	55.6	69.8	M5	5.5	66.4	7.5

Dimensions in mm

Dimension "L" can be different from the value indicated according to backshells accessories, wires size and some special insert configurations.

CVBS - Bayonet Connector with protected mating ramps



Series Shell Shell Connector
Code Material Type Class

Shell
finish

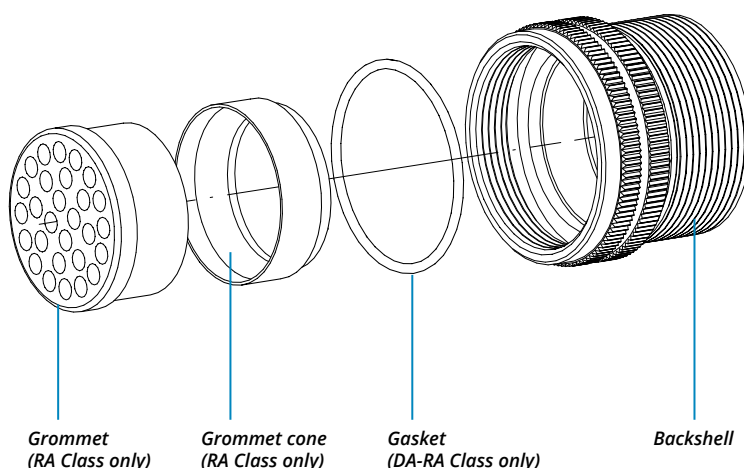

RF	Insulating material	-	Chloroprene rubber
		V	Fluoride rubber
		S	Silicone rubber
		RF	Fire resistant rubber
CVBS	Series Code	CVBS	Bayonet Connector with protected mating ramps
	Shell Material	-	Aluminum
030	Shell Type	030	Rear mounting Receptacle
DA	Connector Class	A	non watertight
		DA	with waterproof O-ring (IP67***)
		RA	with waterproof O-ring and grommet (IP67***)
T	Connector Modification**	T	With plastic caps
		-	Receptacle connector with threaded holes
		FP	Receptacle connector with through holes
		FS	Receptacle connector with countersunk holes
20-27	Insert Arrangement		Size - Type

S	Contact Gender	S	Socket contacts
		P	Pin contacts
X	Polarization Code**		Alternate Positions
CR	Contact Termination	-	Solder contacts
		CR	Crimp contacts
		LC	Less contacts
CD5	Contact Plating	-	Silver plating
		CD5	Gold plating
F7	Shell finish	F5	Electroless nickel (*)
		F7	Black epoxy varnish (*)
		F16	CCF - Black passivation (*) - conductive
		F26	hard anodization (*)
G	Panel Gasket	-	Without gasket
		G	With waterproof panel gasket
		G2	With shielded panel gasket
		G3	With waterproof shielded panel gasket
N	Modification Code**	N	Consult our sales office
		S	

*** Protection degree: IP 67 (only in the mating area with mated connectors) according to EN 60529 (*) RoHS compliance (***) If required

P/N Sample: RF CVBS 030DAT 20-27SX CR CD5 F7 G N

CVBS - Bayonet Connector with protected mating ramps

Rear Mounting Receptacle (030) with Backshell Class (AF - F)

Connector provided with backshell, MS3057...A type Cable-Clamp and bushing MS3420... (for single wire)

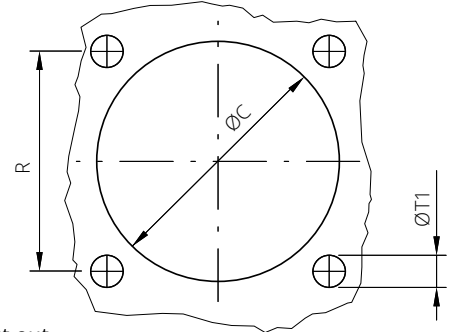

Panel cut out

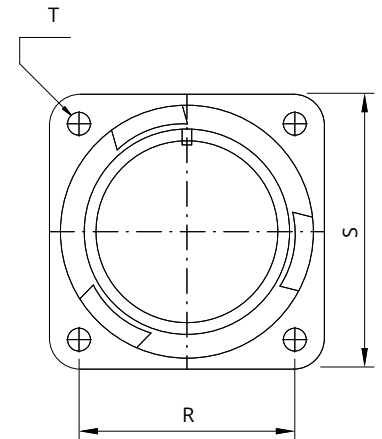
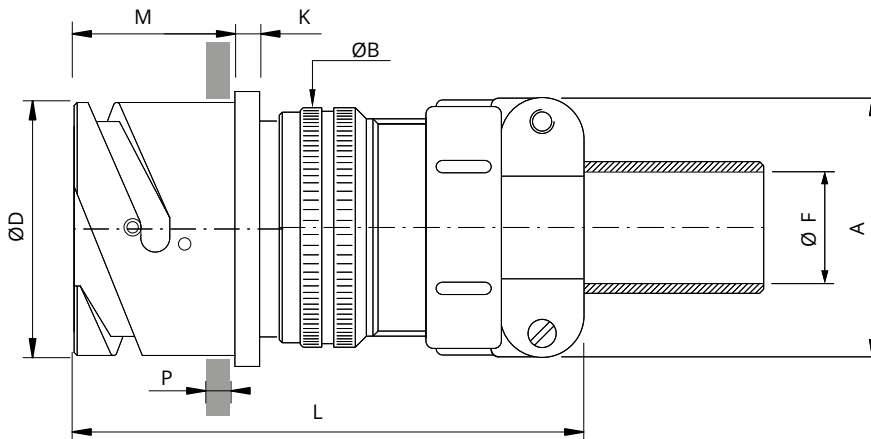

Shell size	ØD +0 -0.15	ØB ±0.2	L	M ±0.2	K ±0.2	A max	ØF cable max dimension	R ±0.1	S ±0.3	ØT	ØT1	ØC ±0.2	P Panel Thickness Max
10SL	18.2	20	56	18.2	2.8	22.5	5.6	18.2	25.4	M4	4.5	19.1	6
14S	24.6	24	59.5	18.6	3.2	28	7.9	23	30.2	M4	4.5	25.5	7.2
16S	27.4	27	61	18.6	3.2	30	11	24.6	32.5	M4	4.5	28.3	7.2
16	27.4	27	68	23.05	3.2	30	11	24.6	32.5	M4	4.5	28.3	5.35
18	30.8	30	71	23.4	4	31.7	14.2	27	34.9	M4	4.5	31.7	7.25
20	34.2	32	71	23.4	4	37.5	15.8	29.4	38.1	M4	4.5	35	7.3
22	37.4	37	73.5	23.4	4	37.5	15.8	31.8	41	M4	4.5	38.3	7.3
24	40.9	40	73.5	23.4	4	43.5	19	34.9	44.5	M4	4.5	41.8	6.85
28	46.7	45	80.5	24.4	4	43.5	19	39.7	50.8	M5	5.5	47.6	7.8
32	53.4	52	80.5	24.4	4	51.7	23.8	44.5	57	M5	5.5	54.3	7.5
36	59.6	58	81	24.4	4	58.5	31.7	49.2	63.5	M5	5.5	60.5	7.5
40	65.5	63.2	94	24.4	4	68.5	34.9	55.6	69.8	M5	5.5	66.4	7.5

Dimensions in mm

Dimension "L" can be different from the value indicated according to backshells accessories, wires size and some special insert configurations.

CVBS - Bayonet Connector with protected mating ramps



Series Code: CVBS
Shell Material: 030
Shell Type: AF
Connector Class: T

Shell finish: F7
Panel Gasket: G
Modification Code: N

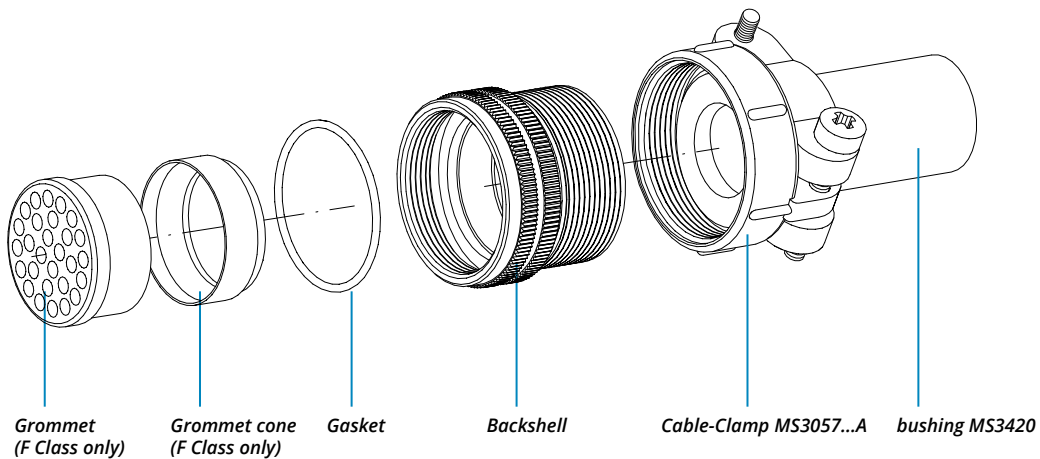

RF	Insulating material	-	Chloroprene rubber
		V	Fluoride rubber
		S	Silicone rubber
		RF	Fire resistant rubber
CVBS	Series Code	CVBS	Bayonet Connector with protected mating ramps
	Shell Material	-	Aluminum
030	Shell Type	030	Rear mounting Receptacle
AF	Connector Class	F	with waterproof O-ring and grommet (IP54)
		AF	with waterproof O-ring (IP54)
		T	With plastic caps
		-	Receptacle connector with threaded holes
T	Connector Modification**	FP	Receptacle connector with through holes
		FS	Receptacle connector with countersunk holes
20-27	Insert Arrangement		Size - Type

S	Contact Gender	S	Socket contacts
		P	Pin contacts
X	Polarization Code**		Alternate Positions
CR	Contact Termination	-	Solder contacts
		CR	Crimp contacts
		LC	Less contacts
CD5	Contact Plating	-	Silver plating
		CD5	Gold plating
F7	Shell finish	F5	Electroless nickel (*)
		F7	Black epoxy varnish (*)
		F16	CCF - Black passivation (*) - conductive
		F26	hard anodization (*)
		-	Without gasket
G	Panel Gasket	G	With waterproof panel gasket
		G2	With shielded panel gasket
		G3	With waterproof shielded panel gasket
N	Modification Code**	N	
		S	Consult our sales office

P/N Sample: RF CVBS 030AFT 20-27SX CR CD5 F7 G N

(*) RoHS compliance

(**) If required

CVBS - Bayonet Connector with protected mating ramps

Rear Mounting Receptacle (030) with Backshell Class (AC - ACF)

Connector provided with backshell, MS3057...C type Cable-Clamp (for jacketed cable)

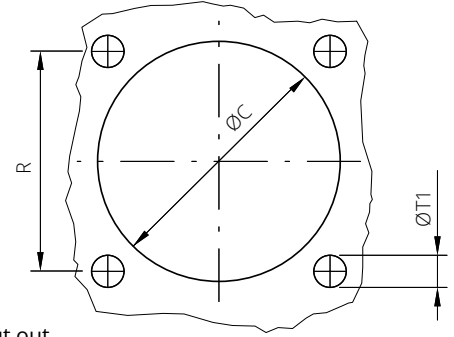

Panel cut out

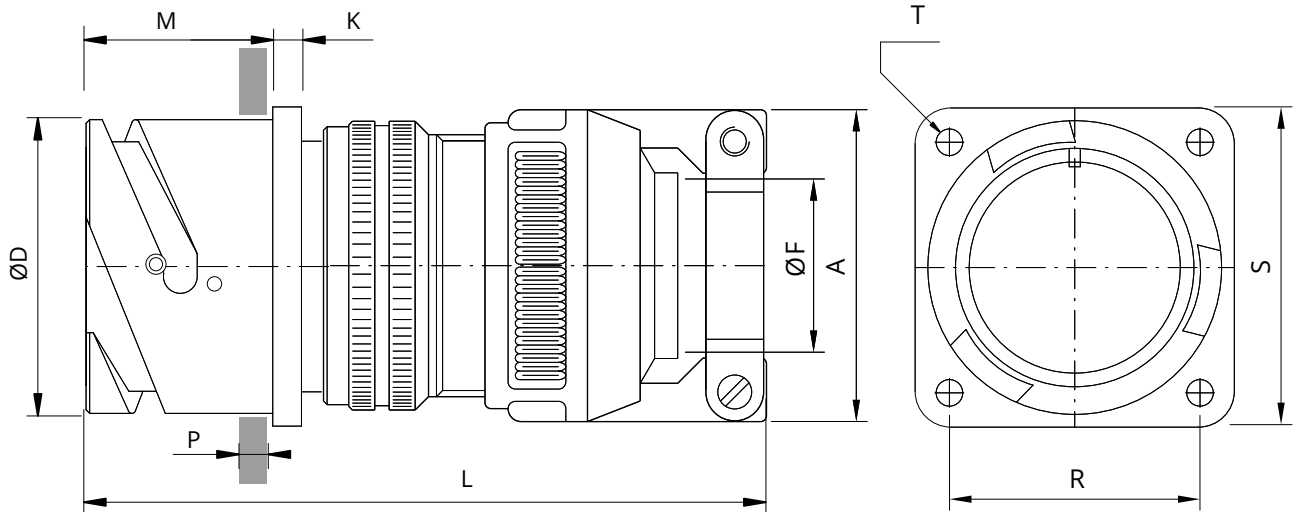

Shell size	ØD +0 -0.15	ØB ±0.2	L	K ±0.2	M ±0.2	A ±0.2	ØF cable dimension		R ±0.1	S ±0.3	ØT	ØT1	ØC ±0.2	P Panel Thickness Max
							Min	Max						
10SL	18.2	20	70	2.8	18.2	23	2.4	7.9	18.2	25.4	M4	4.5	19.1	6
14S	24.6	24	71.5	3.2	18.6	26	5.8	11.2	23	30.2	M4	4.5	25.5	7.2
16S	27.4	27	72.5	3.2	18.6	28.5	8	13.5	24.6	32.5	M4	4.5	28.3	7.2
16	27.4	27	79.5	3.2	23.05	28.5	8	13.5	24.6	32.5	M4	4.5	28.3	5.35
18	30.8	30	83	4	23.4	32	9.6	15.9	27	34.9	M4	4.5	31.7	7.25
20	34.2	32	83	4	23.4	37.5	11.3	19	29.4	38.1	M4	4.5	35	7.3
22	37.4	37	84.5	4	23.4	37.5	11.3	19	31.8	41	M4	4.5	38.3	7.3
24	40.9	40	91.5	4	23.4	43.5	15.5	23.8	34.9	44.5	M4	4.5	41.8	6.85
28	46.7	45	98.5	4	24.4	43.5	15.5	23.8	39.7	50.8	M5	5.5	47.6	7.8
32	53.4	52	103	4	24.4	54	23.4	31.8	44.5	57	M5	5.5	54.3	7.5
36	59.6	58	107.5	4	24.4	58	25.4	35	49.2	63.5	M5	5.5	60.5	7.5
40	65.5	63.2	109	4	24.4	63.5	30	41.3	55.6	69.8	M5	5.5	66.4	7.5

Dimensions in mm

Dimension "L" can be different from the value indicated according to backshells accessories, wires size and some special insert configurations.

CVBS - Bayonet Connector with protected mating ramps



Series Shell Shell Connector
Code Material Type Class

Shell
finish

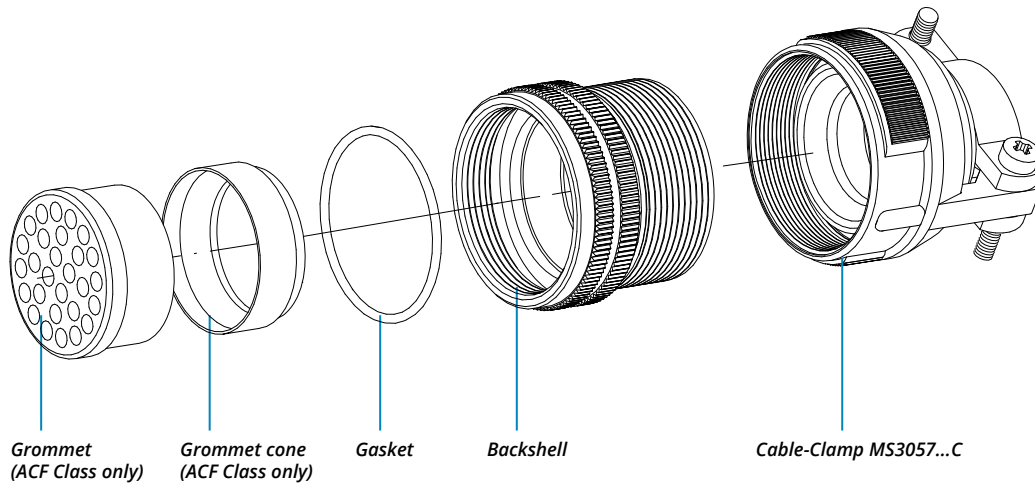

RF	Insulating material	-	Chloroprene rubber
		V	Fluoride rubber
		S	Silicone rubber
		RF	Fire resistant rubber
CVBS	Series Code	CVBS	Bayonet Connector with protected mating ramps
[]	Shell Material	-	Aluminum
030	Shell Type	030	Rear mounting Receptacle
AC	Connector Class	ACF	with waterproof O-ring and grommet (IP67)
		AC	with waterproof O-ring (IP67)
		T	With plastic caps
		-	Receptacle connector with threaded holes
T	Connector Modification**	FP	Receptacle connector with through holes
		FS	Receptacle connector with countersunk holes
20-27	Insert Arrangement		Size - Type

S	Contact Gender	S	Socket contacts
		P	Pin contacts
X	Polarization Code**		Alternate Positions
CR	Contact Termination	-	Solder contacts
		CR	Crimp contacts
		LC	Less contacts
CD5	Contact Plating	-	Silver plating
		CD5	Gold plating
F7	Shell finish	F5	Electroless nickel (*)
		F7	Black epoxy varnish (*)
		F16	CCF - Black passivation (*) - conductive
		F26	hard anodization (*)
		-	Without gasket
G	Panel Gasket	G	With waterproof panel gasket
		G2	With shielded panel gasket
		G3	With waterproof shielded panel gasket
N	Modification Code**	N	
		S	Consult our sales office

P/N Sample: RF CVBS 030ACT 20-27SX CR CD5 F7 G N

(*) RoHS compliance

(**) If required

CVBS - Bayonet Connector with protected mating ramps

Rear Mounting Receptacle (030) with Backshell Class (DA..M - RA..M)

Connector with backshell provided with an internal Metric thread suitable for Cable Glands or conduit adapters.

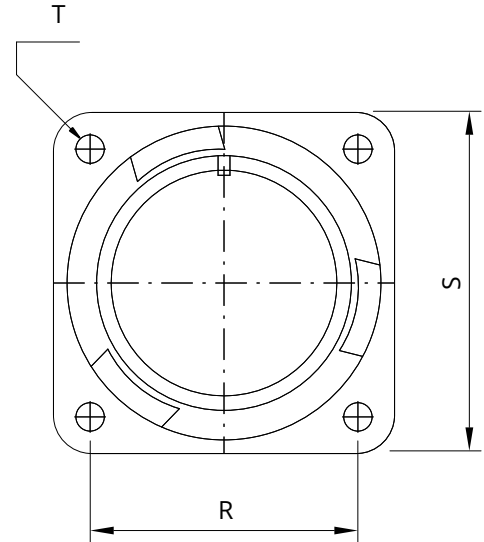
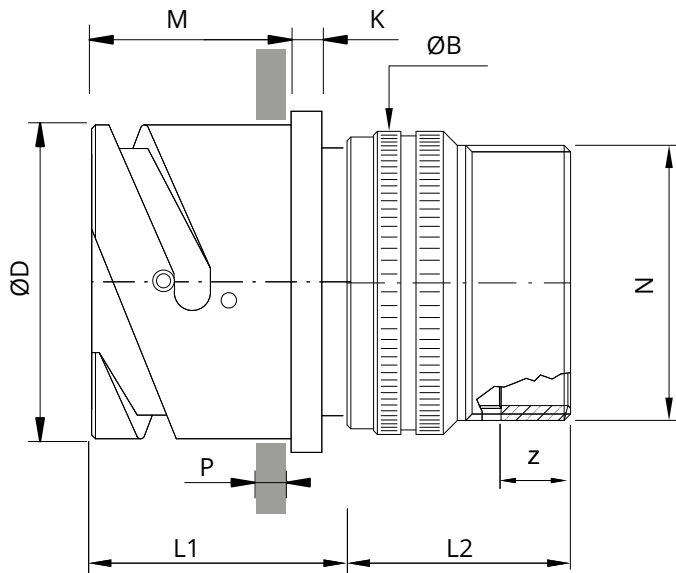
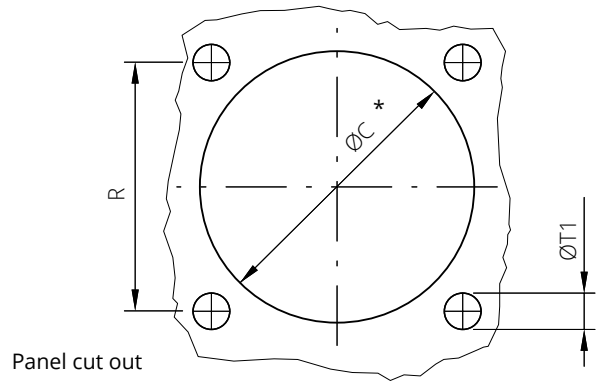

Shell size	ØD +0 -0.15	ØB ±0.2	M ±0.2	K ±0.2	Z min	L1	N Backshell Metric thread	L2 M	R ±0.1	S ±0.3	ØT	ØT1	ØC ±0.2	P Panel Thickness Max
10SL	18.2	20	18.2	2.8	8	23,3	M12 - M16	32	18.2	25.4	M4	4.5	19.1	6
14S	24.6	24	18.6	3.2	9	24,3	M12 - M16 - (M20) - (M25)	30	23	30.2	M4	4.5	25.5	7.2
16S	27.4	27	18.6	3.2	9	23,9	(M16) - M20	40	24.6	32.5	M4	4.5	28.3	7.2
16	27.4	27	23.05	3.2	9	19,4	M20	45	24.6	32.5	M4	4.5	28.3	5.35
18	30.8	30	23.4	4	9	28,2	M20 - M25	50	27	34.9	M4	4.5	31.7	7.25
20	34.2	32	23.4	4	9	29,05	M16 - M20 - M25 - (M32)	50	29.4	38.1	M4	4.5	35	7.3
22	37.4	37	23.4	4	10	29,45	M16 - M20 - M25 - M32	50	31.8	41	M4	4.5	38.3	7.3
24	40.9	40	23.4	4	10	28,6	M20 - M25 - M32 - M40	50	34.9	44.5	M4	4.5	41.8	6.85
28	46.7	45	24.4	4	10	29,3	(M25) - M32 - M40	63	39.7	50.8	M5	5.5	47.6	7.8
32	53.4	52	24.4	4	10	28,7	(M25) - (M32) - M40	55	44.5	57	M5	5.5	54.3	7.5
36	59.6	58	24.4	4	13	31	M40 - M50	56	49.2	63.5	M5	5.5	60.5	7.5
40	65.5	63.2	24.4	4	13	28,6	M40 - (M50) - M63	65	55.6	69.8	M5	5.5	66.4	7.5

Dimensions in mm

Dimensions "L1 and L2" can be different from the value indicated according to backshells accessories, wires size and some special insert configurations.

(...) The threads in parentheses are versions on request with non standard backshell length (the dimensions L2 and Z are different from this page indication). Please consult our sales office for the specific dimensions.

CVBS - Bayonet Connector with protected mating ramps



Series Code **Shell Material Type** **Shell Type** **Connector Class**

Backshell internal thread

Shell finish

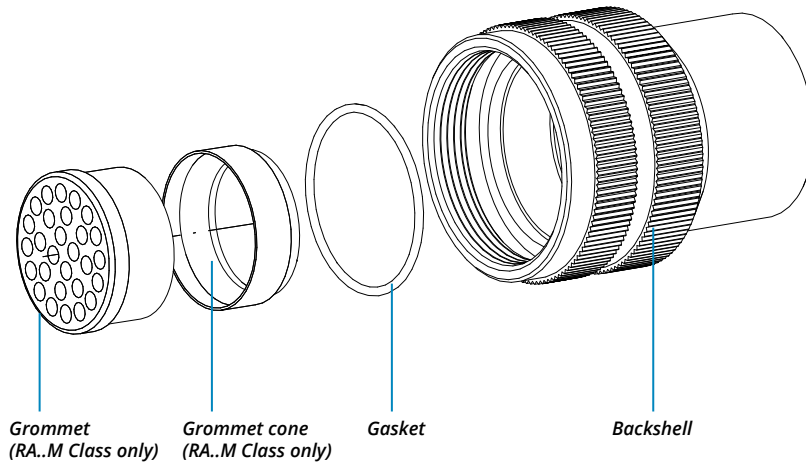

RF	Insulating material	-	Chloroprene rubber
		V	Fluoride rubber
		S	Silicone rubber
		RF	Fire resistant rubber
CVBS	Series Code	CVBS	Bayonet Connector with protected mating ramps
	Shell Material	-	Aluminum
030	Shell Type	030	Rear mounting Receptacle
DA	Connector Class	DA	with waterproof O-ring (IP67***)
		RA	with waterproof O-ring and grommet (IP67***)
T	Connector Modification**	T	With plastic caps
		-	Receptacle connector with threaded holes
		FP	Receptacle connector with through holes
		FS	Receptacle connector with countersunk holes
20-27	Insert Arrangement		Size - Type

S	Contact Gender	S	Socket contacts
		P	Pin contacts
X	Polarization Code**		Alternate Positions
M12	Backshell internal thread	M	Provided with an internal Metric thread
CR	Contact Termination	-	Solder contacts
		CR	Crimp contacts
		LC	Less contacts
CD5	Contact Plating	-	Silver plating
		CD5	Gold plating
F7	Shell finish	F5	Electroless nickel (*)
		F7	Black epoxy varnish (*)
		F16	CCF - Black passivation (*) - conductive
		F26	hard anodization (*)
		-	Without gasket
G	Panel Gasket	G	With waterproof panel gasket
		G2	With shielded panel gasket
		G3	With waterproof shielded panel gasket
N	Modification Code**	N	
		S	Consult our sales office

*** Protection degree: IP 67 (only in the mating area with mated connectors) according to EN 60529 (*) RoHS compliance (**) If required

P/N Sample: RF CVBS 030DAT 20-27SX M12 CR CD5 F7 G N

CVBS - Bayonet Connector with protected mating ramps

Rear Mounting Receptacle (030) with Backshell Class (AR - R)

This class is suitable to connect single wires when strain relief is not necessary and small longitudinal overall dimensions are needed. As watertightness is guaranteed by the grommet only, it is necessary to make sure the wire diameter matches the grommet sealing range.

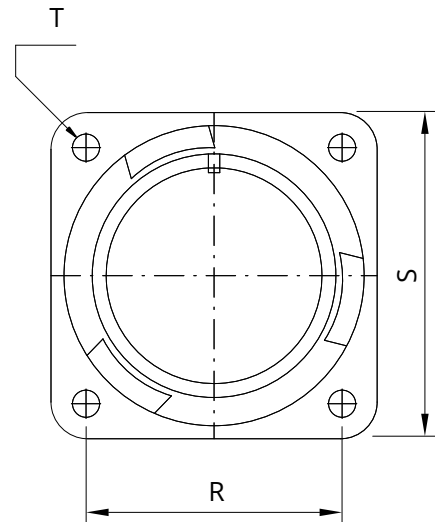
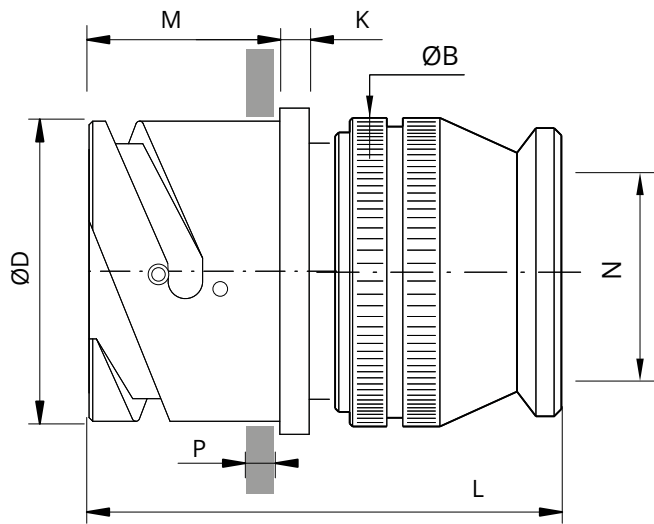
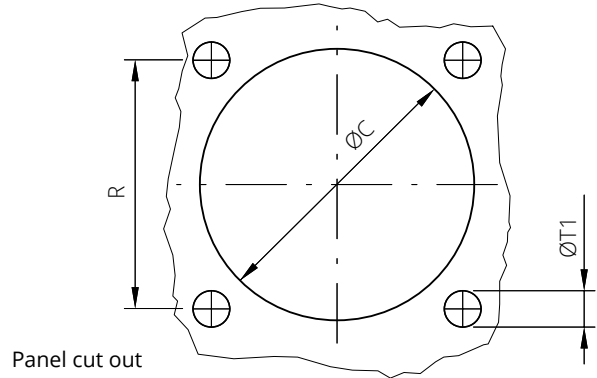

Shell size	ØD +0 -0.15	ØB ±0.2	L	K ±0.2	M ±0.2	N max cable dimension	R ±0.1	S ±0.3	ØT	ØT1	ØC ±0.2	P Panel Thickness Max
10SL	18.2	20	46	2.8	18.2	10	18.2	25.4	M4	4.5	19.1	6
14S	24.6	24	47	3.2	18.6	13.5	23	30.2	M4	4.5	25.5	7.2
16S	27.4	27	47	3.2	18.6	16.1	24.6	32.5	M4	4.5	28.3	7.2
16	27.4	27	54	3.2	23.05	16.5	24.6	32.5	M4	4.5	28.3	5.35
18	30.8	29.4	55	4	23.4	19	27	34.9	M4	4.5	31.7	7.25
20	34.2	32	55	4	23.4	22.2	29.4	38.1	M4	4.5	35	7.3
22	37.4	37	57	4	23.4	24.5	31.8	41	M4	4.5	38.3	7.3
24	40.9	40	57	4	23.4	28	34.9	44.5	M4	4.5	41.8	6.85
28	46.7	45	64	4	24.4	32.6	39.7	50.8	M5	5.5	47.6	7.8
32	53.4	52	64	4	24.4	38	44.5	57	M5	5.5	54.3	7.5
36	59.6	58	64	4	24.4	45	49.2	63.5	M5	5.5	60.5	7.5
40	65.5	63.2	64	4	24.4	51.3	55.6	69.8	M5	5.5	66.4	7.5

Dimensions in mm

Dimension "L" can be different from the value indicated according to backshells accessories, wires size and some special insert configurations.

CVBS - Bayonet Connector with protected mating ramps



Series Shell Shell Connector
Code Material Type Class

Shell
finish

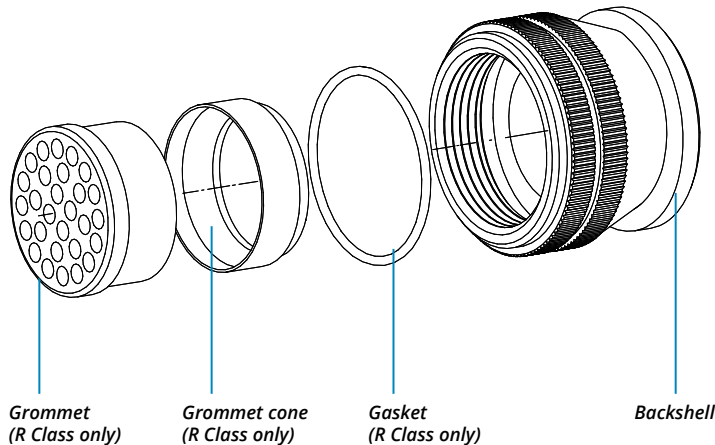

The accessories for this class are not always available in stock for all sizes; we suggest you consult our Sales Office for availability

RF	Insulating material	-	Chloroprene rubber	S	Contact Gender	S	Socket contacts
		V	Fluoride rubber			P	Pin contacts
		S	Silicone rubber				
		RF	Fire resistant rubber				
CVBS	Series Code	CVBS	Bayonet Connector with protected mating ramps	X	Polarization Code**		Alternate Positions
[empty]	Shell Material	-	Aluminum	CR	Contact Termination	-	Solder contacts
						CR	Crimp contacts
						LC	Less contacts
030	Shell Type	030	Rear mounting Receptacle	CD5	Contact Plating	-	Silver plating
						CD5	Gold plating
R	Connector Class	AR	non watertight	F7	Shell finish	F5	Electroless nickel (*)
		R	With O-ring and grommet			F7	Black epoxy varnish (*)
		T	With plastic caps			F16	CCF - Black passivation (*) - conductive
		-	Receptacle connector with threaded holes			F26	hard anodization (*)
T	Connector Modification**	-	Receptacle connector with through holes	G	Panel Gasket	-	Without gasket
		FP	Receptacle connector with through holes			G	With waterproof panel gasket
		FS	Receptacle connector with countersunk holes			G2	With shielded panel gasket
						G3	With waterproof shielded panel gasket
20-27	Insert Arrangement		Size - Type	N	Modification Code**	N	
						S	Consult our sales office

P/N Sample: RF CVBS 030RT 20-27SX CR CD5 F7 G N

(*) RoHS compliance

(**) If required

CVBS - Bayonet Connector with protected mating ramps

Rear Mounting Receptacle (030) with Backshell Class (AG - G)

These classes of connectors are all suitable for heat shrink tubing applications.

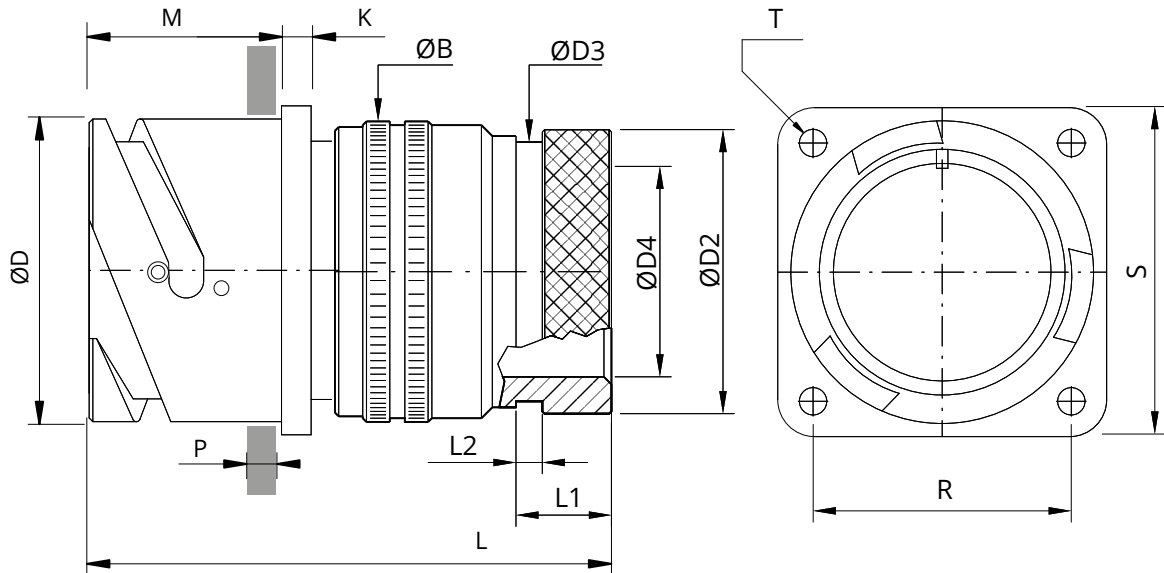
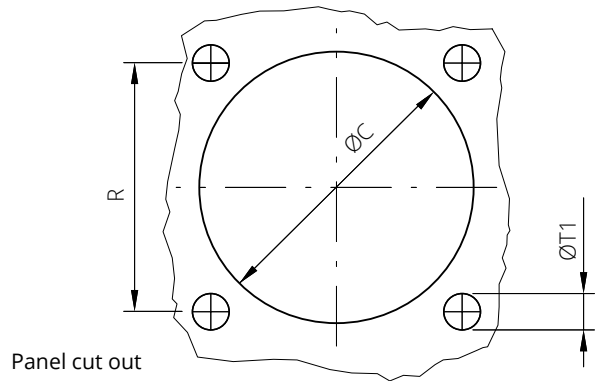

Shell size	ØD +0 -0.15	ØB ±0.2	ØD2 ±0.2	ØD3 ±0.2	ØD4 ±0.2	L	L1 ±0.2	L2 ±0.2	K ±0.2	M ±0.2	R ±0.1	S ±0.3	ØT	ØT1	ØC ±0.2	P Panel Thickness Max
10SL	18.2	20	15.5	13.3	7.9	48	11.7	3.5	2.8	18.2	18.2	25.4	M4	4.5	19.1	6
14S	24.6	24	19.1	17	13.5	48	11.7	3.5	3.2	18.6	23	30.2	M4	4.5	25.5	7.2
16S	27.4	27	23.9	21.9	13.7	48	11.7	3.5	3.2	18.6	24.6	32.5	M4	4.5	28.3	7.2
16	27.4	27	23.9	21.9	16.1	60	11.5	3.5	3.2	23.05	24.6	32.5	M4	4.5	28.3	5.35
18	30.8	30	23.9	21.9	19	65	11.5	3.5	4	23.4	27	34.9	M4	4.5	31.7	7.25
20	34.2	33	29.6	26.2	22.2	65	12.4	3.5	4	23.4	29.4	38.1	M4	4.5	35	7.3
22	37.4	37	29.6	26.2	22	65	12.7	3.5	4	23.4	31.8	41	M4	4.5	38.3	7.3
24	40.9	40	37.8	34.5	28	65	12.7	3.5	4	23.4	34.9	44.5	M4	4.5	41.8	6.85
28	46.7	45	37.8	34.5	29	65	12.7	3.5	4	24.4	39.7	50.8	M5	5.5	47.6	7.8
32	53.4	52	47.8	43.4	35.2	70	15.2	3.5	4	24.4	44.5	57	M5	5.5	54.3	7.5
36	59.6	57.2	47.7	43.4	40	75	15.2	3.5	4	24.4	49.2	63.5	M5	5.5	60.5	7.5
40	65.5	63.6	57.6	52.4	48	77	15.2	3.5	4	24.4	55.6	69.8	M5	5.5	66.4	7.5

Dimensions in mm

Dimension "L" can be different from the value indicated according to backshells accessories, wires size and some special insert configurations.

CVBS - Bayonet Connector with protected mating ramps



Series Code **Shell Material** **Shell Type** **Connector Class**

Shell finish

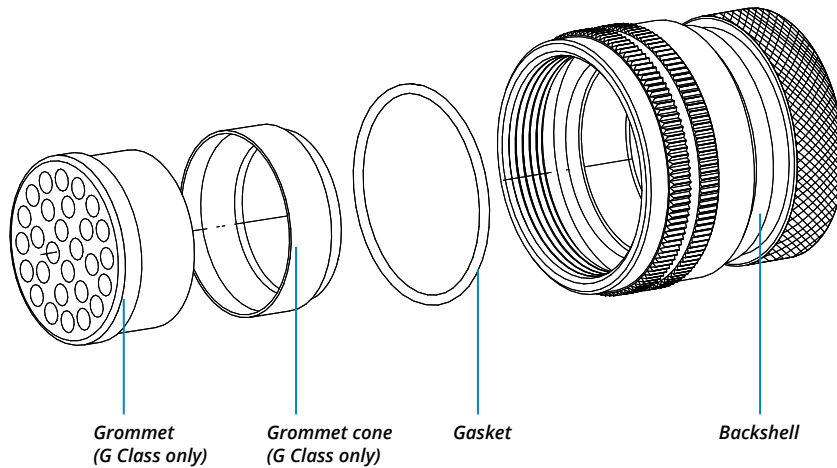

The accessories for this class are not always available in stock for all sizes; we suggest you consult our Sales Office for availability

RF	Insulating material	-	Chloroprene rubber	S	Contact Gender	S	Socket contacts
		V	Fluoride rubber			P	Pin contacts
		S	Silicone rubber				
		RF	Fire resistant rubber				
CVBS	Series Code	CVBS	Bayonet Connector with protected mating ramps	X	Polarization Code**		Alternate Positions
[empty]	Shell Material	-	Aluminum	CR	Contact Termination	-	Solder contacts
		CR	Crimp contacts			LC	Less contacts
							Silver plating
030	Shell Type	030	Rear mounting Receptacle	CD5	Contact Plating	CD5	Gold plating
AG	Connector Class	AG	With waterproof O-ring (IP67***)	F7	Shell finish	F5	Electroless nickel (*)
		G	With waterproof O-ring and grommet (IP67***)			F7	Black epoxy varnish (*)
		T	With plastic caps			F16	CCF - Black passivation (*) - conductive
T	Connector Modification**	-	Receptacle connector with threaded holes	G	Panel Gasket	F26	hard anodization (*)
		FP	Receptacle connector with through holes			-	Without gasket
		FS	Receptacle connector with countersunk holes			G	With waterproof panel gasket
20-27	Insert Arrangement		Size - Type	N	Modification Code**	G2	With shielded panel gasket
						G3	With waterproof shielded panel gasket
						N	
						S	Consult our sales office

*** Protection degree: IP 67 (only in the mating area with mated connectors) according to EN 60529 (*) RoHS compliance (***) If required

P/N Sample: RF CVBS 030AGT 20-27SX CR CD5 F7 G N

CVBS - Bayonet Connector with protected mating ramps

Rear Mounting Receptacle (030) with Backshell Class (AST - ST)

Connector with backshell with internal cable retention system (on request ST1/ST2 with clamps for cable diameter reduction) with an external unef thread

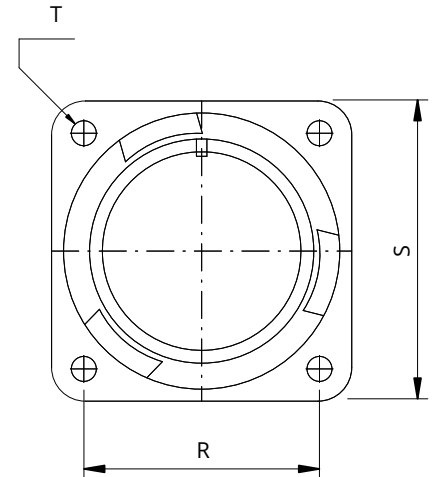
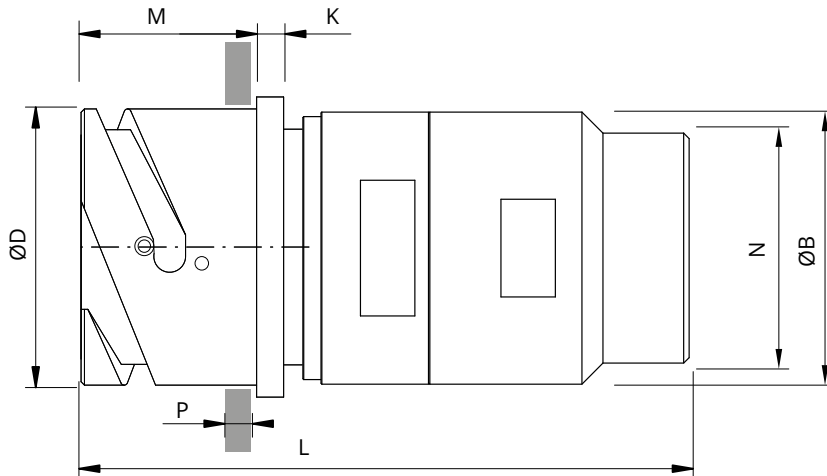
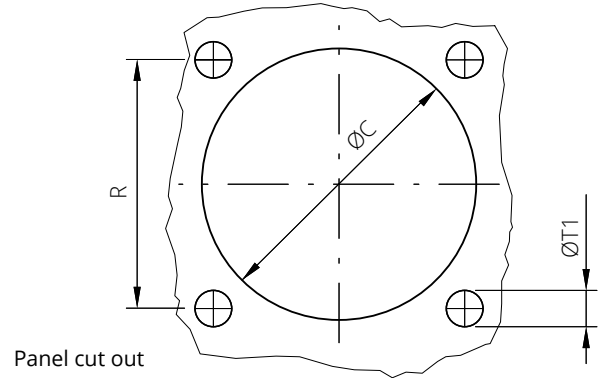

Shell size	ØD +0 -0.15	ØB ±0.2	L	M ±0.2	K ±0.2	N Backshell Thread in inches	R ±0.1	S ±0.3	ØT	ØT1	ØC ±0.2	P Panel Thickness Max	Cable Range		
													ST	ST1	ST2
18	30.8	30	95	23.4	4	1"-20 UNEF	27	34.9	M4	4.5	31.7	7.25	14-9	9-4	*
20	34.2	32	95	23.4	4	1" 3/16-18 UNEF	29.4	38.1	M4	4.5	35	7.3	19-14	14-9	*
22	37.4	38	95	23.4	4	1" 3/16-18 UNEF	31.8	41	M4	4.5	38.3	7.3	19-14	14-9	*
24	40.9	45	100	23.4	4	1" 7/16-18 UNEF	34.9	44.5	M4	4.5	41.8	6.85	23-18	18-13	*
28	46.7	48	100	24.4	4	1" 7/16-18 UNEF	39.7	50.8	M5	5.5	47.6	7.8	23-18	18-13	*
32	53.4	55	105	24.4	4	1" 3/4-18 UNS	44.5	57	M5	5.5	54.3	7.5	31-25	25-19	19-13
36	59.6	58	115	24.4	4	2"-18 UNS	49.2	63.5	M5	5.5	60.5	7.5	33-25	25-18	*
40	65.5	65	115	24.4	4	2" 1/4-16 UN	55.6	69.8	M5	5.5	66.4	7.5	39-31	31-24	24-16

Dimensions in mm

* On request (please consult our Sales Office)

Dimension "L" can be different from the value indicated according to backshells accessories, wires size and some special insert configurations.

CVBS - Bayonet Connector with protected mating ramps



Series Shell Shell Connector
Code Material Type Class

Shell
finish

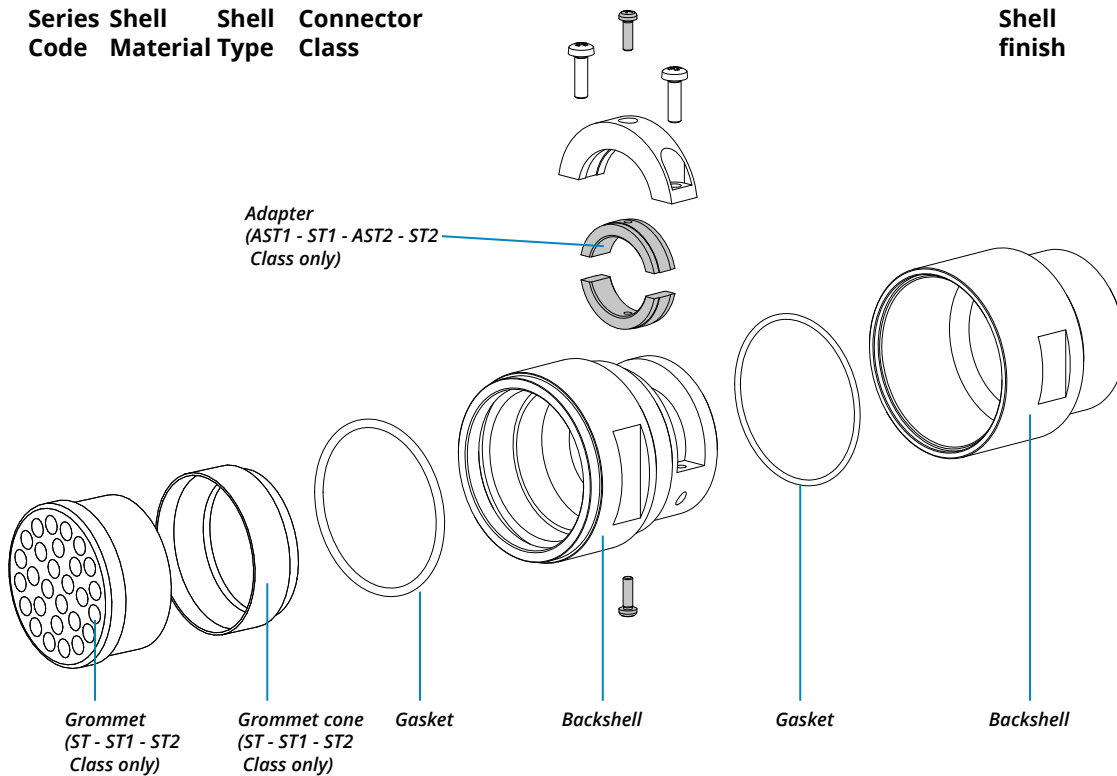

RF	Insulating material	-	Chloroprene rubber
		V	Fluoride rubber
		S	Silicone rubber
		RF	Fire resistant rubber
CVBS	Series Code	CVBS	Bayonet Connector with protected mating ramps
	Shell Material	-	Aluminum
030	Shell Type	030	Rear mounting Receptacle
		AST	with waterproof O-ring (IP67***)
		ST	with waterproof O-ring and grommet (IP67***)
ST	Connector Class	AST1	with waterproof O-ring (IP67***)
		ST1	with waterproof O-ring and grommet (IP67***)
		AST2	with waterproof O-ring (IP67***)
		ST2	with waterproof O-ring and grommet (IP67***)
		T	With plastic caps
T	Connector Modification**	-	Receptacle connector with threaded holes
		FP	Receptacle connector with through holes
		FS	Receptacle connector with countersunk holes

20-27	Insert Arrangement		Size - Type
S	Contact Gender	S	Socket contacts
		P	Pin contacts
X	Polarization Code**		Alternate Positions
		-	Solder contacts
CR	Contact Termination	CR	Crimp contacts
		LC	Less contacts
		-	Silver plating
CD5	Contact Plating	CD5	Gold plating
F7	Shell finish	F5	Electroless nickel (*)
		F7	Black epoxy varnish (*)
		F16	CCF - Black passivation (*) - conductive
		F26	hard anodization (*)
		-	Without gasket
		G	With waterproof panel gasket
G	Panel Gasket	G2	With shielded panel gasket
		G3	With waterproof shielded panel gasket
N	Modification Code**	N	
		S	Consult our sales office

*** Protection degree: IP 67 (only in the mating area with mated connectors) according to EN 60529 (*) RoHS compliance (**) If required

P/N Sample: RF CVBS 030STT 20-27SX CR CD5 F7 G N

CVBS - Bayonet Connector with protected mating ramps

Rear Mounting Receptacle (030) with Backshell Class (AST..M - ST..M)

Connector with backshell with internal cable retention system (on request ST1/ST2 with clamps for cable diameter reduction) with an internal Metric thread

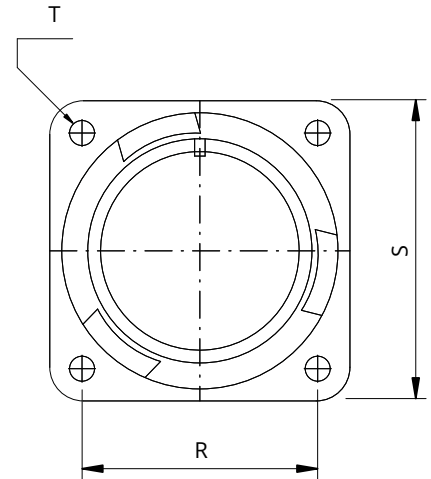
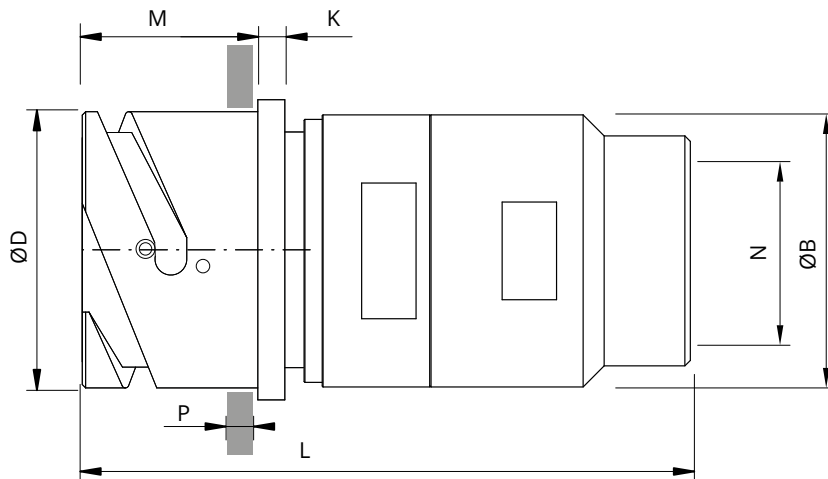
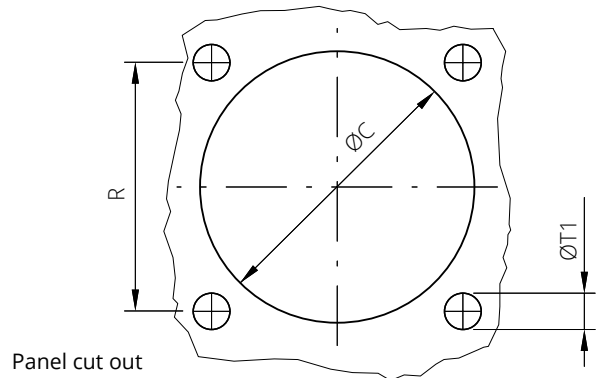

Shell size	ØD +0 -0.15	ØB ±0.2	L	M ±0.2	K ±0.2	N Backshell Thread Metric	R ±0.1	S ±0.3	ØT	ØT1	ØC ±0.2	P Panel Thickness Max	Cable Range		
													ST	ST1	ST2
18	30.8	30	95	23.4	4	M16 - M20	27	34.9	M4	4.5	31.7	7.25	14-9	9-4	*
20	34.2	32	95	23.4	4	M20	29.4	38.1	M4	4.5	35	7.3	19-14	14-9	*
22	37.4	38	95	23.4	4	M20	31.8	41	M4	4.5	38.3	7.3	19-14	14-9	*
24	40.9	45	100	23.4	4	M25	34.9	44.5	M4	4.5	41.8	6.85	23-18	18-13	*
28	46.7	48	100	24.4	4	M25	39.7	50.8	M5	5.5	47.6	7.8	23-18	18-13	*
32	53.4	55	105	24.4	4	M32 - M40	44.5	57	M5	5.5	54.3	7.5	31-25	25-19	19-13
36	59.6	58	120	24.4	4	M32 - M40	49.2	63.5	M5	5.5	60.5	7.5	33-25	25-18	*
40	65.5	65	120	24.4	4	M40 - M50	55.6	69.8	M5	5.5	66.4	7.5	39-31	31-24	24-16

Dimensions in mm

* On request (please consult our Sales Office)

Dimension "L" can be different from the value indicated according to backshells accessories, wires size and some special insert configurations.

CVBS - Bayonet Connector with protected mating ramps



Series Shell Shell Connector
Code Material Type Class

Shell
finish

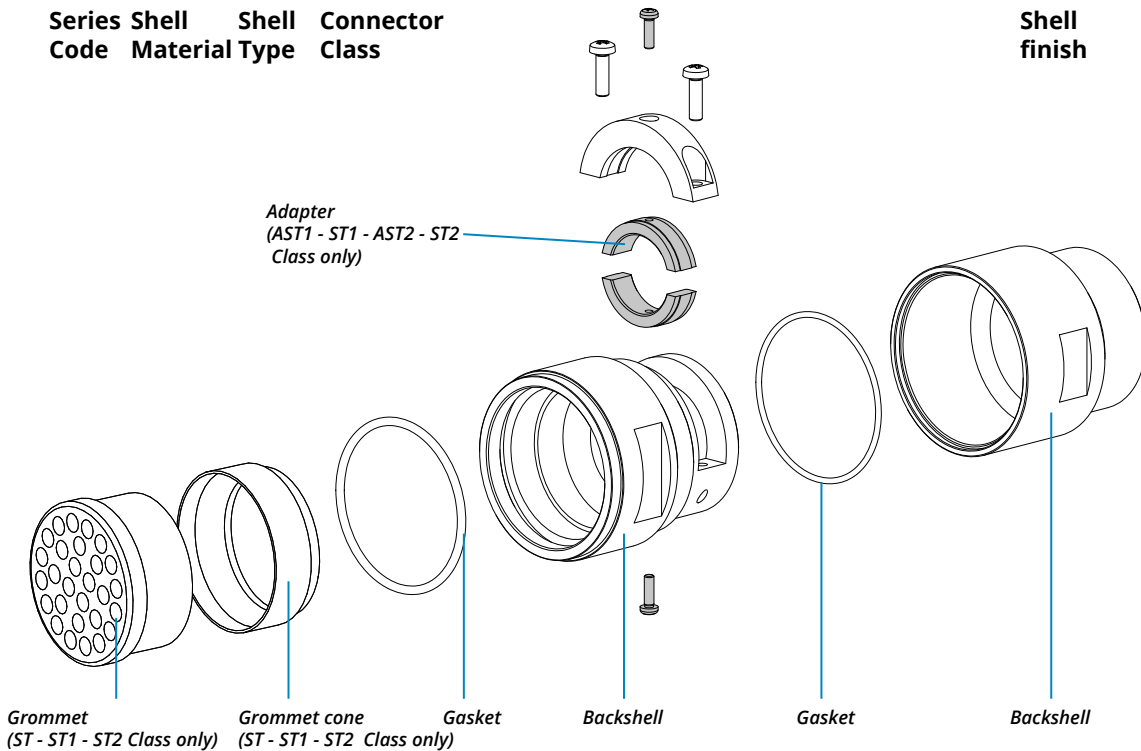

RF	Insulating material	-	Chloroprene rubber
		V	Fluoride rubber
		S	Silicone rubber
		RF	Fire resistant rubber
CVBS	Series Code	CVBS	Bayonet Connector with protected mating ramps
[]	Shell Material	-	Aluminum
030	Shell Type	030	Rear mounting Receptacle
		AST	with waterproof O-ring (IP67***)
		ST	with waterproof O-ring and grommet (IP67***)
ST	Connector Class	AST1	with waterproof O-ring (IP67***)
		ST1	with waterproof O-ring and grommet (IP67***)
		AST2	with waterproof O-ring (IP67***)
		ST2	with waterproof O-ring and grommet (IP67***)
		T	With plastic caps
T	Connector Modification**	-	Receptacle connector with threaded holes
		FP	Receptacle connector with through holes
		FS	Receptacle connector with countersunk holes
20-27	Insert Arrangement		Size - Type

S	Contact Gender	S	Socket contacts
		P	Pin contacts
X	Polarization Code**		Alternate Positions
M	Backshell internal thread	M	Provided with an internal Metric thread
CR	Contact Termination	-	Solder contacts
		CR	Crimp contacts
		LC	Less contacts
CD5	Contact Plating	-	Silver plating
		CD5	Gold plating
F7	Shell finish	F5	Electroless nickel (*)
		F7	Black epoxy varnish (*)
		F16	CCF - Black passivation (*) - conductive
		F26	hard anodization (*)
		-	Without gasket
G	Panel Gasket	G	With waterproof panel gasket
		G2	With shielded panel gasket
		G3	With waterproof shielded panel gasket
N	Modification Code**	N	
		S	Consult our sales office

*** Protection degree: IP 67 (only in the mating area with mated connectors) according to EN 60529 (*) RoHS compliance (**) If required

P/N Sample: RF CVBS 030STT 20-27SX M CR CD5 F7 G N

CVBS - Bayonet Connector with protected mating ramps

Rear Mounting Receptacle (030) with Backshell Class (AST..FS - ST..FS)

Connector with backshell with internal cable retention system (on request ST1/ST2 with clamps for cable diameter reduction) with a special adapter for rubber conduits

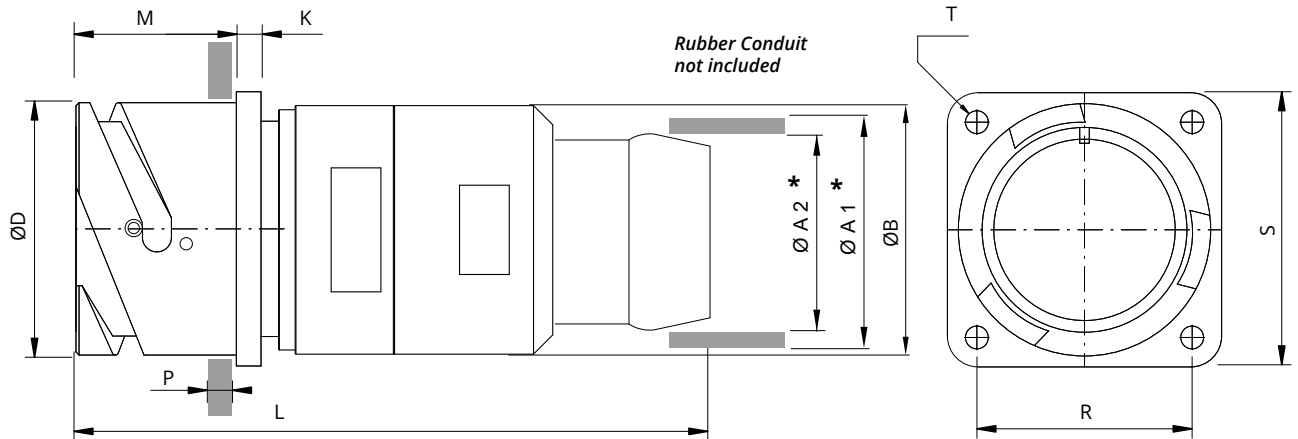
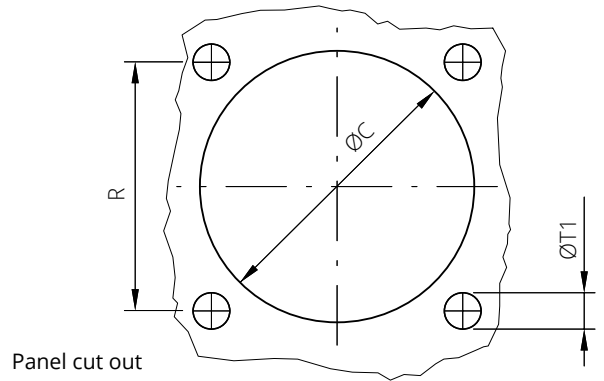

Please consult our Sales Office for further details about this dimension and according to conduit size.

Backshell Conduit Size	ØA1*	ØA2*
FS2015	20	15
FS2520	25	20
FS2722	27	22
FS3328	33	28
FS3530	35	30
FS4035	40	35
FS4540	45	40
FS5045	50	45
FS5945	59	45

Shell size	ØD +0 -0.15	ØB ±0.2	L	M ±0.2	K ±0.2	R ±0.1	S ±0.3	ØT	ØT1	ØC ±0.2	P Panel Thickness Max	Cable Range	ST	ST1	ST2
18	30.8	30	110	23.4	4	27	34.9	M4	4.5	31.7	7.25	14-9	9-4	*	
20	34.2	32	110	23.4	4	29.4	38.1	M4	4.5	35	7.3	19-14	14-9	*	
22	37.4	38	110	23.4	4	31.8	41	M4	4.5	38.3	7.3	19-14	14-9	*	
24	40.9	45	115	23.4	4	34.9	44.5	M4	4.5	41.8	6.85	23-18	18-13	*	
28	46.7	48	115	24.4	4	39.7	50.8	M5	5.5	47.6	7.8	23-18	18-13	*	
32	53.4	55	120	24.4	4	44.5	57	M5	5.5	54.3	7.5	31-25	25-19	19-13	
36	59.6	58	135	24.4	4	49.2	63.5	M5	5.5	60.5	7.5	33-25	25-18	*	
40	65.5	65	135	24.4	4	55.6	69.8	M5	5.5	66.4	7.5	39-31	31-24	24-16	

Dimensions in mm

* On request (please consult our Sales Office)

Dimension "L" can be different from the value indicated according to backshells accessories, wires size and some special insert configurations.

CVBS - Bayonet Connector with protected mating ramps

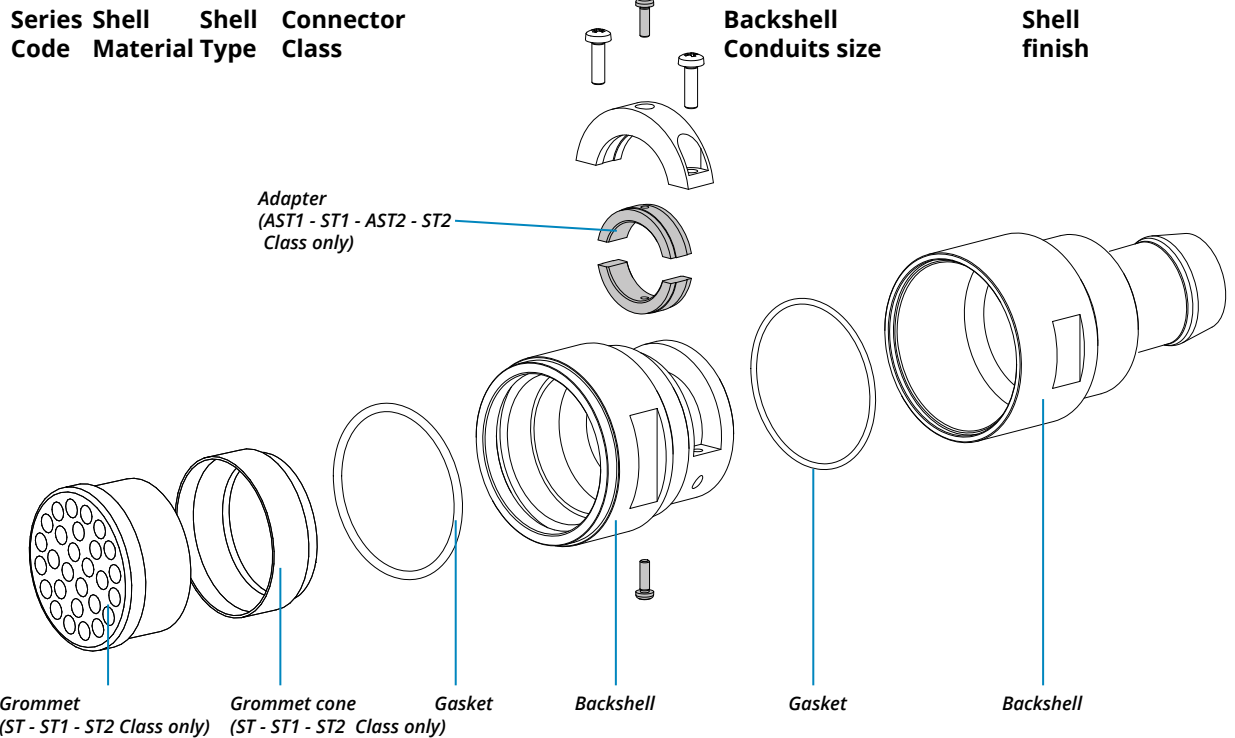

RF	Insulating material	- Chloroprene rubber V Fluoride rubber S Silicone rubber RF Fire resistant rubber	S	Contact Gender	S Socket contacts P Pin contacts
CVBS	Series Code	CVBS Bayonet Connector with protected mating ramps	X	Polarization Code**	Alternate Positions
	Shell Material	- Aluminum	FS	Backshell Conduits size	FS Provided with a special adapter for rubber conduits
030	Shell Type	030 Rear mounting Receptacle	xxxx	Conduit Size	xxxx ØA1/ØA2
ST	Connector Class	AST with waterproof O-ring (IP67***)	CR	Contact Termination	- Solder contacts
		ST with waterproof O-ring and grommet (IP67***)			CR Crimp contacts
		AST1 with waterproof O-ring (IP67***)			LC Less contacts
		ST1 with waterproof O-ring and grommet (IP67***)			- Silver plating
		AST2 with waterproof O-ring (IP67***)			CD5
T	Connector Modification**	T With plastic caps	F7	Shell finish	F5 Electroless nickel (*)
		- Receptacle connector with threaded holes			F7 Black epoxy varnish (*)
		FP Receptacle connector with through holes			F16 CCF - Black passivation (*) - conductive
20-27	Insert Arrangement	FS Receptacle connector with countersunk holes	G	Panel Gasket	F26 hard anodization (*)
					- Without gasket
					G With waterproof panel gasket
			N	Modification Code**	G2 With shielded panel gasket
					G3 With waterproof shielded panel gasket
					N
					S Consult our sales office

*** Protection degree: IP 67 (only in the mating area with mated connectors) according to EN 60529 (*) RoHS compliance (**) If required

P/N Sample: RF CVBS 030STT 20-27SX FSxxxx CR CD5 F7 G N

CVBS - Bayonet Connector with protected mating ramps

Rear Mounting Receptacle (03 - 03A - 03R) unable to accept Rear Accessories

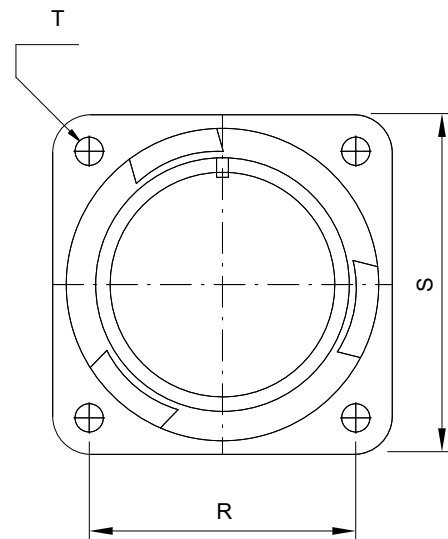
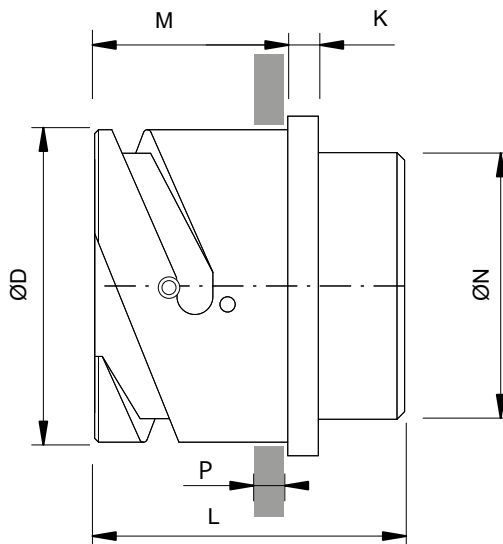
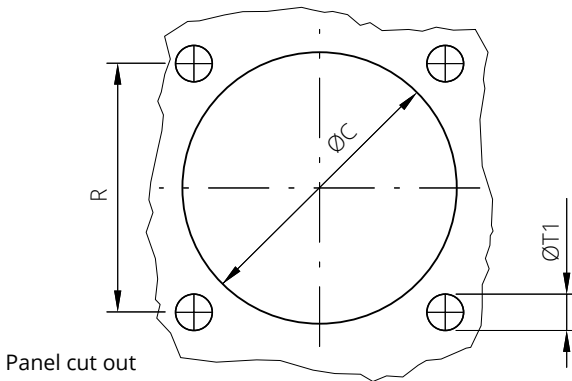

Shell size	ØD +0 -0.15	L	K ±0.2	M ±0.2	ØN Max	R ±0.1	S ±0.3	ØT	ØT1	ØC ±0.2	P Panel Thickness Max
10SL	18.2	30	2.8	18.2	16.1	18.2	25.4	M4	4.5	19.1	6
14S	24.6	30	3.2	18.6	19.2	23	30.2	M4	4.5	25.5	7.2
16S	27.4	30	3.2	18.6	22.5	24.6	32.5	M4	4.5	28.3	7.2
16	27.4	38.8	3.2	23.05	22.4	24.6	32.5	M4	4.5	28.3	5.35
18	30.8	38.5	4	23.4	25.6	27	34.9	M4	4.5	31.7	7.25
20	34.2	39.1	4	23.4	28.8	29.4	38.1	M4	4.5	35	7.3
22	37.4	39.3	4	23.4	32.2	31.8	41	M4	4.5	38.3	7.3
24	40.9	38.8	4	23.4	35.3	34.9	44.5	M4	4.5	41.8	6.85
28	46.7	39.1	4	24.4	41.5	39.7	50.8	M5	5.5	47.6	7.8
32	53.4	38.4	4	24.4	47.8	44.5	57	M5	5.5	54.3	7.5
36	59.6	39.9	4	24.4	52.6	49.2	63.5	M5	5.5	60.5	7.5
40	65.5	38.5	4	24.4	59.2	55.6	69.8	M5	5.5	66.4	7.5

Dimensions in mm

Dimension "L" can be different from the value indicated according to wires size and some special insert configurations.

CVBS - Bayonet Connector with protected mating ramps

RF CVBS 03 T 20-27 S X CR CD5 F7 G N

Series Code Shell Material Type

Shell finish

RF	Insulating material	-	Chloroprene rubber
		V	Fluoride rubber
		S	Silicone rubber
		RF	Fire resistant rubber
CVBS	Series Code	CVBS	Bayonet Connector with protected mating ramps
	Shell Material	-	Aluminum
03	Shell Type	03	Rear mounting receptacle connector unable to accept rear accessories
		03A	Rear mounting receptacle connector non environmental (equivalent MS3103A..B bayonet version)
		03R	Rear mounting receptacle connector environmental seal (unable to accept rear accessories)
T	Connector Modification**	T	With plastic caps
		-	Receptacle connector with threaded holes
		FP	Receptacle connector with through holes
		FS	Receptacle connector with countersunk holes
20-27	Insert Arrangement		Size - Type
S	Contact Gender	S	Socket contacts
		P	Pin contacts
X	Polarization Code**		Alternate Positions
CR	Contact Termination	-	Solder contacts
		CR	Crimp contacts
		LC	Less contacts
		DS	PCB contacts
CD5	Contact Plating	-	Silver plating
		CD5	Gold plating
F7	Shell finish	F5	Electroless nickel (*)
		F7	Black epoxy varnish (*)
		F16	CCF - Black passivation (*) - conductive
		F26	hard anodization (*)
G	Panel Gasket	-	Without gasket
		G	With waterproof panel gasket
		G2	With shielded panel gasket
		G3	With waterproof shielded panel gasket
N	Modification Code**	N	
		S	Consult our sales office

P/N Sample: RF CVBS 03T 20-27SX CR CD5 F7 G N

(*) RoHS compliance

(**) If required

CVBS - Bayonet Connector with protected mating ramps

In-Line Receptacle (01) with Backshell Class (A - DA - RA)

Connector with backshell provided with an external thread suitable for MS3057...A or C type Cable-Clamps (to be ordered separately).

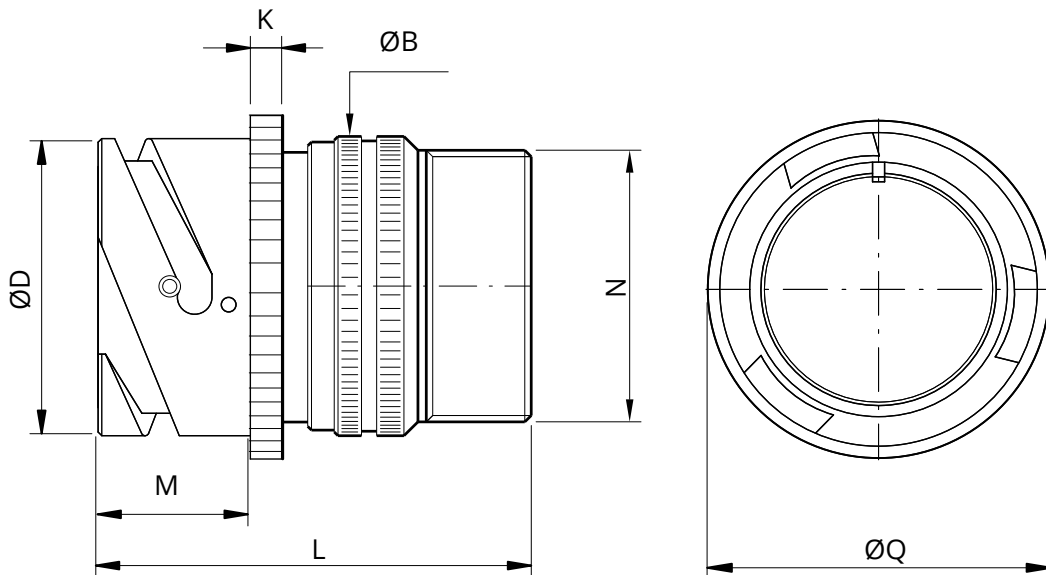

Shell size	ØD +0 -0.15	ØQ Max	ØB ±0.2	L	K ±0.2	M ±0.2	N Backshell Thread in inches
10SL	18.2	22	20	41	2.8	14.2	5/8"-24 UNEF
14S	24.6	29	24	42.5	3.2	14.5	3/4"-20 UNEF
16S	27.4	31	27	42.5	3.2	14.2	7/8"-20 UNEF
16	27.4	31	27	50	3.2	19	7/8"-20 UNEF
18	30.8	34	30	52	4	19	1"-20 UNEF
20	34.2	37	32	51	4	19	1" 3/16-18 UNEF
22	37.4	40	37	54	4	19.7	1" 3/16-18 UNEF
24	40.9	44	40	54	4	20.6	1" 7/16-18 UNEF
28	46.7	49.5	45	62	4	20.6	1" 7/16-18 UNEF
32	53.4	56	52	63	4	22.2	1" 3/4-18 UNS
36	59.6	62.5	58	63	4	22.2	2"-18 UNS
40	65.5	68.5	63.2	63	4	22.2	2" 1/4-16 UN

Dimensions in mm

Dimension "L" can be different from the value indicated according to backshells accessories, wires size and some special insert configurations.

CVBS - Bayonet Connector with protected mating ramps



Series Code: CVBS Shell Material: [blank] Shell Type: 01 Connector Class: DA T 20-27 S X CR CD5 Shell finish: F7 N

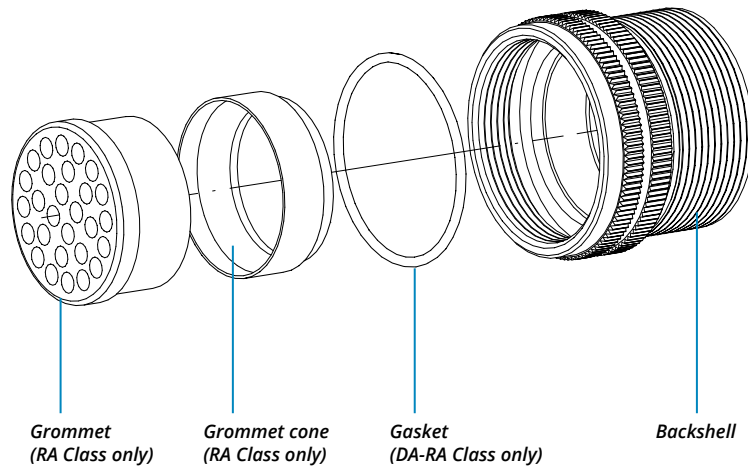

RF	Insulating material	-	Chloroprene rubber
		V	Fluoride rubber
		S	Silicone rubber
		RF	Fire resistant rubber
CVBS	Series Code	CVBS	Bayonet Connector with protected mating ramps
[blank]	Shell Material	-	Aluminum
01	Shell Type	01	In-line receptacle
DA	Connector Class	A	non watertight
		DA	with waterproof O-ring (IP67***)
		RA	with waterproof O-ring and grommet (IP67***)
T	Connector Modification**	T	With plastic caps
20-27	Insert Arrangement		Size - Type

S	Contact Gender	S	Socket contacts
		P	Pin contacts
X	Polarization Code**		Alternate Positions
CR	Contact Termination	-	Solder contacts
		CR	Crimp contacts
		LC	Less contacts
CD5	Contact Plating	-	Silver plating
		CD5	Gold plating
		F5	Electroless nickel (*)
F7	Shell finish	F7	Black epoxy varnish (*)
		F16	CCF - Black passivation (*) - conductive
		F26	hard anodization (*)
N	Modification Code**	N	Consult our sales office
		S	

*** Protection degree: IP 67 (only in the mating area with mated connectors) according to EN 60529 (*) RoHS compliance (**) If required

P/N Sample: RF CVBS 01DAT 20-27SX CR CD5 F7 N

CVBS - Bayonet Connector with protected mating ramps

In-Line Receptacle (01) with Backshell Class (LA - LDA - LRA)

Connector with long backshell provided with an external thread suitable for MS3057...A or C type Cable-Clamps (to be ordered separately).

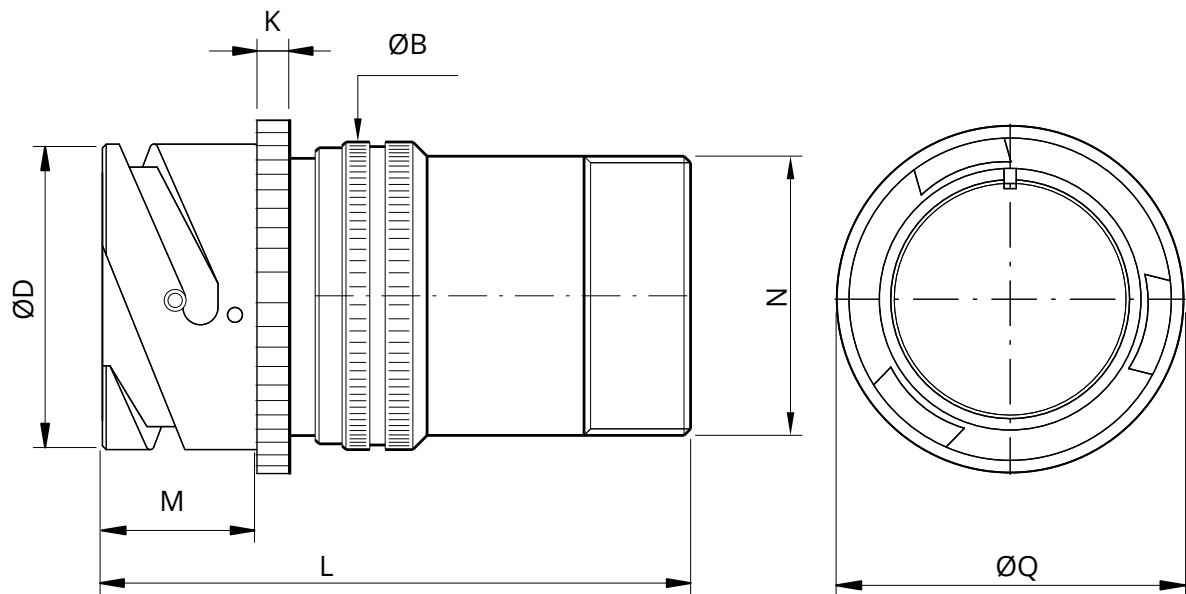

Shell size	ØD +0 -0.15	ØQ Max	ØB ±0.2	L	K ±0.2	M ±0.2	N Backshell Thread in inches
10SL	18.2	22	20	67	2.8	14.2	5/8"-24 UNEF
14S	24.6	29	24	67	3.2	14.5	3/4"-20 UNEF
16S	27.4	31	27	67	3.2	14.2	7/8"-20 UNEF
16	27.4	31	27	77	3.2	19	7/8"-20 UNEF
18	30.8	34	30	77.5	4	19	1"-20 UNEF
20	34.2	37	32	78	4	19	1" 3/16-18 UNEF
22	37.4	40	37	79	4	19.7	1" 3/16-18 UNEF
24	40.9	44	40	81	4	20.6	1" 7/16-18 UNEF
28	46.7	49.5	45	81	4	20.6	1" 7/16-18 UNEF
32	53.4	56	52	95.5	4	22.2	1" 3/4-18 UNS
36	59.6	62.5	58	95.5	4	22.2	2"-18 UNS
40	65.5	68.5	63.2	95.5	4	22.2	2" 1/4-16 UN

Dimensions in mm

Dimension "L" can be different from the value indicated according to backshells accessories, wires size and some special insert configurations.

CVBS - Bayonet Connector with protected mating ramps



Series Code Shell Material Type Shell Class Connector Class

Shell finish

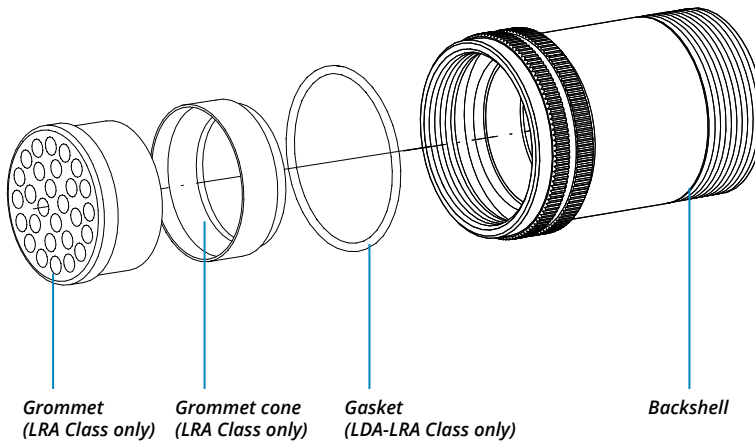

RF	Insulating material	-	Chloroprene rubber	S	Contact Gender	S	Socket contacts
		V	Fluoride rubber			P	Pin contacts
		S	Silicone rubber				
		RF	Fire resistant rubber				
CVBS	Series Code	CVBS	Bayonet Connector with protected mating ramps	X	Polarization Code**		Alternate Positions
[]	Shell Material	-	Aluminum	CR	Contact Termination	-	Solder contacts
		CR	Crimp contacts			LC	Less contacts
01	Shell Type	01	In-line receptacle	CD5	Contact Plating	-	Silver plating
		F5	Electroless nickel (*)			CD5	Gold plating
LDA	Connector Class	LA	non watertight	F7	Shell finish	F7	Black epoxy varnish (*)
		LDA	with waterproof O-ring (IP67***)			F16	CCF - Black passivation (*) - conductive
		LRA	with waterproof O-ring and grommet (IP67***)			F26	hard anodization (*)
T	Connector Modification**	T	With plastic caps	N	Modification Code**	N	Consult our sales office
		S				S	
20-27	Insert Arrangement		Size - Type				

*** Protection degree: IP 67 (only in the mating area with mated connectors) according to EN 60529 (*) RoHS compliance (***) If required

P/N Sample: RF CVBS 01LDAT 20-27SX CR CD5 F7 N

CVBS - Bayonet Connector with protected mating ramps

In-Line Receptacle (01) with Backshell Class (AF - F)

Connector provided with backshell, MS3057...A type Cable-Clamp and bushing MS3420...(for single wire)

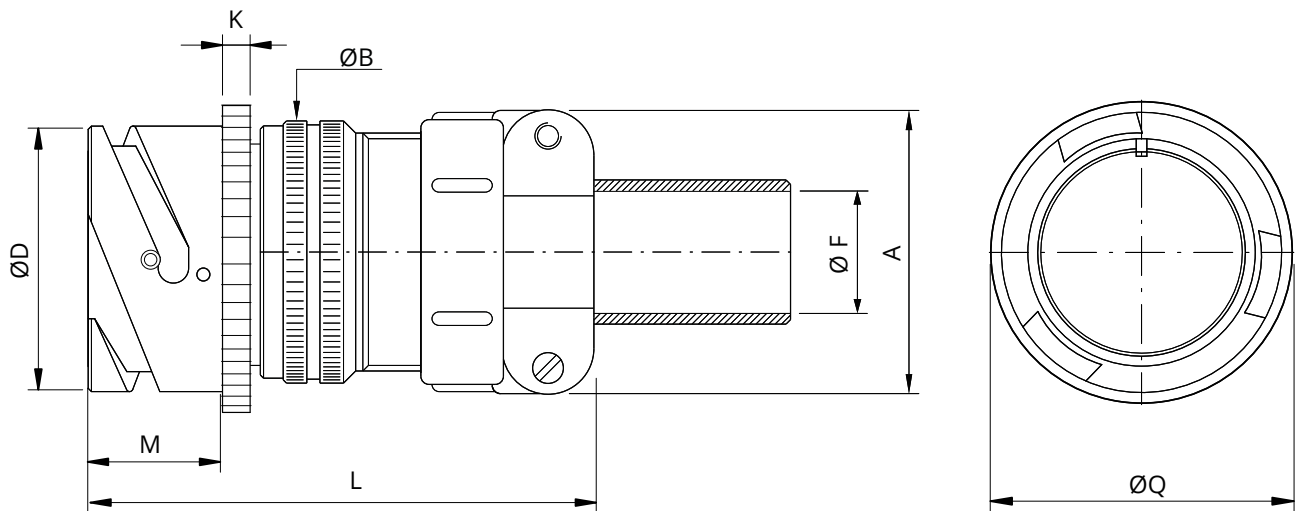

Shell size	ØD +0 -0.15	ØQ Max	ØB ±0.2	L	K ±0.2	M ±0.2	A max	ØF cable max dimension
10SL	18.2	22	20	51	2.8	14.2	22.5	5.6
14S	24.6	29	24	54.5	3.2	14.5	28	7.9
16S	27.4	31	27	56	3.2	14.2	30	11
16	27.4	31	27	63.5	3.2	19	30	11
18	30.8	34	30	66.5	4	19	31.7	14.2
20	34.2	37	32	66.5	4	19	37.5	15.8
22	37.4	40	37	69.5	4	19.7	37.5	15.8
24	40.9	44	40	69.5	4	20.6	43.5	19
28	46.7	49.5	45	77.5	4	20.6	43.5	19
32	53.4	56	52	78.5	4	22.2	51.7	23.8
36	59.6	62.5	58	78.5	4	22.2	58.5	31.7
40	65.5	68.5	63.2	92	4	22.2	68.5	34.9

Dimensions in mm

Dimension "L" can be different from the value indicated according to backshells accessories, wires size and some special insert configurations.

CVBS - Bayonet Connector with protected mating ramps



Series Code: **CVBS** Shell Material: **[Empty]** Shell Type: **01** Connector Class: **AF** Modification: **T** Insert Arrangement: **20-27** Contact Gender: **S** Polarization Code: **X** Contact Termination: **[Empty]** Contact Plating: **CR** Contact Plating: **CD5** Shell finish: **F7** Modification Code: **N**

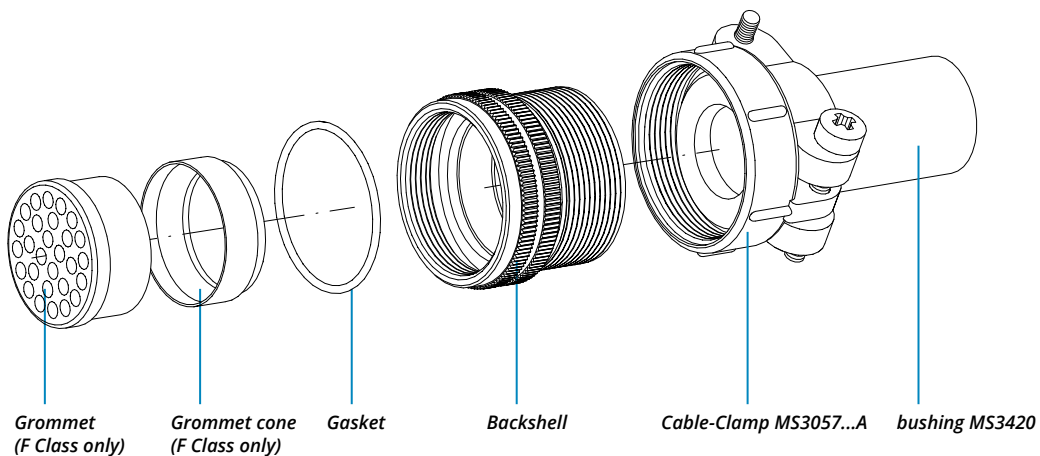

RF	Insulating material	-	Chloroprene rubber
		V	Fluoride rubber
		S	Silicone rubber
		RF	Fire resistant rubber
CVBS	Series Code	CVBS	Bayonet Connector with protected mating ramps
[Empty]	Shell Material	-	Aluminum
01	Shell Type	01	In-line receptacle
AF	Connector Class	F	with waterproof O-ring and grommet (IP54)
		AF	with waterproof O-ring (IP54)
T	Connector Modification**	T	With plastic caps
20-27	Insert Arrangement		Size - Type

S	Contact Gender	S	Socket contacts
		P	Pin contacts
X	Polarization Code**		Alternate Positions
CR	Contact Termination	-	Solder contacts
		CR	Crimp contacts
		LC	Less contacts
CD5	Contact Plating	-	Silver plating
		CD5	Gold plating
		F5	Electroless nickel (*)
F7	Shell finish	F7	Black epoxy varnish (*)
		F16	CCF - Black passivation (*) - conductive
		F26	hard anodization (*)
N	Modification Code**	N	Consult our sales office
		S	

P/N Sample: RF CVBS 01AFT 20-27SX CR CD5 F7 N

(*) RoHS compliance

(**) If required

CVBS - Bayonet Connector with protected mating ramps

In-Line Receptacle (01) with Backshell Class (LAF - LF)

Connector provided with long backshell, MS3057...A type Cable-Clamp and bushing MS3420... (for single wire)

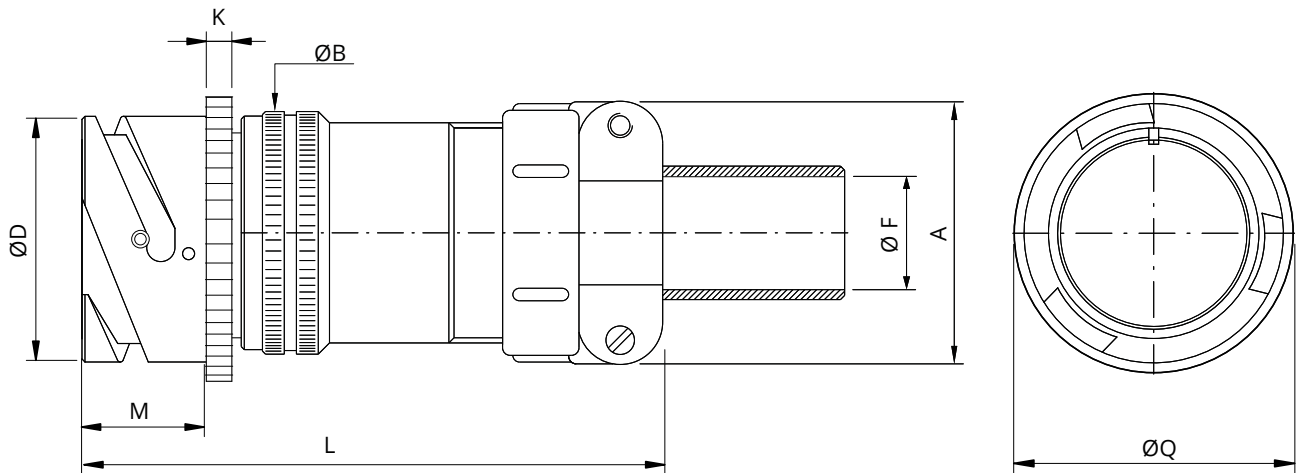

Shell size	ØD +0 -0.15	ØQ Max	ØB ±0.2	L	K ±0.2	M ±0.2	A max	ØF cable max dimension
10SL	18.2	22	20	77	2.8	14.2	22.5	5.6
14S	24.6	29	24	79	3.2	14.5	28	7.9
16S	27.4	31	27	80.5	3.2	14.2	30	11
16	27.4	31	27	90.5	3.2	19	30	11
18	30.8	34	30	93	4	19	31.7	14.2
20	34.2	37	32	93.5	4	19	37.5	15.8
22	37.4	40	37	94.5	4	19.7	37.5	15.8
24	40.9	44	40	96.5	4	20.6	43.5	19
28	46.7	49.5	45	96.5	4	20.6	43.5	19
32	53.4	56	52	111	4	22.2	51.7	23.8
36	59.6	62.5	58	111	4	22.2	58.5	31.7
40	65.5	68.5	63.2	124.5	4	22.2	68.5	34.9

Dimensions in mm

Dimension "L" can be different from the value indicated according to backshells accessories, wires size and some special insert configurations.

CVBS - Bayonet Connector with protected mating ramps



Series Code Shell Material Type Shell Type Connector Class

Shell finish

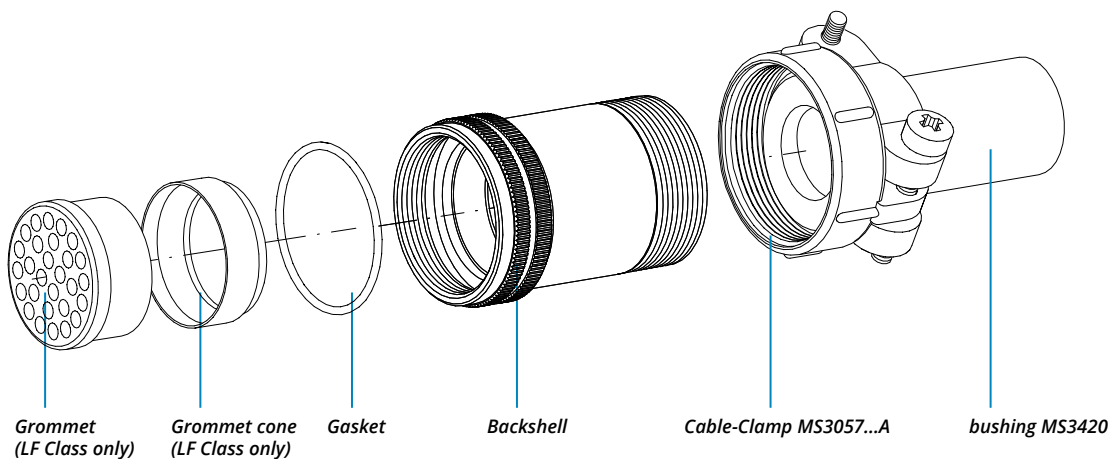

RF	Insulating material	-	Chloroprene rubber
		V	Fluoride rubber
		S	Silicone rubber
		RF	Fire resistant rubber
CVBS	Series Code	CVBS	Bayonet Connector with protected mating ramps
	Shell Material	-	Aluminum
01	Shell Type	01	In-line receptacle
LAF	Connector Class	LF	with waterproof O-ring and grommet (IP54)
		LAF	with waterproof O-ring (IP54)
T	Connector Modification**	T	With plastic caps
20-27	Insert Arrangement		Size - Type

S	Contact Gender	S	Socket contacts
		P	Pin contacts
X	Polarization Code**		Alternate Positions
CR	Contact Termination	-	Solder contacts
		CR	Crimp contacts
		LC	Less contacts
CD5	Contact Plating	-	Silver plating
		CD5	Gold plating
F7	Shell finish	F5	Electroless nickel (*)
		F7	Black epoxy varnish (*)
		F16	CCF - Black passivation (*) - conductive
		F26	hard anodization (*)
N	Modification Code**	N	Consult our sales office
		S	

P/N Sample: RF CVBS 01LAF T 20-27SX CR CD5 F7 N

(*) RoHS compliance

(**) If required

CVBS - Bayonet Connector with protected mating ramps

In-Line Receptacle (01) with Backshell Class (AC - ACF)

Connector provided with backshell, MS3057...C type Cable-Clamp (for jacketed cable)

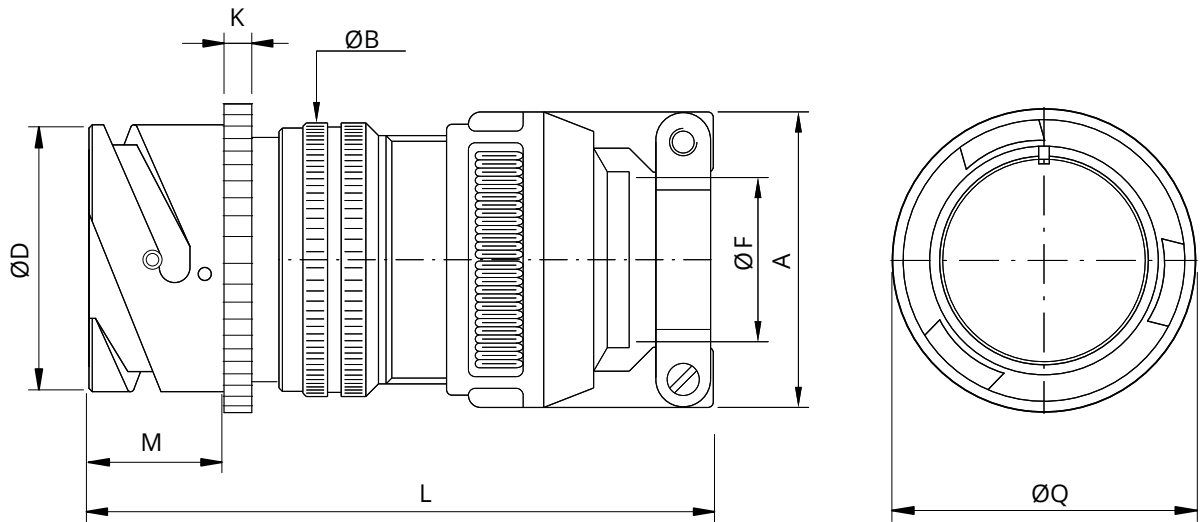

Shell size	ØD +0 -0.15	ØQ Max	ØB ±0.2	L	K ±0.2	M ±0.2	A max	ØF cable dimension	
								Min	Max
10SL	18.2	22	20	65	2.8	14.2	23	2.4	7.9
14S	24.6	29	24	66.5	3.2	14.5	26	5.8	11.2
16S	27.4	31	27	67.5	3.2	14.2	28.5	8	13.5
16	27.4	31	27	75	3.2	19	28.5	8	13.5
18	30.8	34	30	78.5	4	19	32	9.6	15.9
20	34.2	37	32	77.5	4	19	37.5	11.3	19
22	37.4	40	37	80.5	4	19.7	37.5	11.3	19
24	40.9	44	40	87.5	4	20.6	43.5	15.5	23.8
28	46.7	49.5	45	95.5	4	20.6	43.5	15.5	23.8
32	53.4	56	52	101	4	22.2	54	23.4	31.8
36	59.6	62.5	58	105.5	4	22.2	58	25.4	35
40	65.5	68.5	63.2	107	4	22.2	63.5	30	41.3

Dimensions in mm

Dimension "L" can be different from the value indicated according to backshells accessories, wires size and some special insert configurations.

CVBS - Bayonet Connector with protected mating ramps



Series Code: RF Shell Material: CVBS Shell Type: 01 Connector Class: AC T 20-27 S X CR CD5 Shell finish: F7 N

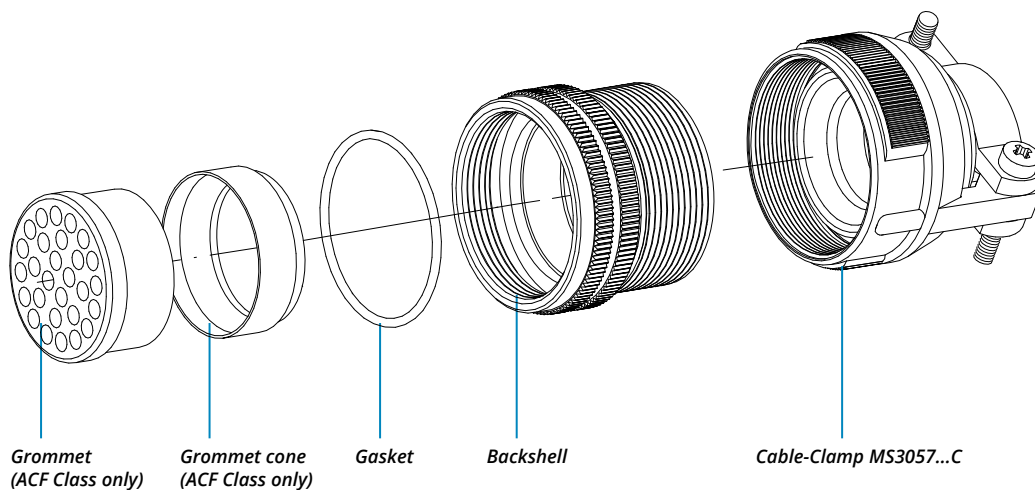

RF	Insulating material	-	Chloroprene rubber
		V	Fluoride rubber
		S	Silicone rubber
		RF	Fire resistant rubber
CVBS	Series Code	CVBS	Bayonet Connector with protected mating ramps
	Shell Material	-	Aluminum
01	Shell Type	01	In-line receptacle
AC	Connector Class	AC	with waterproof O-ring (IP67)
		ACF	with waterproof O-ring and grommet (IP67)
T	Connector Modification**	T	With plastic caps
20-27	Insert Arrangement		Size - Type

S	Contact Gender	S	Socket contacts
		P	Pin contacts
X	Polarization Code**		Alternate Positions
CR	Contact Termination	-	Solder contacts
		CR	Crimp contacts
		LC	Less contacts
CD5	Contact Plating	-	Silver plating
		CD5	Gold plating
		F5	Electroless nickel (*)
		F7	Black epoxy varnish (*)
F7	Shell finish	F16	CCF - Black passivation (*) - conductive
		F26	hard anodization (*)
		N	Consult our sales office
N	Modification Code**	N	Consult our sales office
		S	

P/N Sample: RF CVBS 01ACT 20-27SX CR CD5 F7 N

(*) RoHS compliance

(**) If required

CVBS - Bayonet Connector with protected mating ramps

In-Line Receptacle (01) with Backshell Class (ACB)

Connector provided with backshell, MS3057...C type Cable-Clamp and bushing MS 3420A (for jacketed cable)

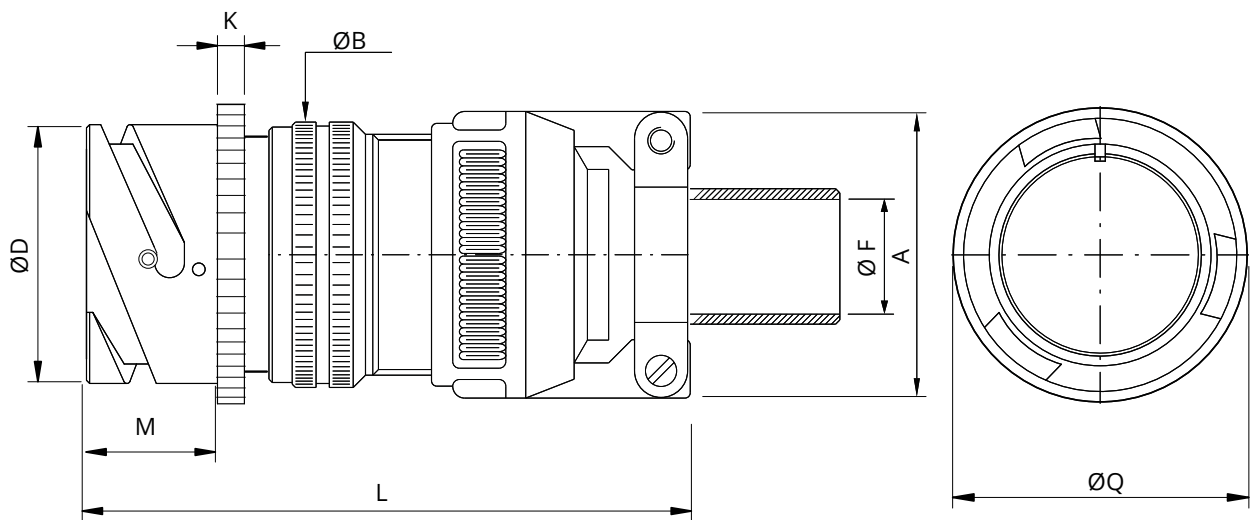

Shell size	ØD +0 -0.15	ØQ Max	ØB ±0.2	L	K ±0.2	M ±0.2	A max	ØF max cable size
10SL	18.2	22	20	65	2.8	14.2	23	5.6
14S	24.6	29	24	66.5	3.2	14.5	26	7.9
16S	27.4	31	27	67.5	3.2	14.2	28.5	11.1
16	27.4	31	27	75	3.2	19	28.5	11.1
18	30.8	34	30	78.5	4	19	32	11.1
20	34.2	37	32	77.5	4	19	37.5	13.7
22	37.4	40	37	80.5	4	19.7	37.5	13.7
24	40.9	44	40	87.5	4	20.6	43.5	19
28	46.7	49.5	45	95.5	4	20.6	43.5	19
32	53.4	56	52	101	4	22.2	54	23.8
36	59.6	62.5	58	105.5	4	22.2	58	28.5
40	65.5	68.5	63.2	107	4	22.2	63.5	31.8

Dimensions in mm

Dimension "L" can be different from the value indicated according to backshells accessories, wires size and some special insert configurations.

CVBS - Bayonet Connector with protected mating ramps



Series Code: RF Shell Material: CVBS Shell Type: 01 Connector Class: ACB T 20-27 S X CR CD5 Shell finish: F7 N

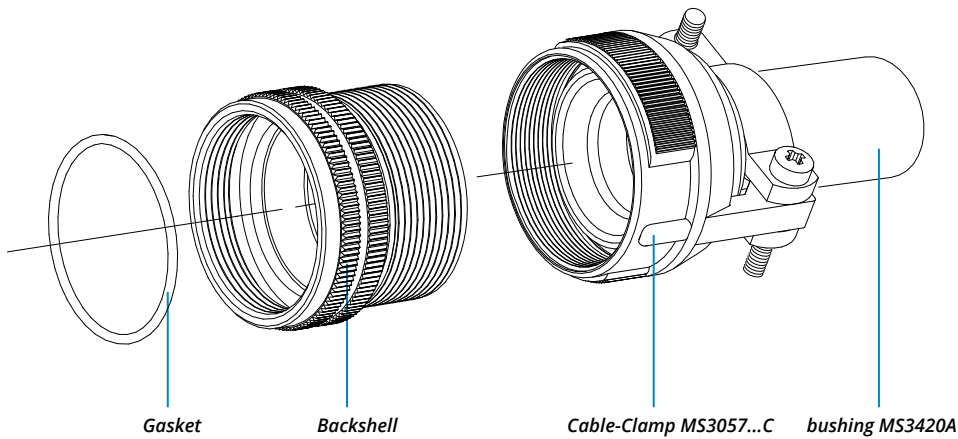

RF	Insulating material	-	Chloroprene rubber
		V	Fluoride rubber
		S	Silicone rubber
		RF	Fire resistant rubber
CVBS	Series Code	CVBS	Bayonet Connector with protected mating ramps
	Shell Material	-	Aluminum
01	Shell Type	01	In-line receptacle
ACB	Connector Class	ACB	with waterproof O-ring
T	Connector Modification**	T	With plastic caps
20-27	Insert Arrangement		Size - Type

S	Contact Gender	S	Socket contacts
		P	Pin contacts
X	Polarization Code**		Alternate Positions
CR	Contact Termination	-	Solder contacts
		CR	Crimp contacts
		LC	Less contacts
CD5	Contact Plating	-	Silver plating
		CD5	Gold plating
		F5	Electroless nickel (*)
F7	Shell finish	F7	Black epoxy varnish (*)
		F16	CCF - Black passivation (*) - conductive
		F26	hard anodization (*)
N	Modification Code**	N	Consult our sales office
		S	

P/N Sample: RF CVBS 01ACBT 20-27SX CR CD5 F7 N

(*) RoHS compliance

(**) If required

CVBS - Bayonet Connector with protected mating ramps

In-Line Receptacle (01) with Backshell Class (LAC - LACF)

Connector provided with long backshell, MS3057...C type Cable-Clamp (for jacketed cable)

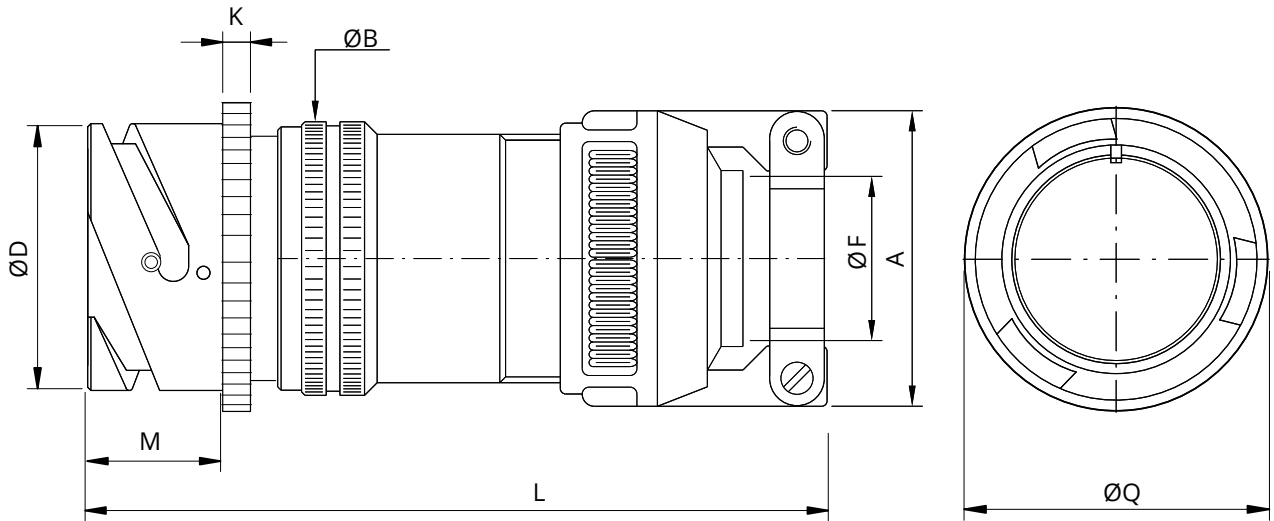

Shell size	ØD +0 -0.15	ØQ Max	ØB ±0.2	L	K ±0.2	M ±0.2	A max	ØF cable dimension	
								Min	Max
10SL	18.2	22	20	91	2.8	14.2	23	2.4	7.9
14S	24.6	29	24	91	3.2	14.5	26	5.8	11.2
16S	27.4	31	27	92	3.2	14.2	28.5	8	13.5
16	27.4	31	27	102	3.2	19	28.5	8	13.5
18	30.8	34	30	105	4	19	32	9.6	15.9
20	34.2	37	32	105	4	19	37.5	11.3	19
22	37.4	40	37	106	4	19.7	37.5	11.3	19
24	40.9	44	40	114.5	4	20.6	43.5	15.5	23.8
28	46.7	49.5	45	114.5	4	20.6	43.5	15.5	23.8
32	53.4	56	52	133.5	4	22.2	54	23.4	31.8
36	59.6	62.5	58	138	4	22.2	58	25.4	35
40	65.5	68.5	63.2	139.5	4	22.2	63.5	30	41.3

Dimensions in mm

Dimension "L" can be different from the value indicated according to backshells accessories, wires size and some special insert configurations.

CVBS - Bayonet Connector with protected mating ramps



Series Code Shell Material Type Shell Type Connector Class

Shell finish

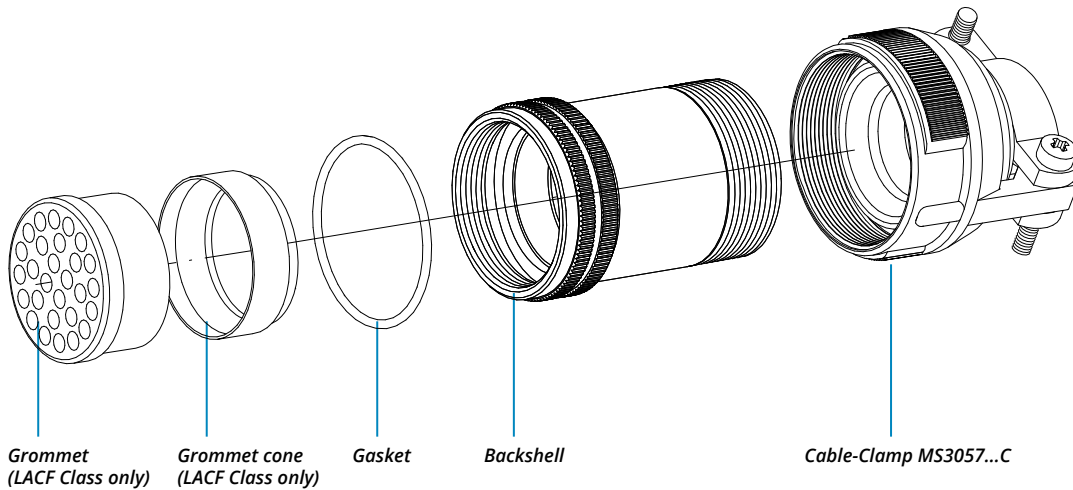

RF	Insulating material	-	Chloroprene rubber
		V	Fluoride rubber
		S	Silicone rubber
		RF	Fire resistant rubber
CVBS	Series Code	CVBS	Bayonet Connector with protected mating ramps
	Shell Material	-	Aluminum
01	Shell Type	01	In-line receptacle
LAC	Connector Class	LAC	with waterproof O-ring (IP67)
		LACF	with waterproof O-ring and grommet (IP67)
T	Connector Modification**	T	With plastic caps
20-27	Insert Arrangement		Size - Type

S	Contact Gender	S	Socket contacts
		P	Pin contacts
X	Polarization Code**		Alternate Positions
CR	Contact Termination	-	Solder contacts
		CR	Crimp contacts
		LC	Less contacts
CD5	Contact Plating	-	Silver plating
		CD5	Gold plating
		F5	Electroless nickel (*)
F7	Shell finish	F7	Black epoxy varnish (*)
		F16	CCF - Black passivation (*) - conductive
		F26	hard anodization (*)
N	Modification Code**	N	Consult our sales office
		S	

P/N Sample: RF CVBS 01LACT 20-27SX CR CD5 F7 N

(*) RoHS compliance

(**) If required

CVBS - Bayonet Connector with protected mating ramps

In-Line Receptacle (01) with Backshell Class (AB)

Connector provided with backshell, MS3057...B type Cable-Clamp (for jacketed cable)

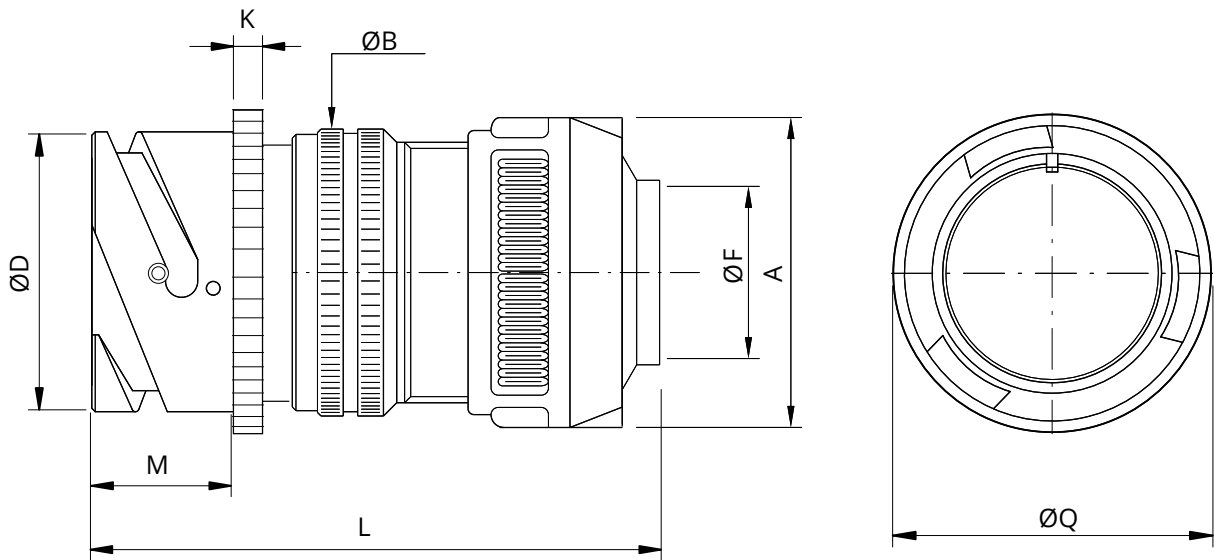

Shell size	ØD +0 -0.15	ØQ Max	ØB ±0.2	L	K ±0.2	M ±0.2	A max	ØF cable dimension	
								Min	Max
10SL	18.2	22	20	48.4	2.8	14.2	23	2.4	7.9
14S	24.6	29	24	56.1	3.2	14.5	26	5.8	11.2
16S	27.4	31	27	57.3	3.2	14.2	28.5	8	13.5
16	27.4	31	27	63.3	3.2	19	28.5	8	13.5
18	30.8	34	30	68	4	19	32	9.6	15.9
20	34.2	37	32	69.2	4	19	37.5	11.3	19
22	37.4	40	37	71.2	4	19.7	37.5	11.3	19
24	40.9	44	40	76.3	4	20.6	43.5	15.5	23.8
28	46.7	49.5	45	83.3	4	20.6	43.5	15.5	23.8
32	53.4	56	52	85.1	4	22.2	54	23.4	31.8
36	59.6	62.5	58	88.2	4	22.2	58	25.4	35
40	65.5	68.5	63.2	91.5	4	22.2	63.5	30	41.3

Dimensions in mm

Dimension "L" can be different from the value indicated according to backshells accessories, wires size and some special insert configurations.

CVBS - Bayonet Connector with protected mating ramps



Series Code Shell Material Type Connector Class

Shell finish

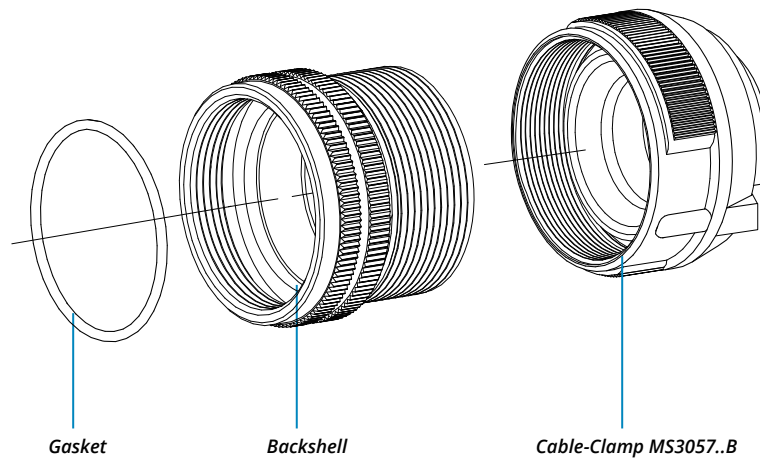

RF	Insulating material	-	Chloroprene rubber
		V	Fluoride rubber
		S	Silicone rubber
		RF	Fire resistant rubber
CVBS	Series Code	CVBS	Bayonet Connector with protected mating ramps
	Shell Material	-	Aluminum
01	Shell Type	01	In-line receptacle
AB	Connector Class	AB	with waterproof O-ring
T	Connector Modification**	T	With plastic caps
20-27	Insert Arrangement		Size - Type

S	Contact Gender	S	Socket contacts
		P	Pin contacts
X	Polarization Code**		Alternate Positions
CR	Contact Termination	-	Solder contacts
		CR	Crimp contacts
		LC	Less contacts
CD5	Contact Plating	-	Silver plating
		CD5	Gold plating
		F5	Electroless nickel (*)
		F7	Black epoxy varnish (*)
F7	Shell finish	F16	CCF - Black passivation (*) - conductive
		F26	hard anodization (*)
		N	Consult our sales office
N	Modification Code**	N	Consult our sales office
		S	Consult our sales office

P/N Sample: RF CVBS 01ABT 20-27SX CR CD5 F7 N

(*) RoHS compliance

(**) If required

CVBS - Bayonet Connector with protected mating ramps

In-Line Receptacle (01) with Backshell Class (ASF)

Connector provided with backshell, MS3057...A type Cable-Clamp (for single wire)

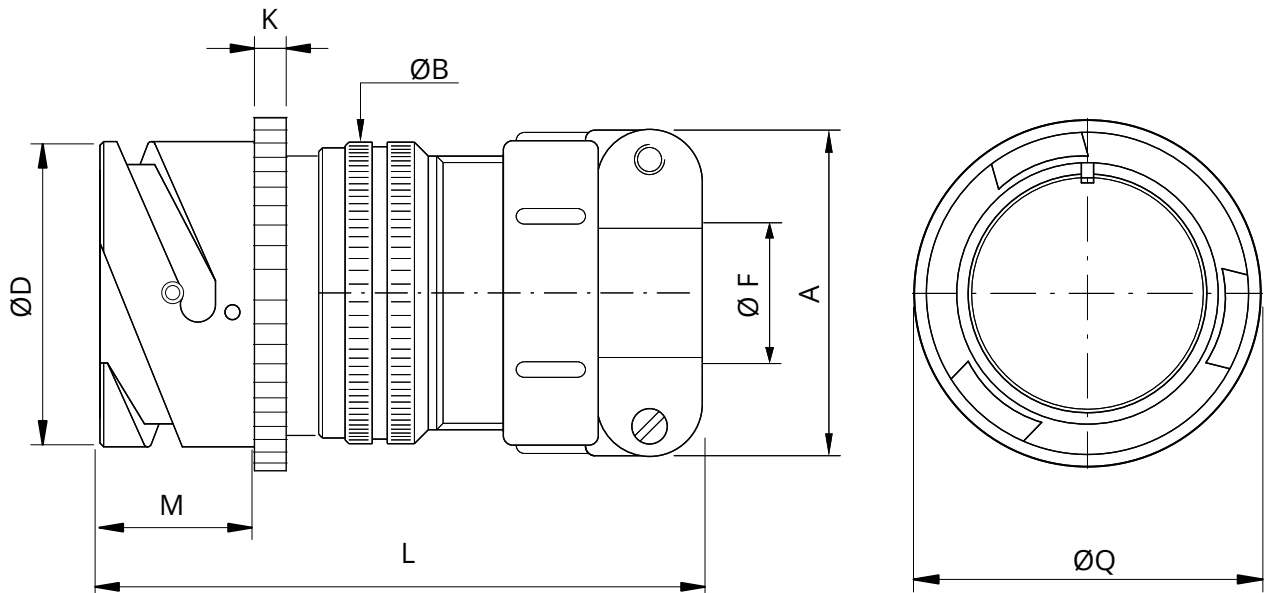

Shell size	ØD +0 -0.15	ØQ Max	ØB ±0.2	L	K ±0.2	M ±0.2	A max	ØF cable max dimension
10SL	18.2	22	20	51	2.8	14.2	22.5	8
14S	24.6	29	24	54.5	3.2	14.5	28	11
16S	27.4	31	27	56	3.2	14.2	30	14.2
16	27.4	31	27	63.5	3.2	19	30	14.2
18	30.8	34	30	66.5	4	19	31.7	15.8
20	34.2	37	32	66.5	4	19	37.5	19
22	37.4	40	37	69.5	4	19.7	37.5	19
24	40.9	44	40	69.5	4	20.6	43.5	23.8
28	46.7	49.5	45	77.5	4	20.6	43.5	23.8
32	53.4	56	52	78.5	4	22.2	51.7	31.7
36	59.6	62.5	58	78.5	4	22.2	58.5	35
40	65.5	68.5	63.2	92	4	22.2	68.5	41.2

Dimensions in mm

Dimension "L" can be different from the value indicated according to backshells accessories, wires size and some special insert configurations.

CVBS - Bayonet Connector with protected mating ramps



Series Code: RF
 Shell Material: CVBS
 Shell Type: 01
 Connector Class: ASF

Shell finish: F7

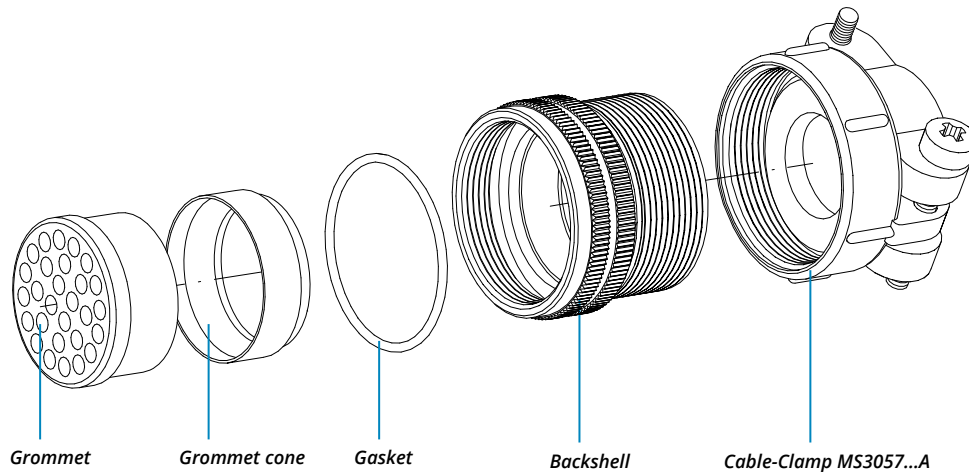

RF	Insulating material	-	Chloroprene rubber
		V	Fluoride rubber
		S	Silicone rubber
		RF	Fire resistant rubber
CVBS	Series Code	CVBS	Bayonet Connector with protected mating ramps
[]	Shell Material	-	Aluminum
01	Shell Type	01	In-line receptacle
ASF	Connector Class	ASF	with waterproof O-ring and grommet
T	Connector Modification**	T	With plastic caps
20-27	Insert Arrangement		Size - Type

S	Contact Gender	S	Socket contacts
		P	Pin contacts
X	Polarization Code**		Alternate Positions
CR	Contact Termination	-	Solder contacts
		CR	Crimp contacts
		LC	Less contacts
CD5	Contact Plating	-	Silver plating
		CD5	Gold plating
		F5	Electroless nickel (*)
		F7	Black epoxy varnish (*)
F7	Shell finish	F16	CCF - Black passivation (*) - conductive
		F26	hard anodization (*)
		N	Consult our sales office
N	Modification Code**	N	Consult our sales office
		S	

P/N Sample: RF CVBS 01ASF T 20-27SX CR CD5 F7 N

(*) RoHS compliance

(**) If required

CVBS - Bayonet Connector with protected mating ramps

In-Line Receptacle (01) with Backshell Class (DA...M - RA...M - DA...PG - RA...PG)

Connector with backshell provided with an internal Metric or PG thread suitable for Cable Glands or conduit adapters.

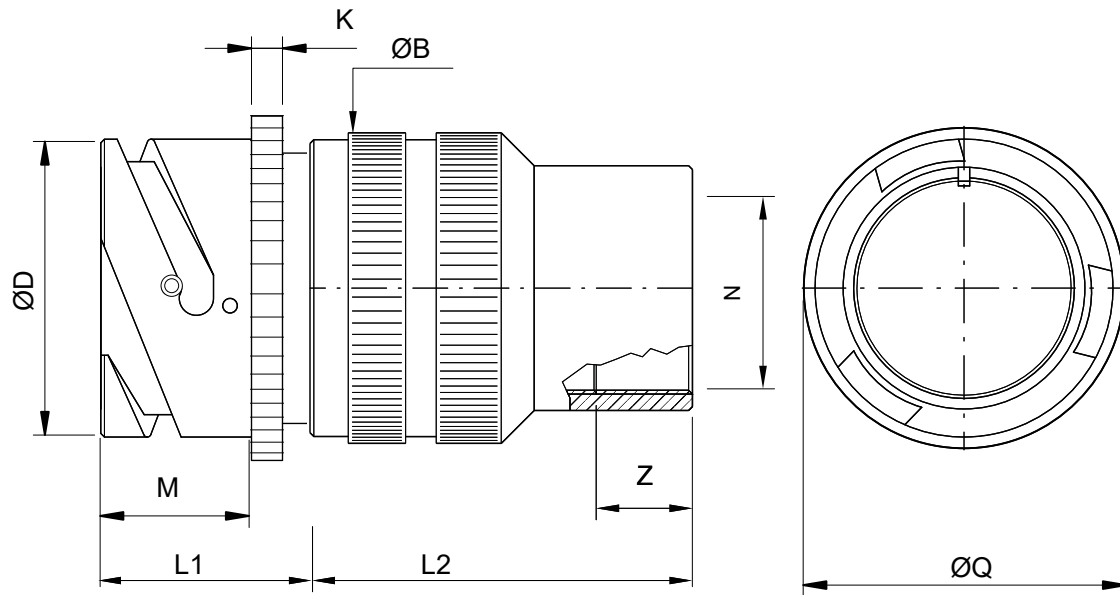

Shell size	ØD +0 -0.15	ØQ Max	ØB ±0.2	M ±0.2	K ±0.2	Z min	L1	N Backshell Metric thread	L2 M	N Backshell PG Thread	L2 PG
10SL	18.2	22	20	14.2	2.8	8	18,2	M12 - M16	32	(PG9) - PG13.5	26
14S	24.6	29	24	14.5	3.2	9	19,3	M12 - M16 - (M20) - (M25)	30	(PG9) - PG11 - PG13.5 - (PG16)	30
16S	27.4	31	27	14.2	3.2	9	18,5	(M16) - M20	40	PG13.5 - (PG16)	38
16	27.4	31	27	19	3.2	9	24,4	M20	45	-	40
18	30.8	34	30	19	4	9	24	M20 - M25	50	(PG11) - (PG13.5) - PG16 - PG21	50
20	34.2	37	32	19	4	9	24,2	M16 - M20 - M25 - (M32)	50	PG11-PG13.5-PG16-PG21-PG29	50
22	37.4	40	37	19.7	4	10	24,5	M16 - M20 - M25 - M32	50	PG13.5 - (PG16) - (PG29)	50
24	40.9	44	40	20.6	4	10	25,7	M20 - M25 - M32 - M40	50	PG16 - PG21 - PG29	50
28	46.7	49.5	45	20.6	4	10	26,1	(M25) - M32 - M40	63	PG21 - PG29 - PG36	60
32	53.4	56	52	22.2	4	10	27,9	(M25) - (M32) - M40	55	PG21 - (PG29) - PG36	60
36	59.6	62.5	58	22.2	4	13	28,7	M40 - M50	56	PG29 - (PG36) - (PG42)	65
40	65.5	68.5	63.2	22.2	4	13	28	M40 - (M50) - M63	65	PG29 - (PG36) - (PG42) - (PG48)	65

Dimensions in mm

Dimensions "L1 and L2" can be different from the value indicated according to backshells accessories, wires size and some special insert configurations.

(...) The threads in parentheses are versions on request with non standard backshell length (the dimensions L2 and Z are different from this page indication).

Please consult our sales office for the specific dimensions.

CVBS - Bayonet Connector with protected mating ramps



Series Code Shell Material Type Shell Class Connector Class

Backshell internal thread

Shell finish

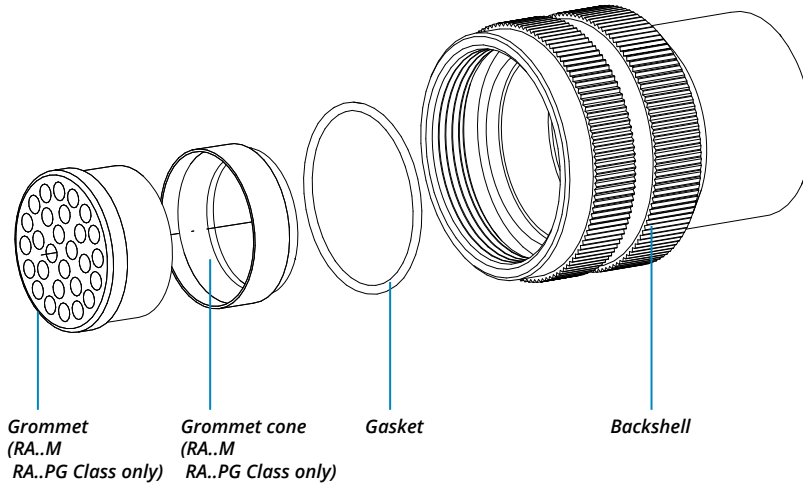

RF	Insulating material	-	Chloroprene rubber	X	Polarization Code**	Alternate Positions			
		V	Fluoride rubber			M12	Backshell internal thread	M	Provided with an internal Metric thread
		S	Silicone rubber					PG	Provided with an internal PG thread
		RF	Fire resistant rubber					-	Solder contacts
CR	Contact Termination	CR	Crimp contacts						
CVBS	Series Code	CVBS	Bayonet Connector with protected mating ramps	CD5	Contact Plating	-	Silver plating		
						CD5	Gold plating		
01	Shell Type	01	In-line receptacle	F7	Shell finish	F5	Electroless nickel (*)		
						F7	Black epoxy varnish (*)		
DA	Connector Class	DA	with waterproof O-ring (IP67***)	N	Modification Code**	F16	CCF - Black passivation (*) - conductive		
		RA	with waterproof O-ring and grommet (IP67***)			F26	hard anodization (*)		
T	Connector Modification**	T	With plastic caps	S		N	Consult our sales office		
20-27	Insert Arrangement		Size - Type						
S	Contact Gender	S	Socket contacts			S			
		P	Pin contacts						

*** Protection degree: IP 67 (only in the mating area with mated connectors) according to EN 60529 (*) RoHS compliance (***) If required

P/N Sample: RF CVBS 01DAT 20-27SX M12 CR CD5 F7 N

CVBS - Bayonet Connector with protected mating ramps

In-Line Receptacle (01) with Backshell Class (DA...MH - RA...MH - DA...PH - RA...PH)

Connector with backshell provided with a Metric or PG thread metal Cable Glands.

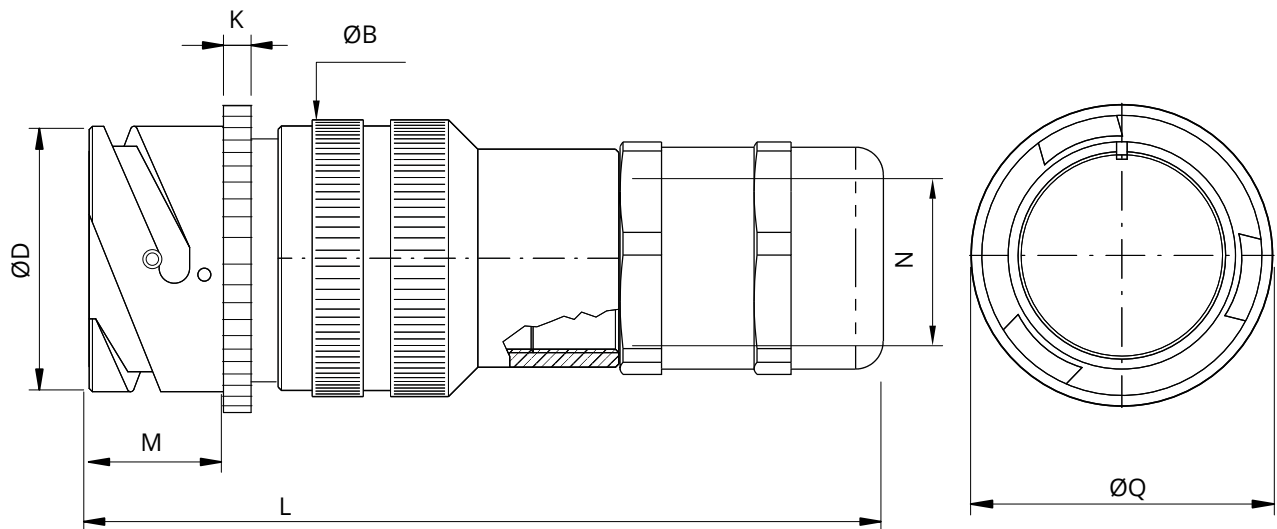

Shell size	ØD +0 -0.15	ØQ Max	ØB ±0.2	L max	K ±0.2	M ±0.2	Backshell Metric Thread	ØN Clamping range
10SL	18.2	22	20	87	2.8	14.2	M12	3.5-7
14S	24.6	29	24	93	3.2	14.5	M16	4.5-10
16S	27.4	31	27	96.5	3.2	14.2	M20	7-13
16	27.4	31	27	103.5	3.2	19	M20	7-13
18	30.8	34	30	103.5	4	19	M20	7-13
20	34.2	37	32	104.5	4	19	M25	9-17
22	37.4	40	37	110.5	4	19.7	M32	11-21
24	40.9	44	40	112.5	4	20.6	M32	11-21
28	46.7	49.5	45	122.5	4	20.6	M32	11-21
32	53.4	56	52	127	4	22.2	M40	19-28
36	59.6	62.5	58	132	4	22.2	M40	19-28
40	65.5	68.5	63.2	138	4	22.2	M40	19-28

Dimensions in mm

Dimension "L" can be different from the value indicated according to backshells accessories, wires size and some special insert configurations.

CVBS - Bayonet Connector with protected mating ramps



Series Code **Shell Material** **Shell Type** **Connector Class**

Backshell internal thread

Shell finish

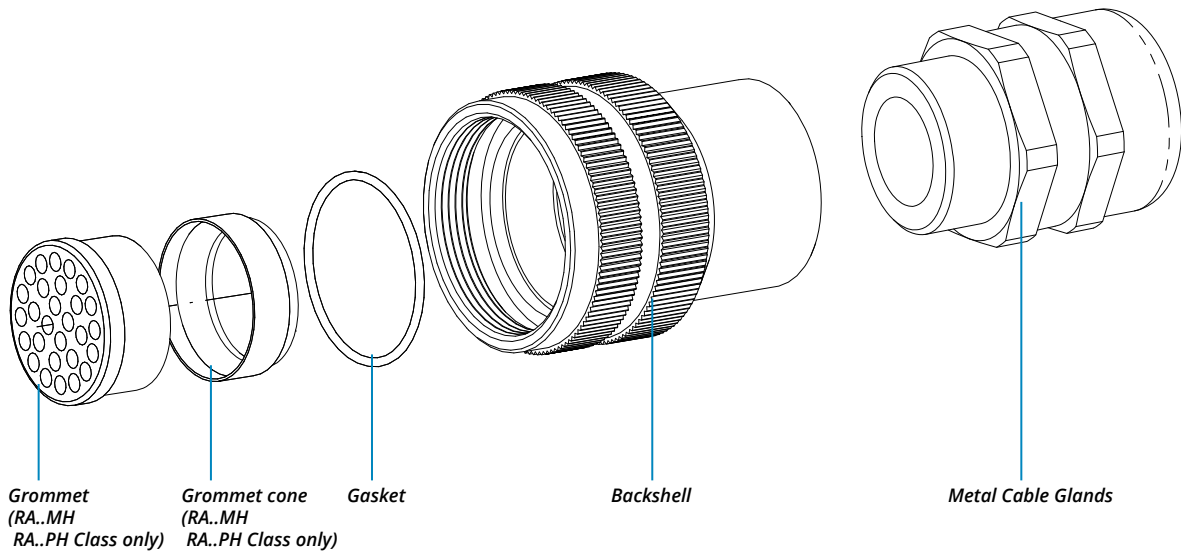

RF	Insulating material	-	Chloroprene rubber
		V	Fluoride rubber
		S	Silicone rubber
		RF	Fire resistant rubber
CVBS	Series Code	CVBS	Bayonet Connector with protected mating ramps
	Shell Material	-	Aluminum
01	Shell Type	01	In-line receptacle
DA	Connector Class	DA	with waterproof O-ring (IP67)
		RA	with waterproof O-ring and grommet (IP67)
T	Connector Modification**	T	With plastic caps
20-27	Insert Arrangement		Size - Type
S	Contact Gender	S	Socket contacts
		P	Pin contacts

X	Polarization Code**		Alternate Positions
MH12	Backshell internal thread	MH	Provided with a Metric thread Cable Glands
		PH	Provided with a PG thread Cable Glands***
CR	Contact Termination	-	Solder contacts
		CR	Crimp contacts
		LC	Less contacts
CD5	Contact Plating	-	Silver plating
		CD5	Gold plating
		F5	Electroless nickel (*)
F7	Shell finish	F7	Black epoxy varnish (*)
		F16	CCF - Black passivation (*) - conductive
		F26	hard anodization (*)
N	Modification Code**	N	Consult our sales office
		S	

P/N Sample: RF CVBS 01DAT 20-27SX MH12 CR CD5 F7 N (*) RoHS compliance (**) If required *** Consult our sales office

CVBS - Bayonet Connector with protected mating ramps

In-Line Receptacle (01) with Backshell Class (AR - R)

This class is suitable to connect single wires when strain relief is not necessary and small longitudinal overall dimensions are needed. As watertightness is guaranteed by the grommet only, it is necessary to make sure the wire diameter matches the grommet sealing range.

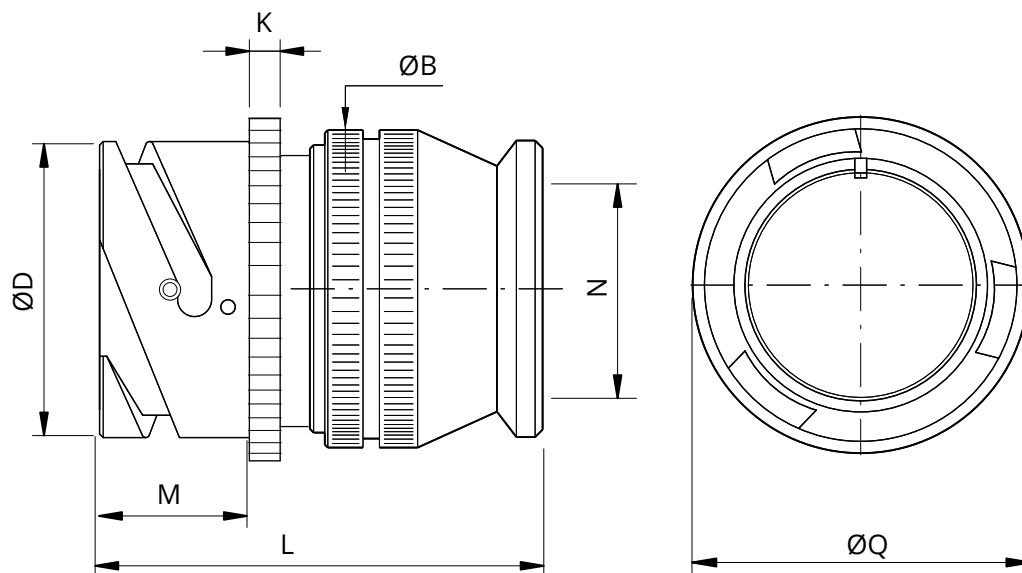

Shell size	ØD +0 -0.15	ØQ Max	ØB ±0.2	L	K ±0.2	M ±0.2	N max cable dimension
10SL	18.2	22	20	41	2.8	14.2	10
14S	24.6	29	24	42	3.2	14.5	13.5
16S	27.4	31	27	42	3.2	14.2	16.1
16	27.4	31	27	49	3.2	19	16.5
18	30.8	34	30	50	4	19	19
20	34.2	37	32	50	4	19	22.2
22	37.4	40	37	53	4	19.7	24.5
24	40.9	44	40	53	4	20.6	28
28	46.7	49.5	45	61	4	20.6	32.6
32	53.4	56	52	62	4	22.2	38
36	59.6	62.5	58	62	4	22.2	45
40	65.5	68.5	63.2	62	4	22.2	51.3

Dimensions in mm

Dimension "L" can be different from the value indicated according to backshells accessories, wires size and some special insert configurations.

CVBS - Bayonet Connector with protected mating ramps



Series Code Shell Material Type Shell Type Connector Class

Shell finish

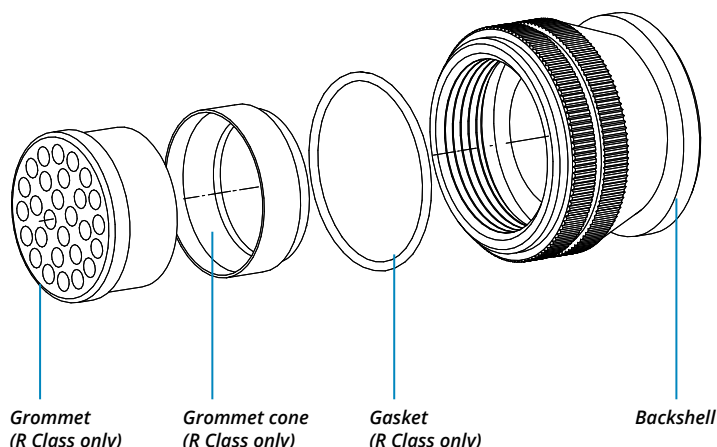

The accessories for this class are not always available in stock for all sizes; we suggest you consult our Sales Office for availability

RF	Insulating material	-	Chloroprene rubber	S	Contact Gender	S	Socket contacts	
		V	Fluoride rubber			P	Pin contacts	
		S	Silicone rubber		X	Polarization Code**	Alternate Positions	
		RF	Fire resistant rubber					
CVBS	Series Code	CVBS	Bayonet Connector with protected mating ramps	CR	Contact Termination	-	Solder contacts	
[]	Shell Material	-	Aluminum	CR		CR	Crimp contacts	
01	Shell Type	01	In-line receptacle	LC	LC	Less contacts		
R	Connector Class	AR	non watertight	CD5	Contact Plating	-	Silver plating	
R		R	with waterproof O-ring and grommet	F5		F5	Electroless nickel (*)	
T	Connector Modification**	T	With plastic caps	F7	F7	Black epoxy varnish (*)		
20-27	Insert Arrangement		Size - Type	F16	F16	CCF - Black passivation (*) - conductive		
				F26	F26	hard anodization (*)		
				N	Modification Code**	N	Consult our sales office	
				S		S		

P/N Sample: RF CVBS 01RT 20-27SX CR CD5 F7 N

(*) RoHS compliance

(**) If required

CVBS - Bayonet Connector with protected mating ramps

In-Line Receptacle (01) with Backshell Class (AG - G)

These classes of connectors are all suitable for heat shrink tubing applications.

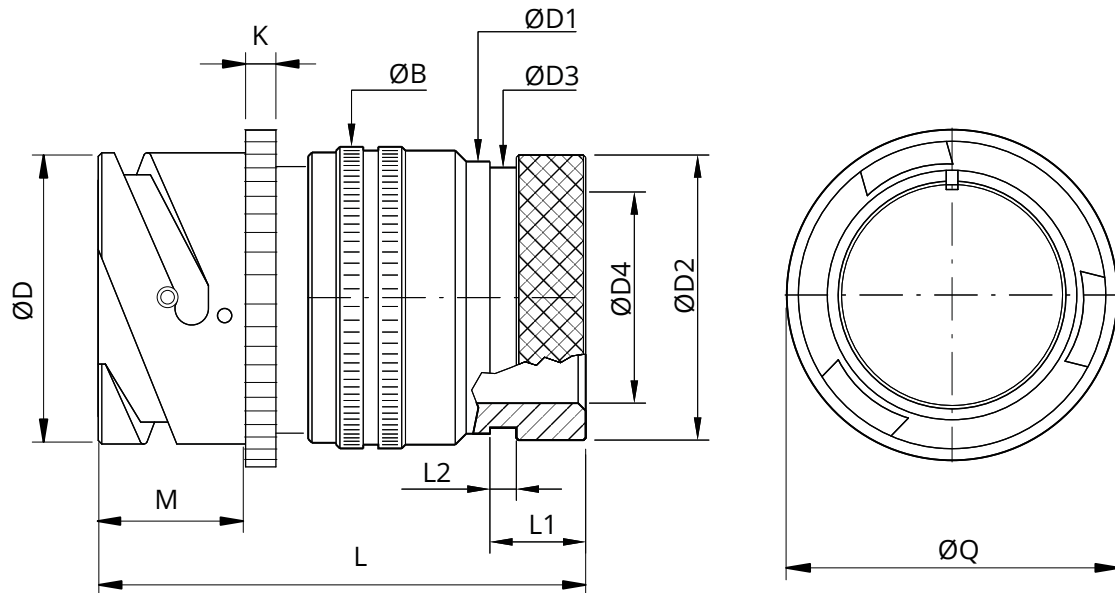

Shell size	ØD +0 -0.15	ØQ Max	ØB ±0.2	ØD1 ±0.2	ØD2 ±0.2	ØD3 ±0.2	ØD4 ±0.2	L	L1 ±0.2	L2 ±0.2	K ±0.2	M ±0.2
10SL	18.2	22	20	17	15.5	13.3	7.9	48	11.7	3.5	2.8	14.2
14S	24.6	29	24	20.1	19.1	17	13.5	48	11.7	3.5	3.2	14.5
16S	27.4	31	27	23.5	23.9	21.9	13.7	48	11.7	3.5	3.2	14.2
16	27.4	31	27	23.5	23.9	21.9	16.1	60	11.5	3.5	3.2	19
18	30.8	34	30	26.5	23.9	21.9	19	65	11.5	3.5	4	19
20	34.2	37	32	30.2	29.6	26.2	22.2	65	12.4	3.5	4	19
22	37.4	40	37	33.6	29.6	26.2	22	65	12.7	3.5	4	19.7
24	40.9	44	40	36.1	37.8	34.5	28	65	12.7	3.5	4	20.6
28	46.7	49.5	45	41.4	37.8	34.5	29	65	12.7	3.5	4	20.6
32	53.4	56	52	50	47.8	43.4	35.2	70	15.2	3.5	4	22.2
36	59.6	62.5	58	56	47.7	43.4	40	75	15.2	3.5	4	22.2
40	65.5	68.5	63.2	62.4	57.6	52.4	48	77	15.2	3.5	4	22.2

Dimensions in mm

Dimension "L" can be different from the value indicated according to backshells accessories, wires size and some special insert configurations.

CVBS - Bayonet Connector with protected mating ramps

RF	CVBS		01	AG	T	20-27	S	X		CR	CD5	F7		N
	Series Code	Shell Material	Shell Type	Connector Class								Shell finish		

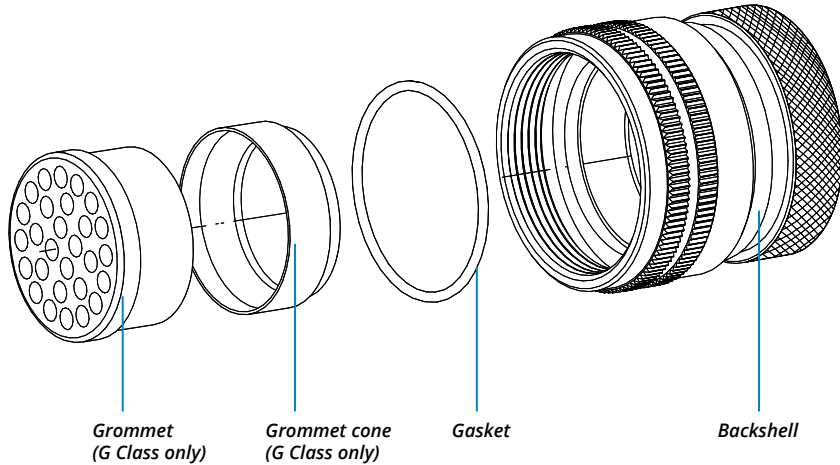

The accessories for this class are not always available in stock for all sizes; we suggest you consult our Sales Office for availability

RF	Insulating material	-	Chloroprene rubber	S	Contact Gender	S	Socket contacts	
		V	Fluoride rubber			P	Pin contacts	
		S	Silicone rubber		X	Polarization Code**	Alternate Positions	
		RF	Fire resistant rubber					
CVBS	Series Code	CVBS	Bayonet Connector with protected mating ramps	CR	Contact Termination	-	Solder contacts	
	Shell Material	-	Aluminum			CR	Crimp contacts	
						LC	Less contacts	
01	Shell Type	01	In-line receptacle	CD5	Contact Plating	-	Silver plating	
						CD5	Gold plating	
AG	Connector Class	AG	with waterproof O-ring (IP67***)	F7	Shell finish	F5	Electroless nickel (*)	
		G	with waterproof O-ring and grommet (IP67***)			F7	Black epoxy varnish (*)	
						F16	CCF - Black passivation (*) - conductive	
T	Connector Modification**	T	With plastic caps			F26	hard anodization (*)	
20-27	Insert Arrangement		Size - Type	N	Modification Code**	N	Consult our sales office	
						S		

*** Protection degree: IP 67 (only in the mating area with mated connectors) according to EN 60529 (*) RoHS compliance (***) If required

P/N Sample: RF CVBS 01AGT 20-27SX CR CD5 F7 N

CVBS - Bayonet Connector with protected mating ramps

In-Line Receptacle (01) with Backshell Class (AG2 - G2)

These classes of connectors are all suitable for heat shrink tubing applications. Two piece backshell includes nut for shell tightening. Internal serration prevents backshell rotation and allows easy assembling after contacts are inserted.

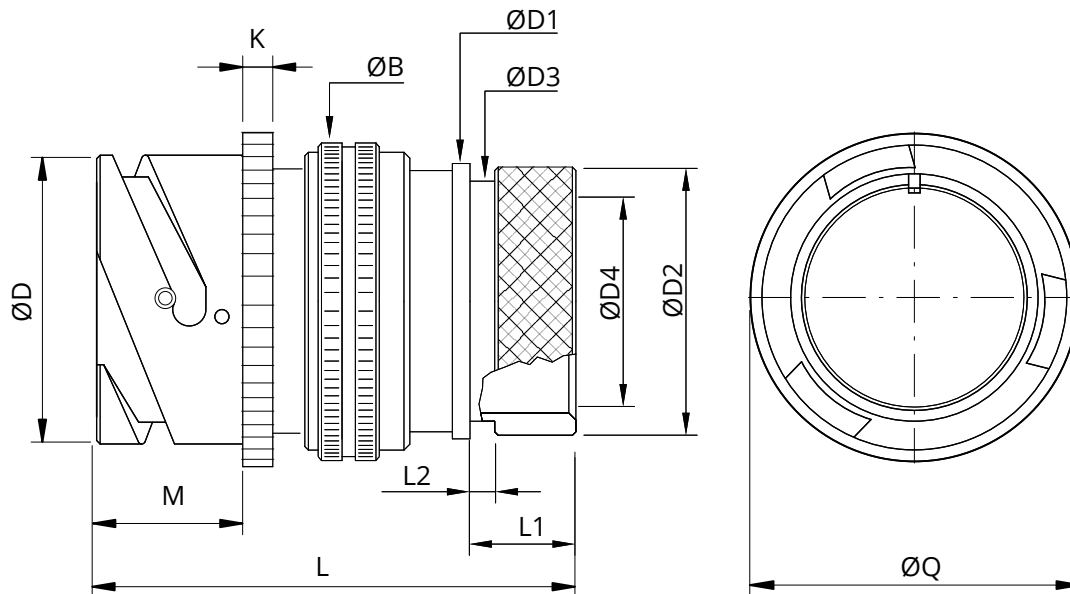

Shell size	$\varnothing D$ +0 -0.15	$\varnothing Q$ Max	$\varnothing B$ ± 0.2	$\varnothing D1$ ± 0.2	$\varnothing D2$ ± 0.2	$\varnothing D3$ ± 0.2	$\varnothing D4$ ± 0.2	L	L1 ± 0.2	L2 ± 0.2	K ± 0.2	M ± 0.2
10SL	18.2	22	22.5	17	15.5	13.3	8.6	48	11.7	3.5	2.8	14.2
14S	24.6	29	26	20.1	19.1	17	10.8	48	11.7	3.5	3.2	14.5
16S	27.4	31	29	23.5	23.9	21.9	14	48	11.7	3.5	3.2	14.2
16	27.4	31	29	23.5	23.9	21.9	14	60	11.5	3.5	3.2	19
18	30.8	34	33.4	26.5	23.9	21.9	14.8	65	11.5	3.5	4	19
20	34.2	37	37	30.2	29.6	26.2	19.3	65	12.4	3.5	4	19
22	37.4	40	41	33.6	29.6	26.2	22.5	65	12.7	3.5	4	19.7
24	40.9	44	45.9	36.1	37.8	34.5	28	65	12.7	3.5	4	20.6
28	46.7	49.5	51	41.4	37.8	34.5	28	65	12.7	3.5	4	20.6
32	53.4	56	58	50	47.8	43.4	34.8	70	15.2	3.5	4	22.2
36	59.6	62.5	60.5	56	47.7	43.4	38.7	75	15.2	3.5	4	22.2
40	65.5	68.5	69	62.4	57.6	52.4	48.2	77	15.2	3.5	4	22.2

Dimensions in mm

Dimension "L" can be different from the value indicated according to backshells accessories, wires size and some special insert configurations.

CVBS - Bayonet Connector with protected mating ramps



Series Code Shell Material Type Shell Class Connector Class

Shell finish

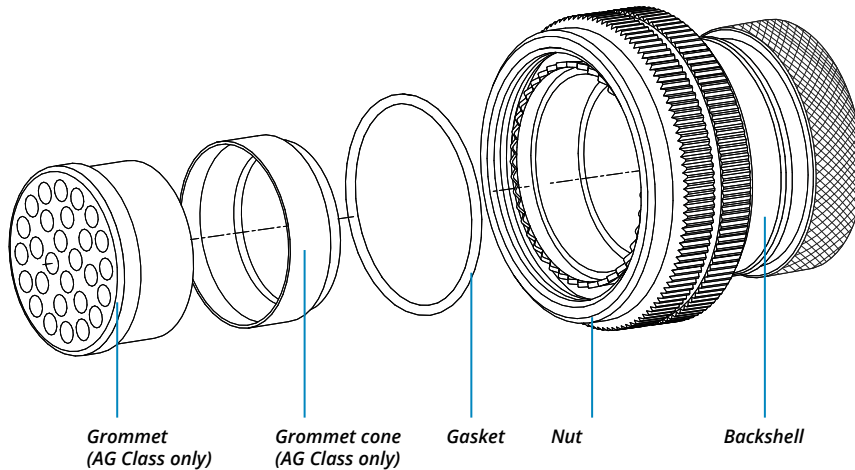

The accessories for this class are not always available in stock for all sizes; we suggest you consult our Sales Office for availability

RF	Insulating material	-	Chloroprene rubber	S	Contact Gender	S	Socket contacts		
		V	Fluoride rubber			P	Pin contacts		
		S	Silicone rubber						
		RF	Fire resistant rubber						
CVBS	Series Code	CVBS	Bayonet Connector with protected mating ramps	X	Polarization Code**		Alternate Positions		
[]	Shell Material	-	Aluminum	CR	Contact Termination	-	Solder contacts		
						CR	Crimp contacts		
						LC	Less contacts		
01	Shell Type	01	In-line receptacle	CD5	Contact Plating	-	Silver plating		
						CD5	Gold plating		
G2	Connector Class	AG2	With waterproof O-ring (IP67***)	F7	Shell finish	F5	Electroless nickel (*)		
		G2	With waterproof O-ring and grommet (IP67***)#			F7	Black epoxy varnish (*)		
								F16	CCF - Black passivation (*) - conductive
								F26	hard anodization (*)
T	Connector Modification**	T	With plastic caps	N	Modification Code**	N	Consult our sales office		
						S			
20-27	Insert Arrangement		Size - Type						

*** Protection degree: IP 67 (only in the mating area with mated connectors) according to EN 60529 (*) RoHS compliance (***) If required

P/N Sample: RF CVBS 01G2T 20-27SX CR CD5 F7 N

(#) In some sizes the grommet cone is not needed

CVBS - Bayonet Connector with protected mating ramps

In-Line Receptacle (01) with Backshell Class (ASB1 - SB1)

Backshell for multicore jacketed shielded cables, provided with MS 3057...C type Cable-Clamp. (for jacketed cable)
Also available versions for over/under dimensioned cables.

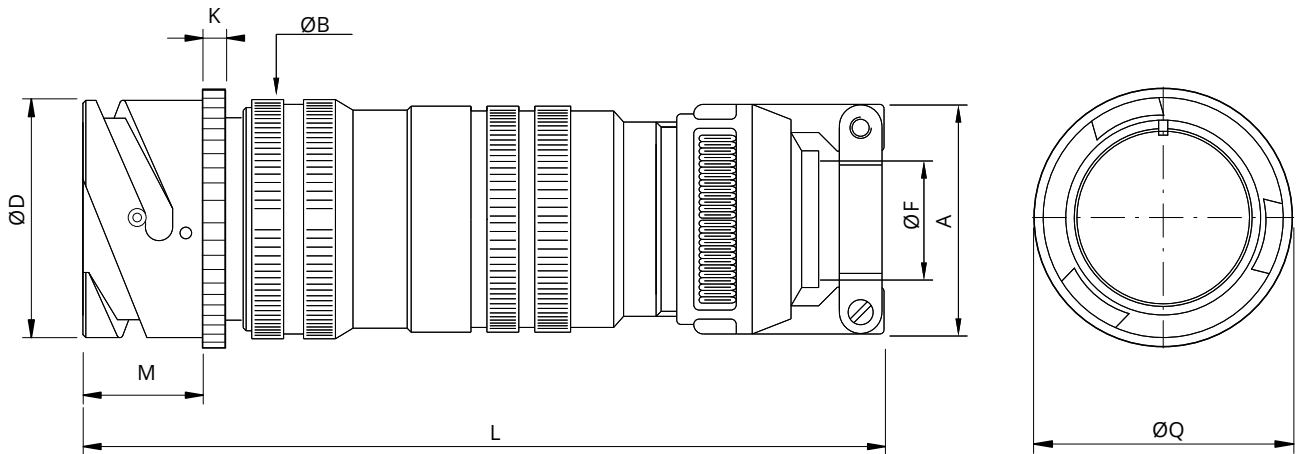

Shell size	ØD +0 -0.15	ØQ Max	ØB ±0.2	K ±0.2	L	M ±0.2	A ±0.2	ØF cable dimension	
								Min	Max
10SL	18.2	22	20	2.8	99	14.2	23	2.4	7.9
14S	24.6	29	24	3.2	99	14.5	26	5.8	11.2
16S	27.4	31	27	3.2	100	14.2	28.5	8	13.5
16	27.4	31	27	3.2	118	19	28.5	8	13.5
18	30.8	34	32	4	124	19	32	9.6	15.9
20	34.2	37	35	4	124	19	37.5	11.3	19
22	37.4	40	37	4	124	19.7	37.5	11.3	19
24	40.9	44	42	4	135	20.6	43.5	15.5	23.8
28	46.7	49.5	45	4	138	20.6	43.5	15.5	23.8
32	53.4	56	50	4	146	22.2	54	23.4	31.8
36	59.6	62.5	58	4	150	22.2	58	25.4	35
40	65.5	68.5	63.8	4	154	22.2	63.5	30	41.3

Dimensions in mm

Dimension "L" can be different from the value indicated according to backshells accessories, wires size and some special insert configurations.

CVBS - Bayonet Connector with protected mating ramps

RF	CVBS		01	ASB1	T	20-27	S	X		CR	CD5	F7		N
Series Code	Shell Material	Shell Type	Connector Class									Shell finish		

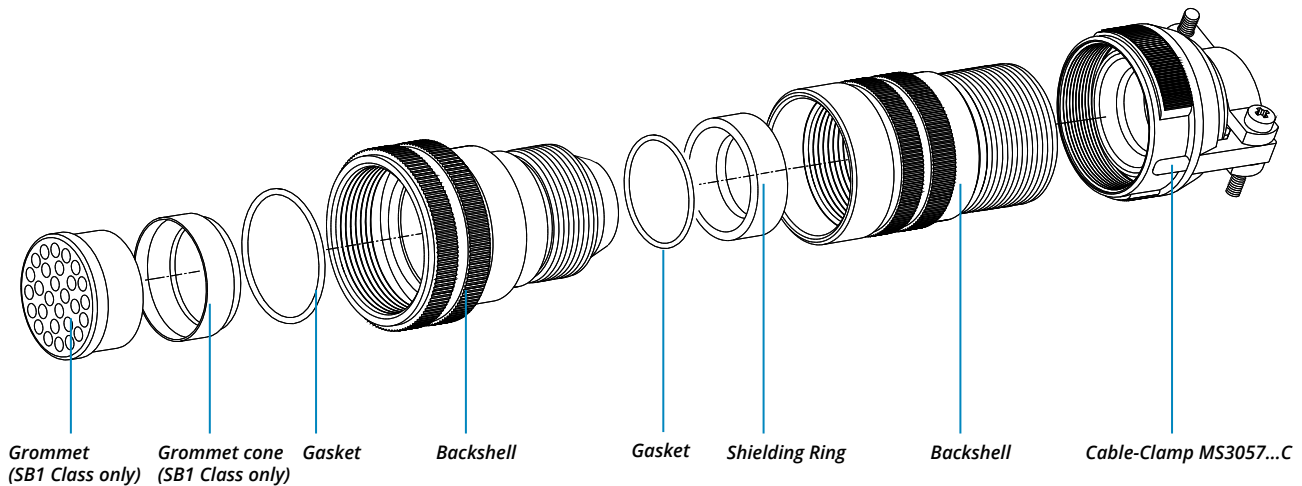

The accessories for this class are not always available in stock for all sizes; we suggest you consult our Sales Office for availability

RF	Insulating material	-	Chloroprene rubber	S	Contact Gender	S	Socket contacts	
		V	Fluoride rubber			P	Pin contacts	
		S	Silicone rubber		X	Polarization Code**	Alternate Positions	
		RF	Fire resistant rubber					
CVBS	Series Code	CVBS	Bayonet Connector with protected mating ramps	CR	Contact Termination	-	Solder contacts	
	Shell Material	-	Aluminum			CR	Crimp contacts	
		LC	Less contacts					
01	Shell Type	01	In-line receptacle	CD5	Contact Plating	-	Silver plating	
ASB1	Connector Class	ASB1	with waterproof O-ring (IP67)			CD5	Gold plating	
		SB1	with waterproof O-ring and grommet (IP67)#			F5	Electroless nickel (*)	
T	Connector Modification**	T	With plastic caps	F7	Shell finish	F7	Black epoxy varnish (*)	
20-27	Insert Arrangement		Size - Type			F16	CCF - Black passivation (*) - conductive	
						F26	hard anodization (*)	
						N	Consult our sales office	
		S		N	Modification Code**	S	Consult our sales office	

P/N Sample: RF CVBS 01SB1T 20-27SX CR CD5 F7 N

(*) RoHS compliance

(**) If required

(#) In some sizes the grommet cone is not needed

CVBS - Bayonet Connector with protected mating ramps

In-Line Receptacle (01) with Backshell Class (AGV - GV)

These classes of connectors are provided with backshell for shield hose and heat shrink tubing termination. It comes complete with conical protection spring, also suitable for thin shield braid.

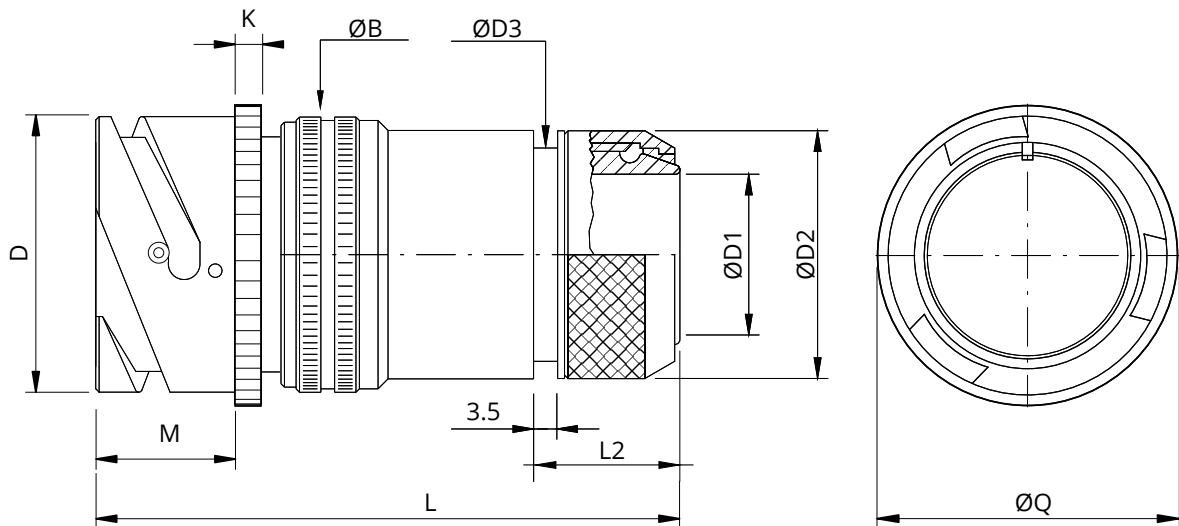

Shell size	ØD +0 -0.15	ØQ Max	ØB ±0.2	ØD1 ±0.2	ØD2 ±0.2	ØD3 ±0.2	L	L2 ±0.2	K ±0.2	M ±0.2
10SL	18.2	22	20	8.6	18.5	16.3	65	18	2.8	14.2
14S	24.6	29	24	10.6	22	20	65	17.6	3.2	14.5
16S	27.4	31	27	10.4	25	23	65	20.7	3.2	14.2
16	27.4	31	27	13.5	25	23	74	20.8	3.2	19
18	30.8	34	30	14.5	28	24.5	75	20.8	4	19
20	34.2	37	32	18.4	32	28.5	75	20.8	4	19
22	37.4	40	37	20.7	34	30.5	75	20.8	4	19.7
24	40.9	44	40	24.6	38.5	34.5	81	20.7	4	20.6
28	46.7	49.5	46	25	40	36	81	21.8	4	20.6
32	53.4	56	52	33.3	48	44	83	20.7	4	22.2
36	59.6	62.5	58	38.5	55	51	83	20.7	4	22.2
40	65.5	68.5	63.8	46	62	58	83	21.8	4	22.2

Dimensions in mm

Dimension "L" can be different from the value indicated according to backshells accessories, wires size and some special insert configurations.

CVBS - Bayonet Connector with protected mating ramps



Series Shell Shell Connector
Code Material Type Class

Shell
finish

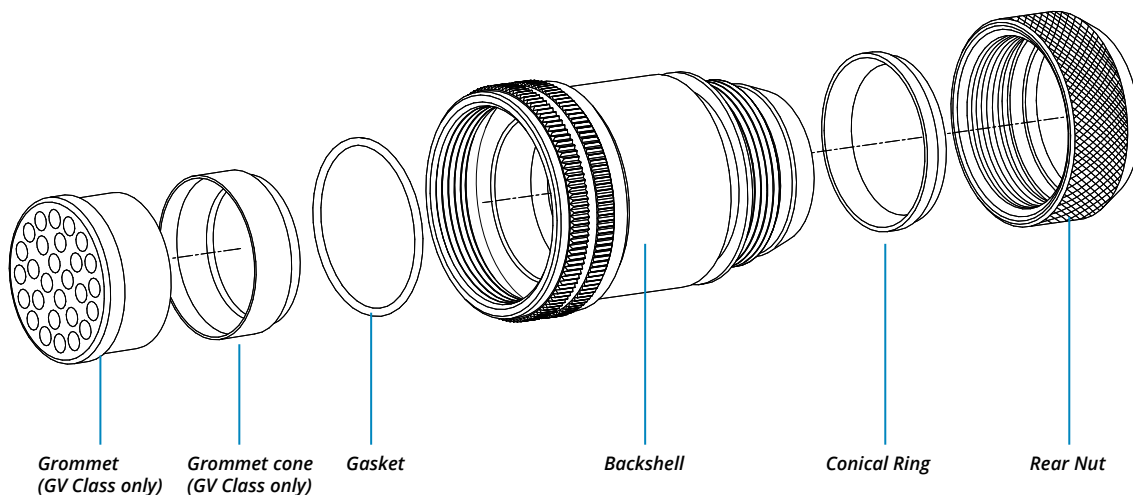

The accessories for this class are not always available in stock for all sizes; we suggest you consult our Sales Office for availability

RF	Insulating material	-	Chloroprene rubber
		V	Fluoride rubber
		S	Silicone rubber
		RF	Fire resistant rubber
CVBS	Series Code	CVBS	Bayonet Connector with protected mating ramps
	Shell Material	-	Aluminum
01	Shell Type	01	In-line receptacle
GV	Connector Class	AGV	With waterproof O-ring (IP67***)
		GV	with waterproof O-ring and grommet (IP67***)
20-27	Insert Arrangement		Size - Type
S	Contact Gender	S	Socket contacts
		P	Pin contacts

X	Polarization Code**		Alternate Positions
CR	Contact Termination	-	Solder contacts
		CR	Crimp contacts
		LC	Less contacts
CD5	Contact Plating	-	Silver plating
		CD5	Gold plating
		F5	Electroless nickel (*)
		F7	Black epoxy varnish (*)
F7	Shell finish	F16	CCF - Black passivation (*) - conductive
		F26	hard anodization (*)
N	Modification Code**	N	Consult our sales office
		S	

*** Protection degree: IP 67 (only in the mating area with mated connectors) according to EN 60529 (*) RoHS compliance (***) If required

P/N Sample: RF CVBS 01GVT 20-27SX CR CD5 F7 N

CVBS - Bayonet Connector with protected mating ramps

In-Line Receptacle (01) with Backshell Class (SB)

These classes of connectors are provided with backshell for shield hose and heat shrink tubing termination. It comes complete with conical protection spring, also suitable for thin shield braid. Two piece backshell includes nut for shell tightening. Internal serration prevents backshell rotation and allows easy assembling after contacts are inserted.

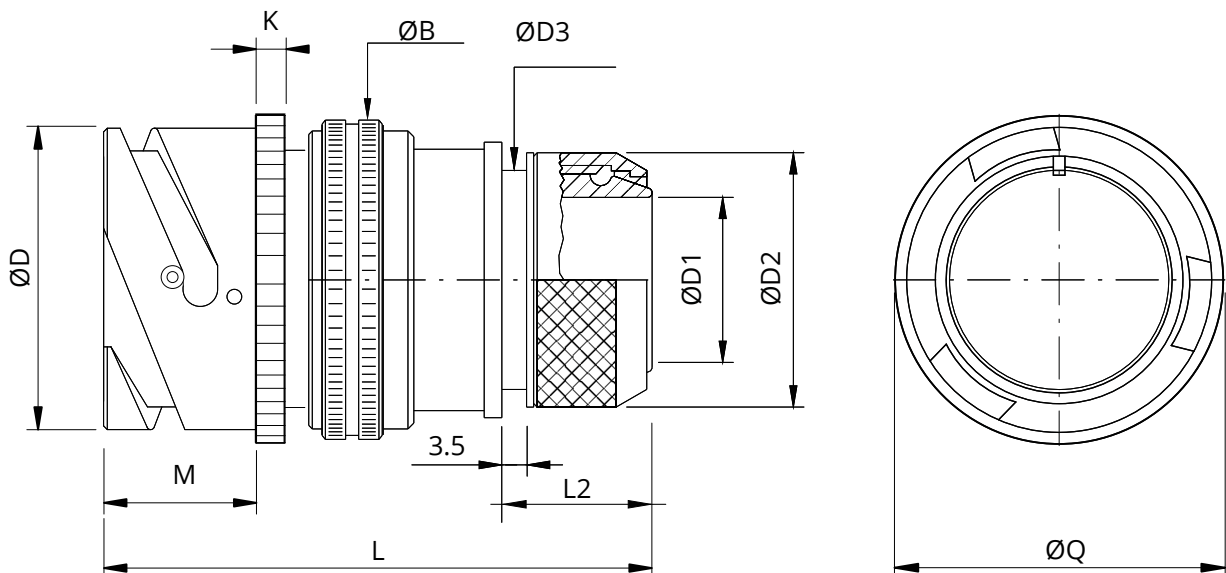

Shell size	$\varnothing D$ +0 -0.15	$\varnothing Q$ Max	$\varnothing B$ ± 0.2	$\varnothing D1$ ± 0.2	$\varnothing D2$ ± 0.2	$\varnothing D3$ ± 0.2	L	L2 ± 0.2	K ± 0.2	M ± 0.2
10SL	18.2	22	22.5	8.6	18.5	16.3	60	18	2.8	14.2
14S	24.6	29	26.1	10.6	22	20	60	17.6	3.2	14.5
16S	27.4	31	29	10.4	25	23	60	20.7	3.2	14.2
16	27.4	31	29	13.5	25	23	65	20.8	3.2	19
18	30.8	34	33.5	14.5	28	24.5	69	20.8	4	19
20	34.2	37	37	18.4	32	28.5	70	20.8	4	19
22	37.4	40	41	20.7	34	30.5	70	20.8	4	19.7
24	40.9	44	46	24.6	38.5	34.5	73	20.7	4	20.6
28	46.7	49.5	51	25	40	36	74	21.8	4	20.6
32	53.4	56	58	33.3	48	44	75	20.7	4	22.2
36	59.6	62.5	61	38.5	55	51	75	20.7	4	22.2
40	65.5	68.5	69	46	62	58	75	21.8	4	22.2

Dimensions in mm

Dimension "L" can be different from the value indicated according to backshells accessories, wires size and some special insert configurations.

CVBS - Bayonet Connector with protected mating ramps



Series Shell **Shell** **Connector**
Code **Material** **Type** **Class**

Shell
finish

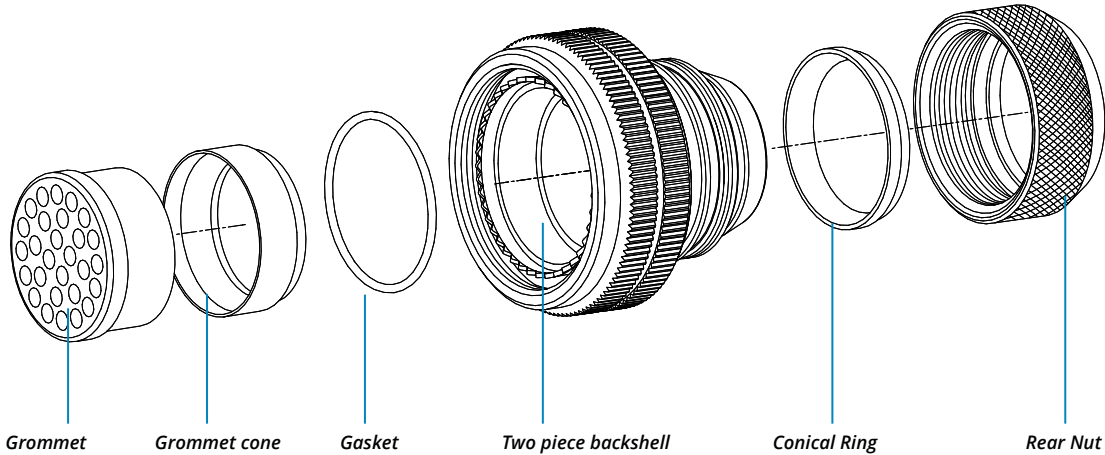

The accessories for this class are not always available in stock for all sizes; we suggest you consult our Sales Office for availability

RF	Insulating material	-	Chloroprene rubber	S	Contact Gender	S	Socket contacts
		V	Fluoride rubber			P	Pin contacts
		S	Silicone rubber	X	Polarization Code**		Alternate Positions
		RF	Fire resistant rubber				
CVBS	Series Code	CVBS	Bayonet Connector with protected mating ramps	CR	Contact Termination	-	Solder contacts
[]	Shell Material	-	Aluminum			CR	Crimp contacts
						LC	Less contacts
01	Shell Type	01	In-line receptacle	CD5	Contact Plating	-	Silver plating
						CD5	Gold plating
SB	Connector Class	SB	With waterproof O-ring and grommet (IP67***)#	F7	Shell finish	F5	Electroless nickel (*)
						F7	Black epoxy varnish (*)
						F16	CCF - Black passivation (*) - conductive
T	Connector Modification**	T	With plastic caps			F26	hard anodization (*)
20-27	Insert Arrangement		Size - Type	N	Modification Code**	N	Consult our sales office
						S	

*** Protection degree: IP 67 (only in the mating area with mated connectors) according to EN 60529 (*) RoHS compliance (***) If required

P/N Sample: RF CVBS 01SBT 20-27SX CR CD5 F7 N

(#) In some sizes the grommet cone is not needed

CVBS - Bayonet Connector with protected mating ramps

Rear Mounting Receptacle (07/07R) unable to accept Rear Accessories

Mounting is made by a hexagonal coupling nut. It is supplied with sealing gasket to guarantee waterproof protection.

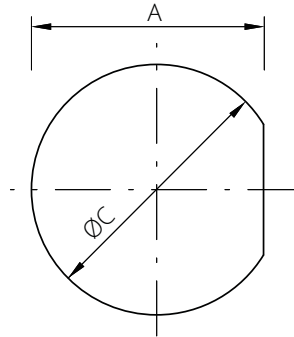

Panel cut out

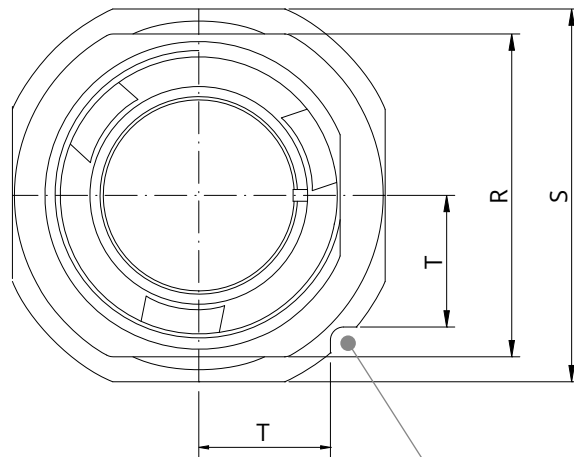
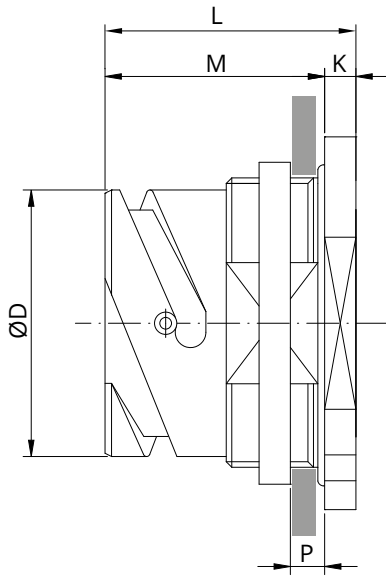

If required the nut can be lock with optional screws

Shell size	ØD	K ±0.1	M ±0.2	L	R ±0.1	S ±0.25	T ±0.1	P Panel Thickness		ØC - 0 + 0.25	A ±0.2
								Min	Max		
10SL**	18.2	4	24.5	28.5	27	31.8	11.2	2.4	5.2	22.4	21
14S	24.6	4.8	26.8	31.6	33	41.3	14.6	2.4	7.5	28.75	27.4
16S	27.4	4.8	26.8	31.6	38	44.4	15.7	2.4	7.5	31.95	30.95
16**	27.4	4.8	32.1	36.9	38	44.4	15.7	2.4	7.5	31.95	30.95
18	30.8	4.8	33.7	38.5	39.7	47.6	16.8	2.4	9	35.1	33.75
20	34.2	4.8	33.7	38.5	44	50.8	18	2.4	8.1	38.3	36.85
22	37.4	4.8	33.7	38.5	46	54.2	20.2	2.4	9.1	41.45	40.05
24	40.9	4.8	33.7	38.5	50.8	57.2	20.2	2.4	9.1	44.65	43.35
28	46.7	5.6	35.2	40.8	55	63.5	22.5	2.4	8.5	51	49.55
32	53.4	5.6	35.2	40.8	62	69.8	24.7	2.4	6.5	57.35	55.95
36	59.6	5.6	35.2	40.8	71	76.2	26.9	2.4	8.3	63.7	62.35
40	65.5	5.6	35.2	40.8	75	83.5	29.6	2.4	8.3	70.05	68.55

Dimensions in mm

** On request (please consult our Sales Office)

Dimension "L" can be different from the value indicated according to backshells accessories, wires size and some special insert configurations.

CVBS - Bayonet Connector with protected mating ramps



Series Shell Shell
Code Material Type

Shell
finish

RF	Insulating material	-	Chloroprene rubber
		V	Fluoride rubber
		S	Silicone rubber
		RF	Fire resistant rubber
CVBS	Series Code	CVBS	Bayonet Connector with protected mating ramps
[]	Shell Material	-	Aluminum
07	Shell Type	07	Rear mounting Receptacle, unable to accept rear accessories. Mounting is made by a hexagonal coupling nut. It is supplied with sealing gasket to guarantee waterproof protection.
		07R	Rear mounting Receptacle connector environmental seal, unable to accept rear accessories. Mounting is made by a hexagonal coupling nut. It is supplied with sealing gasket to guarantee waterproof protection.
T	Connector Modification**	T	With plastic caps
20-27	Insert Arrangement		Size - Type
S	Contact Gender	S	Socket contacts
		P	Pin contacts
X	Polarization Code**		Alternate Positions
CR	Contact Termination	-	Solder contacts
		CR	Crimp contacts
		LC	Less contacts
CD5	Contact Plating	-	Silver plating
		CD5	Gold plating
F7	Shell finish	F5	Electroless nickel (*)
		F7	Black epoxy varnish (*)
		F16	CCF - Black passivation (*) - conductive
		F26	hard anodization (*)
N	Modification Code**	N	Consult our sales office
		S	

P/N Sample: RF CVBS 07T 20-27SX CR CD5 F7 N

(*) RoHS compliance

(**) If required

CVBS - Bayonet Connector with protected mating ramps

Rear Mounting Receptacle (070) without Accessories (To be purchased separately)

Mounting is made by a hexagonal coupling nut. It is supplied with sealing gasket to guarantee waterproof protection.

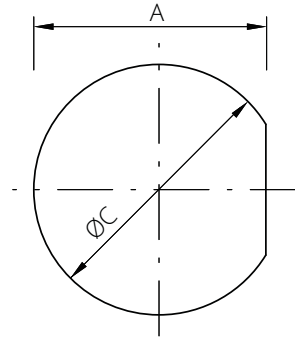

Panel cut out

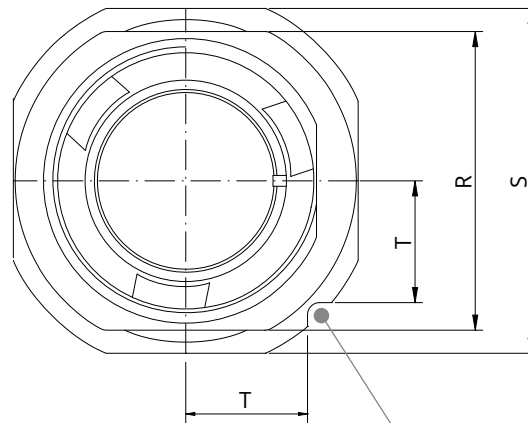
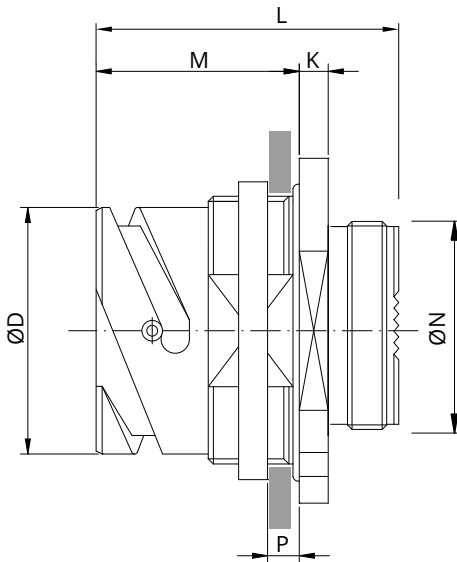

If required the nut can be lock with optional screws

Shell size	ØD	K ±0.1	M ±0.2	L	N Backshell Thread in inches	R ±0.1	S ±0.25	T ±0.1	P Panel Thickness		ØC - 0 + 0.25	A ±0.2
									Min	Max		
10SL**	18.2	4	24.5	36.2	5/8"-24 UNEF	27	31.8	11.2	2.4	5.2	22.4	21
14S	24.6	4.8	26.8	39.8	3/4"-20 UNEF	33	41.3	14.6	2.4	7.5	28.75	27.4
16S	27.4	4.8	26.8	40.1	7/8"-20 UNEF	38	44.4	15.7	2.4	7.5	31.95	30.95
16**	27.4	4.8	32.1	48.9	7/8"-20 UNEF	38	44.4	15.7	2.4	7.5	31.95	30.95
18	30.8	4.8	33.7	49.3	1"-20 UNEF	39.7	47.6	16.8	2.4	9	35.1	33.75
20	34.2	4.8	33.7	50.2	1" 1/8-18 UNEF	44	50.8	18	2.4	8.1	38.3	36.85
22	37.4	4.8	33.7	50.5	1" 1/4-18 UNEF	46	54.2	20.2	2.4	9.1	41.45	40.05
24	40.9	4.8	33.7	49.3	1" 3/8-18 UNEF	50.8	57.2	20.2	2.4	9.1	44.65	43.35
28	46.7	5.6	35.2	51.9	1" 5/8-18 UNEF	55	63.5	22.5	2.4	8.5	51	49.55
32	53.4	5.6	35.2	51.9	1" 7/8-16 UN	62	69.8	24.7	2.4	6.5	57.35	55.95
36	59.6	5.6	35.2	51.9	2" 1/16-16 UN	71	76.2	26.9	2.4	8.3	63.7	62.35
40	65.5	5.6	35.2	51.9	2" 5/16-16 UNS	75	83.5	29.6	2.4	8.3	70.05	68.55

Dimensions in mm

** On request (please consult our Sales Office)

Dimension "L" can be different from the value indicated according to backshells accessories, wires size and some special insert configurations.

CVBS - Bayonet Connector with protected mating ramps

RF	CVBS		070		T	20-27	S	X		CR	CD5	F7	N
Series Code		Shell Material Type	Shell Type		Connector Modification**	Insert Arrangement	Contact Gender	Polarization Code**	Contact Termination	Contact Plating	Shell finish	Modification Code**	

RF	Insulating material	-	Chloroprene rubber
		V	Fluoride rubber
		S	Silicone rubber
		RF	Fire resistant rubber
CVBS	Series Code	CVBS	Bayonet Connector with protected mating ramps
	Shell Material	-	Aluminum
070	Shell Type	070	Rear mounting Receptacle, without accessories. Mounting is made by a hexagonal coupling nut. It is supplied with sealing gasket to guarantee waterproof protection.
T	Connector Modification**	T	With plastic caps
20-27	Insert Arrangement		Size - Type
S	Contact Gender	S	Socket contacts
		P	Pin contacts
X	Polarization Code**		Alternate Positions
CR	Contact Termination	-	Solder contacts
		CR	Crimp contacts
		LC	Less contacts
CD5	Contact Plating	-	Silver plating
		CD5	Gold plating
		F5	Electroless nickel (*)
F7	Shell finish	F7	Black epoxy varnish (*)
		F16	CCF - Black passivation (*) - conductive
		F26	hard anodization (*)
N	Modification Code**	N	Consult our sales office
		S	

P/N Sample: RF CVBS 070T 20-27SX CR CD5 F7 N

(*) RoHS compliance

(**) If required

CVBS - Bayonet Connector with protected mating ramps

Plug Connector (06) with Backshell Class (A - DA - RA)

Connector with backshell provided with an external thread suitable for MS3057...A or C type Cable-Clamps (to be ordered separately).

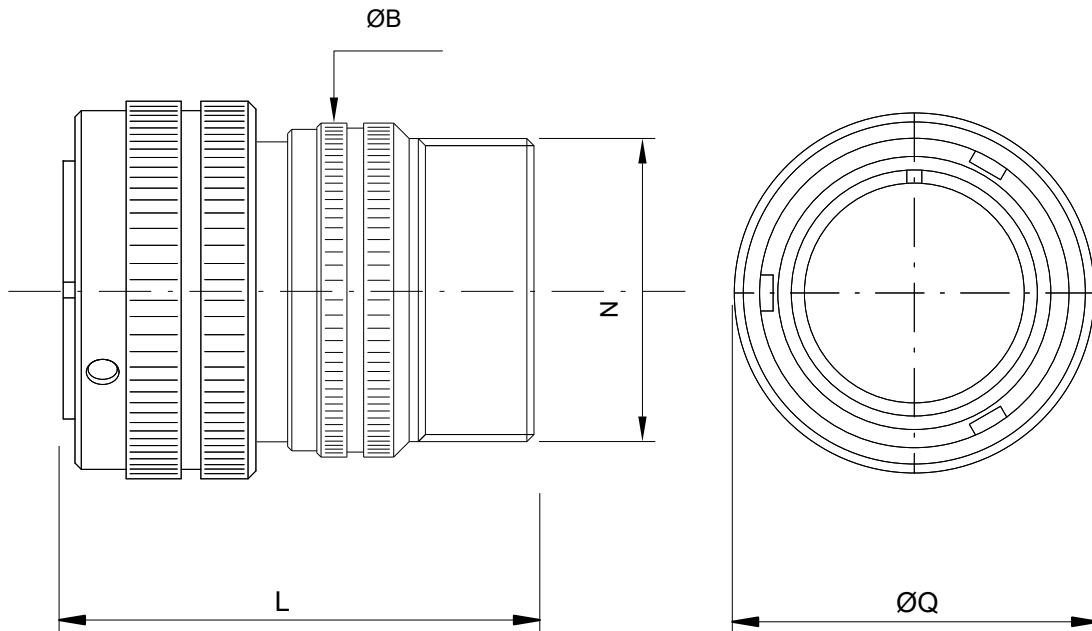

Shell size	ØQ ±0.2	ØB ±0.2	L max	N Backshell Thread in inches
10SL	23.3	20	36	5/8"-24 UNEF
14S	29.5	24	43	3/4"-20 UNEF
16S	33	27	43	7/8"-20 UNEF
16	33	27	49	7/8"-20 UNEF
18	37	30	52	1"-20 UNEF
20	41	32	52.5	1" 3/16-18 UNEF
22	43	37	55	1" 3/16-18 UNEF
24	48	40	55	1" 7/16-18 UNEF
28	53	45	62	1" 7/16-18 UNEF
32	60	52	62	1" 3/4-18 UNS
36	66.2	58	62	2"-18 UNS
40	72.4	63.8	64	2"1/4-16 UN

Dimensions in mm

Dimension "L" can be different from the value indicated according to backshells accessories, wires size and some special insert configurations.

CVBS - Bayonet Connector with protected mating ramps

RF	CVBS		06	DA	T	20-27	S	X		CR	CD5	F7		N
Series Code	Shell Material	Shell Type	Connector Class									Shell finish		

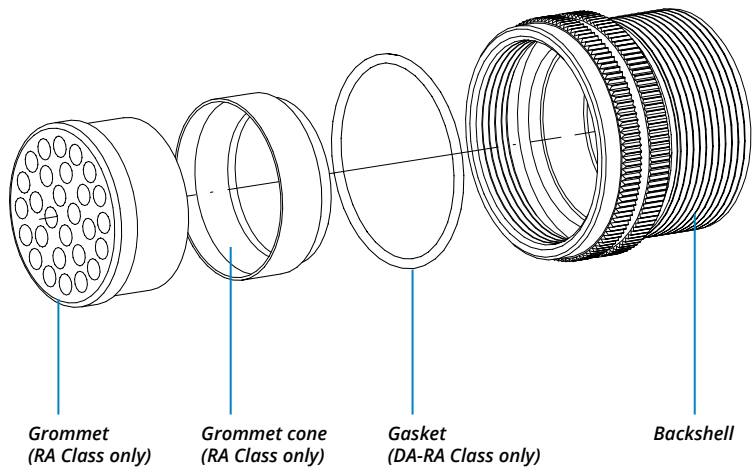

RF	Insulating material	-	Chloroprene rubber	S	Contact Gender	S	Socket contacts
		V	Fluoride rubber			P	Pin contacts
		S	Silicone rubber				
		RF	Fire resistant rubber				
CVBS	Series Code	CVBS	Bayonet Connector with protected mating ramps	X	Polarization Code**		Alternate Positions
	Shell Material	-	Aluminum	CR	Contact Termination	-	Solder contacts
						CR	Crimp contacts
						LC	Less contacts
06	Shell Type	06	Plug Connector	CD5	Contact Plating	-	Silver plating
						F5	Electroless nickel (*)
DA	Connector Class	A	non watertight	F7	Shell finish	F7	Black epoxy varnish (*)
		DA	with waterproof O-ring (IP67***)			F16	CCF - Black passivation (*) - conductive
		RA	with waterproof O-ring and grommet (IP67***)			F26	hard anodization (*)
T	Connector Modification**	T	With plastic caps	N	Modification Code**	N	Consult our sales office
						S	
20-27	Insert Arrangement		Size - Type				

*** Protection degree: IP 67 (only in the mating area with mated connectors) according to EN 60529 (*) RoHS compliance (**) If required

P/N Sample: RF CVBS 06DAT 20-27SX CR CD5 F7 N

CVBS - Bayonet Connector with protected mating ramps

Plug Connector (06) with Backshell Class (LA - LDA - LRA)

Connector with Llong backshell provided with an external thread suitable for MS3057...A or C type Cable-Clamps (to be ordered separately).

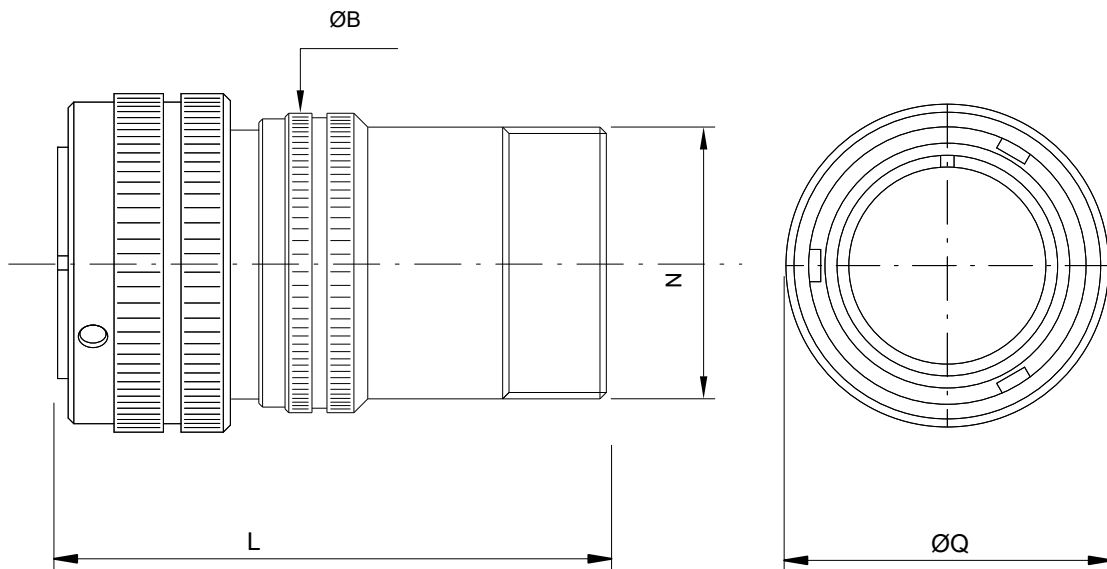

Shell size	$\text{Ø}Q$ ± 0.2	$\text{Ø}B$ ± 0.2	L max	N Backshell Thread in inches
10SL	23.3	20	68	5/8"-24 UNEF
14S	29.5	24	68	3/4"-20 UNEF
16S	33	27	68	7/8"-20 UNEF
16	33	27	78.5	7/8"-20 UNEF
18	37	30	78.5	1"-20 UNEF
20	41	32	79	1" 3/16-18 UNEF
22	43	37	80.5	1" 3/16-18 UNEF
24	48	40	81	1" 7/16-18 UNEF
28	53	45	81	1" 7/16-18 UNEF
32	60	52	95.5	1" 3/4-18 UNS
36	66.2	58	95.5	2"-18 UNS
40	72.4	63.8	96.5	2" 1/4-16 UN

Dimensions in mm

Dimension "L" can be different from the value indicated according to backshells accessories, wires size and some special insert configurations.

CVBS - Bayonet Connector with protected mating ramps

RF	CVBS		06	LDA	T	20-27	S	X		CR	CD5	F7		N
Series Code	Shell Material	Shell Type	Connector Class									Shell finish		

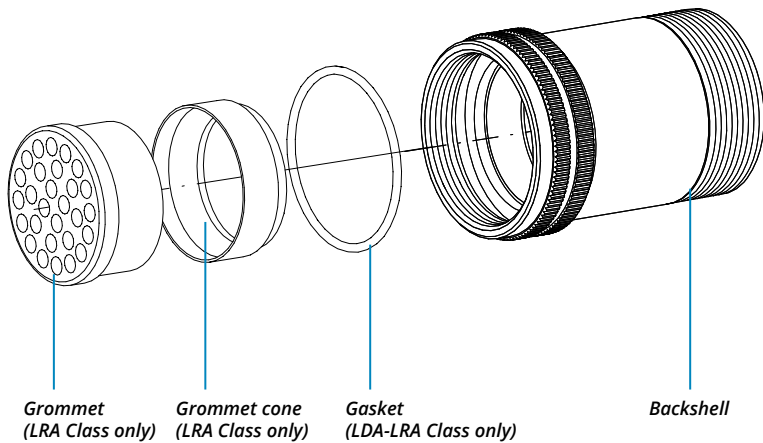

RF	Insulating material	-	Chloroprene rubber
		V	Fluoride rubber
		S	Silicone rubber
		RF	Fire resistant rubber
CVBS	Series Code	CVBS	Bayonet Connector with protected mating ramps
	Shell Material	-	Aluminum
06	Shell Type	06	Plug Connector
LDA	Connector Class	LA	non watertight
		LDA	with waterproof O-ring (IP67***)
		LRA	with waterproof O-ring and grommet (IP67***)
T	Connector Modification**	T	With plastic caps
20-27	Insert Arrangement		Size - Type

S	Contact Gender	S	Socket contacts
		P	Pin contacts
X	Polarization Code**		Alternate Positions
CR	Contact Termination	-	Solder contacts
		CR	Crimp contacts
		LC	Less contacts
CD5	Contact Plating	-	Silver plating
		CD5	Gold plating
		F5	Electroless nickel (*)
		F7	Black epoxy varnish (*)
F7	Shell finish	F16	CCF - Black passivation (*) - conductive
		F26	hard anodization (*)
N	Modification Code**	N	Consult our sales office
		S	

*** Protection degree: IP 67 (only in the mating area with mated connectors) according to EN 60529 (*) RoHS compliance (**) If required

P/N Sample: RF CVBS 06LDAT 20-27SX CR CD5 F7 N

CVBS - Bayonet Connector with protected mating ramps

Plug Connector (06) with Backshell Class (AF - F)

Connector provided with backshell, MS3057...A type Cable-Clamp and bushing MS3420... (for single wire)

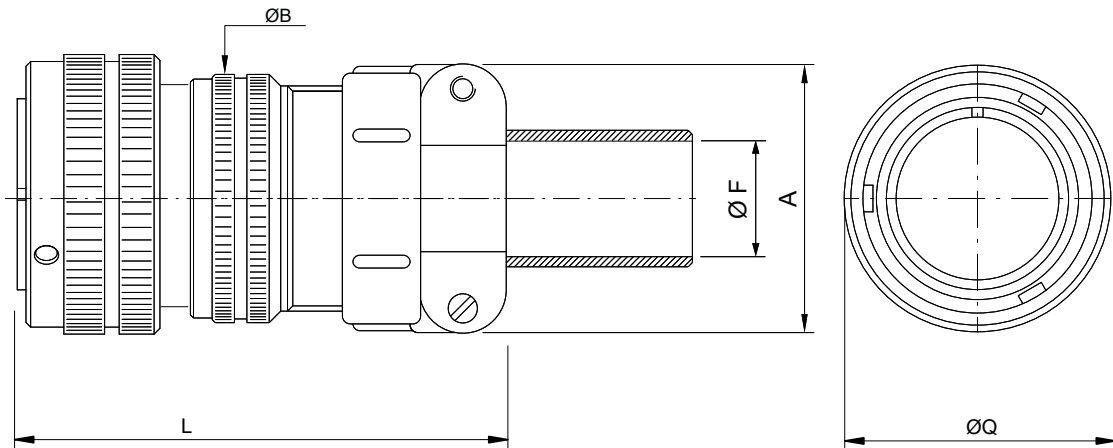

Shell size	ØQ ±0.2	L max	ØB ±0.2	A max	ØF cable max dimension
10SL	23.3	46	20	22.5	5.6
14S	29.5	55	24	28	7.9
16S	33	56.5	27	30	11
16	33	62.5	27	30	11
18	37	67.5	30	31.7	14.2
20	41	68	32	37.5	15.8
22	43	70.5	37	37.5	15.8
24	48	70.5	40	43.5	19
28	53	77.5	45	43.5	19
32	60	77.5	52	51.7	23.8
36	66.2	77.5	58	58.5	31.7
40	72.4	93	63.8	68.5	34.9

Dimensions in mm

Dimension "L" can be different from the value indicated according to backshells accessories, wires size and some special insert configurations.

CVBS - Bayonet Connector with protected mating ramps

RF	CVBS		06	AF	T	20-27	S	X		CR	CD5	F7		N
Series Code	Shell Material	Shell Type	Connector Class	Connector Class								Shell finish		

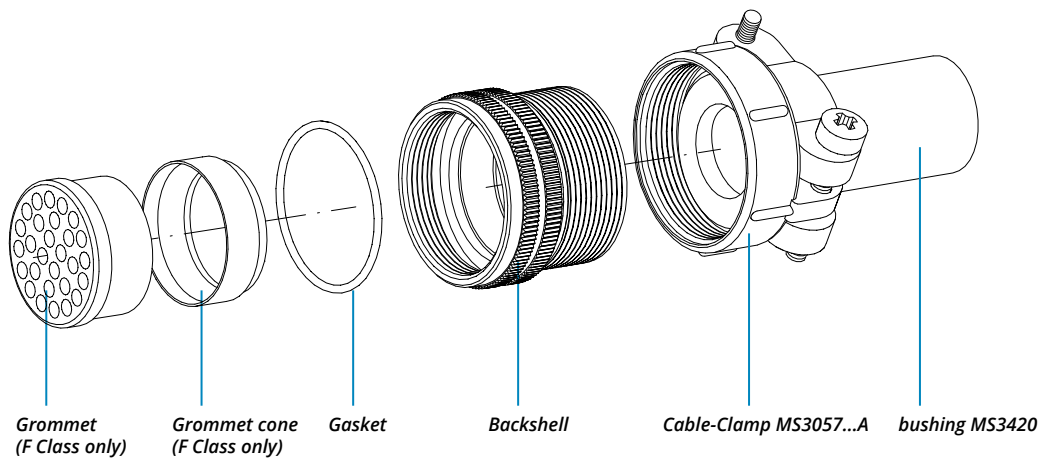

RF	Insulating material	-	Chloroprene rubber
		V	Fluoride rubber
		S	Silicone rubber
		RF	Fire resistant rubber
CVBS	Series Code	CVBS	Bayonet Connector with protected mating ramps
	Shell Material	-	Aluminum
06	Shell Type	06	Plug Connector
AF	Connector Class	AF	with waterproof O-ring (IP54)
		F	with waterproof O-ring and grommet (IP54)
T	Connector Modification**	T	With plastic caps
20-27	Insert Arrangement		Size - Type

S	Contact Gender	S	Socket contacts
		P	Pin contacts
X	Polarization Code**		Alternate Positions
CR	Contact Termination	-	Solder contacts
		CR	Crimp contacts
		LC	Less contacts
CD5	Contact Plating	-	Silver plating
		CD5	Gold plating
		F5	Electroless nickel (*)
F7	Shell finish	F7	Black epoxy varnish (*)
		F16	CCF - Black passivation (*) - conductive
		F26	hard anodization (*)
N	Modification Code**	N	Consult our sales office
		S	

P/N Sample: RF CVBS 06AFT 20-27SX CR CD5 F7 N

(*) RoHS compliance

(**) If required

CVBS - Bayonet Connector with protected mating ramps

Plug Connector (06) with Backshell Class (LAF - LF)

Connector provided with long backshell, MS3057...A type Cable-Clamp and bushing MS3420... (for single wire)

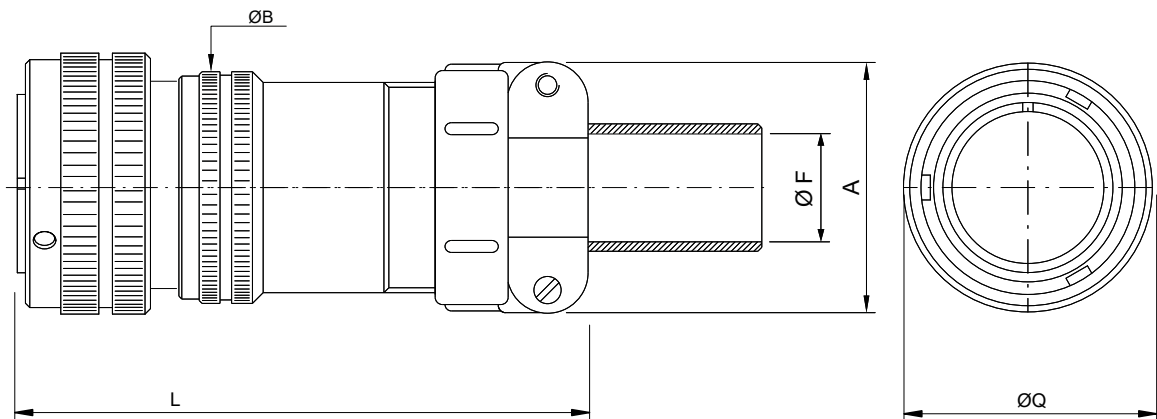

Shell size	ØQ ±0.2	L max	ØB ±0.2	A max	ØF cable max dimension
10SL	23.3	78	20	22.5	5.6
14S	29.5	80	24	28	7.9
16S	33	81.5	27	30	11
16	33	92	27	30	11
18	37	94	30	31.7	14.2
20	41	94.5	32	37.5	15.8
22	43	96	37	37.5	15.8
24	48	96.5	40	43.5	19
28	53	96.5	45	43.5	19
32	60	111	52	51.7	23.8
36	66.2	111	58	58.5	31.7
40	72.4	125.5	63.8	68.5	34.9

Dimensions in mm

Dimension "L" can be different from the value indicated according to backshells accessories, wires size and some special insert configurations.

CVBS - Bayonet Connector with protected mating ramps

RF	CVBS		06	LAF	T	20-27	S	X		CR	CD5	F7		N
Series Code	Shell Material	Shell Type	Connector Class									Shell finish		

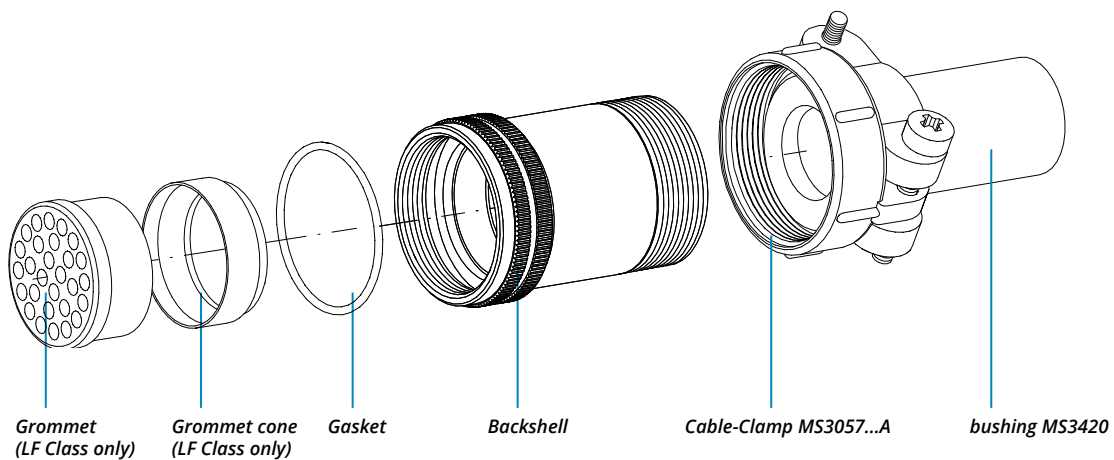

RF	Insulating material	-	Chloroprene rubber
		V	Fluoride rubber
		S	Silicone rubber
		RF	Fire resistant rubber
CVBS	Series Code	CVBS	Bayonet Connector with protected mating ramps
	Shell Material	-	Aluminum
06	Shell Type	06	Plug Connector
LAF	Connector Class	LAF	with waterproof O-ring (IP54)
		LF	with waterproof O-ring and grommet (IP54)
T	Connector Modification**	T	With plastic caps
20-27	Insert Arrangement		Size - Type

S	Contact Gender	S	Socket contacts
		P	Pin contacts
X	Polarization Code**		Alternate Positions
CR	Contact Termination	-	Solder contacts
		CR	Crimp contacts
		LC	Less contacts
CD5	Contact Plating	-	Silver plating
		CD5	Gold plating
		F5	Electroless nickel (*)
F7	Shell finish	F7	Black epoxy varnish (*)
		F16	CCF - Black passivation (*) - conductive
		F26	hard anodization (*)
N	Modification Code**	N	Consult our sales office
		S	

P/N Sample: RF CVBS 06LAFT 20-27SX CR CD5 F7 N

(*) RoHS compliance

(**) If required

CVBS - Bayonet Connector with protected mating ramps

Plug Connector (06) with Backshell Class (AC - ACF)

Connector provided with backshell, MS3057...C type Cable-Clamp (for jacketed cable)

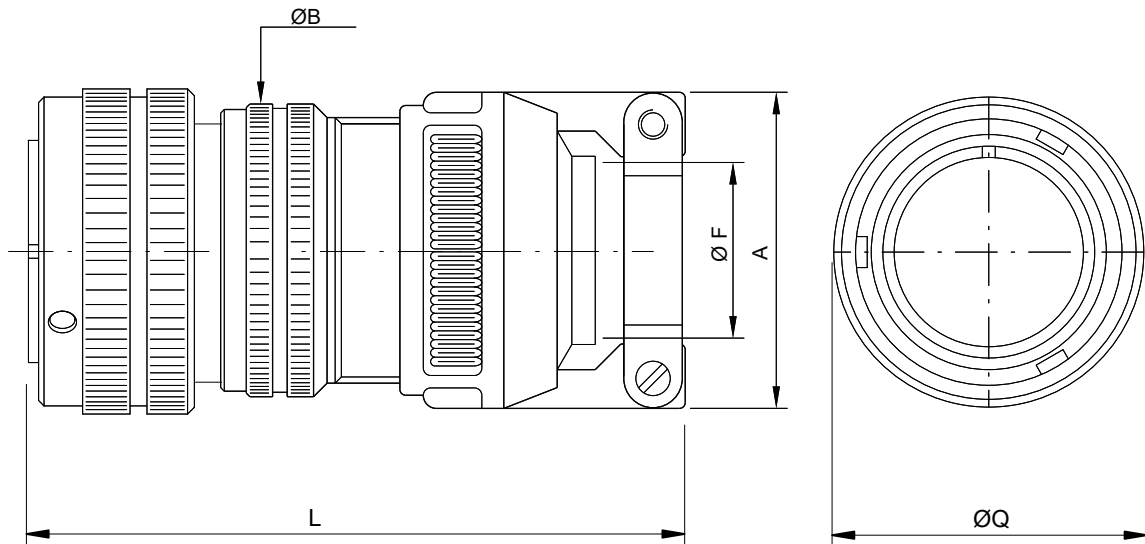

Shell size	ØQ ±0.2	L max	ØB ±0.2	A max	ØF cable dimension	
					Min	Max
10SL	23.3	60	20	23	2.4	7.9
14S	29.5	67	24	26	5.8	11.2
16S	33	68	27	28.5	8	13.5
16	33	74	27	28.5	8	13.5
18	37	79.5	30	32	9.6	15.9
20	41	79.5	32	37.5	11.3	19
22	43	81.5	37	37.5	11.3	19
24	48	88.5	40	43.5	15.5	23.8
28	53	95.5	45	43.5	15.5	23.8
32	60	100	52	54	23.4	31.8
36	66.2	104.5	58	58	25.4	35
40	72.4	108	63.8	63.5	30	41.3

Dimensions in mm

Dimension "L" can be different from the value indicated according to backshells accessories, wires size and some special insert configurations.

CVBS - Bayonet Connector with protected mating ramps



Series Code Shell Material Type Shell Class Connector Class

Shell finish

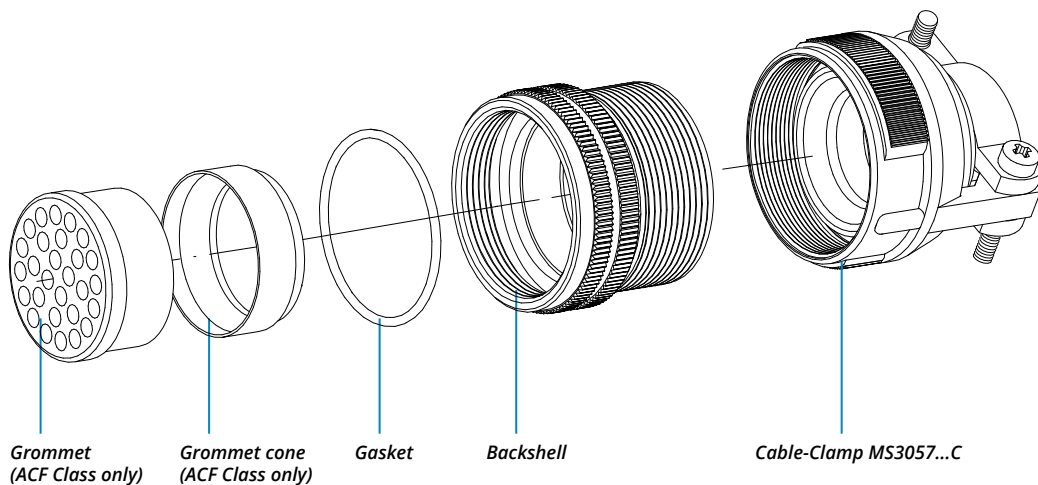

RF	Insulating material	-	Chloroprene rubber
		V	Fluoride rubber
		S	Silicone rubber
		RF	Fire resistant rubber
CVBS	Series Code	CVBS	Bayonet Connector with protected mating ramps
	Shell Material	-	Aluminum
06	Shell Type	06	Plug Connector
ACF	Connector Class	AC	with waterproof O-ring (IP67)
		ACF	with waterproof O-ring and grommet (IP67)
T	Connector Modification**	T	With plastic caps
20-27	Insert Arrangement		Size - Type

S	Contact Gender	S	Socket contacts
		P	Pin contacts
X	Polarization Code**		Alternate Positions
CR	Contact Termination	-	Solder contacts
		CR	Crimp contacts
		LC	Less contacts
CD5	Contact Plating	-	Silver plating
		CD5	Gold plating
F7	Shell finish	F5	Electroless nickel (*)
		F7	Black epoxy varnish (*)
		F16	CCF - Black passivation (*) - conductive
F26		F26	hard anodization (*)
N	Modification Code**	N	Consult our sales office
		S	

P/N Sample: RF CVBS 06ACFT 20-27SX CR CD5 F7 N

(*) RoHS compliance

(**) If required

CVBS - Bayonet Connector with protected mating ramps

Plug Connector (06) with Backshell Class (ACB)

Connector provided with backshell, MS3057...C type Cable-Clamp and bushing MS 3420A (for jacketed cable)

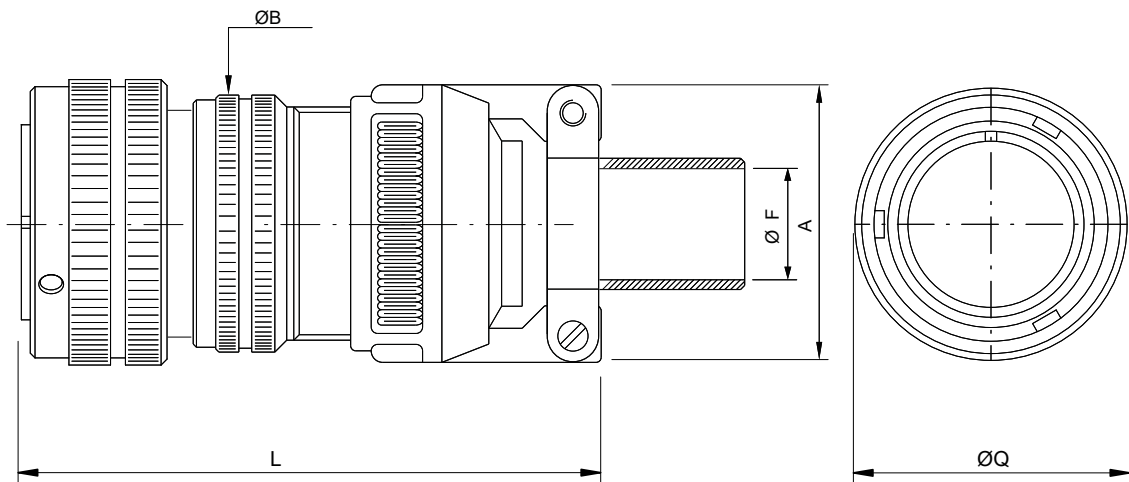

Shell size	ØQ ±0.2	L max	ØB ±0.2	A max	ØF max cable size
10SL	23.3	60	20	23	5.6
14S	29.5	67	24	26	7.9
16S	33	68	27	28.5	11.1
16	33	74	27	28.5	11.1
18	37	79.5	30	32	11.1
20	41	79.5	32	37.5	13.7
22	43	81.5	37	37.5	13.7
24	48	88.5	40	43.5	19
28	53	95.5	45	43.5	19
32	60	100	52	54	23.8
36	66.2	104.5	58	58	28.5
40	72.4	108	63.8	63.5	31.8

Dimensions in mm

Dimension "L" can be different from the value indicated according to backshells accessories, wires size and some special insert configurations.

CVBS - Bayonet Connector with protected mating ramps

RF	CVBS		06	ACB	T	20-27	S	X		CR	CD5	F7		N
Series Code	Shell Material	Shell Type	Connector Class									Shell finish		

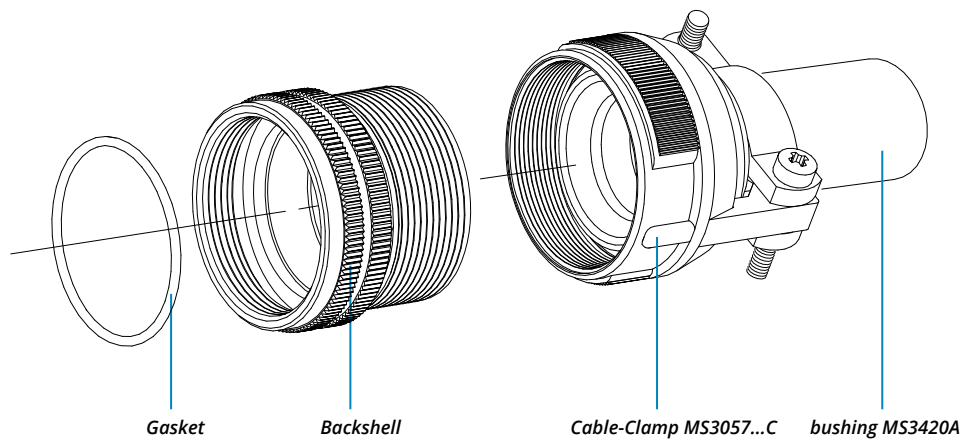

RF	Insulating material	-	Chloroprene rubber
		V	Fluoride rubber
		S	Silicone rubber
		RF	Fire resistant rubber
CVBS	Series Code	CVBS	Bayonet Connector with protected mating ramps
	Shell Material	-	Aluminum
06	Shell Type	06	Plug Connector
ACB	Connector Class	ACB	with waterproof O-ring
T	Connector Modification**	T	With plastic caps
20-27	Insert Arrangement		Size - Type

S	Contact Gender	S	Socket contacts
		P	Pin contacts
X	Polarization Code**		Alternate Positions
CR	Contact Termination	-	Solder contacts
		CR	Crimp contacts
		LC	Less contacts
CD5	Contact Plating	-	Silver plating
		CD5	Gold plating
		F5	Electroless nickel (*)
F7	Shell finish	F7	Black epoxy varnish (*)
		F16	CCF - Black passivation (*) - conductive
		F26	hard anodization (*)
N	Modification Code**	N	Consult our sales office
		S	

P/N Sample: RF CVBS 06ACBT 20-27SX CR CD5 F7 N

(*) RoHS compliance

(**) If required

CVBS - Bayonet Connector with protected mating ramps

Plug Connector (06) with Backshell Class (LAC - LACF)

Connector provided with long backshell, MS3057...C type Cable-Clamp (for jacketed cable)

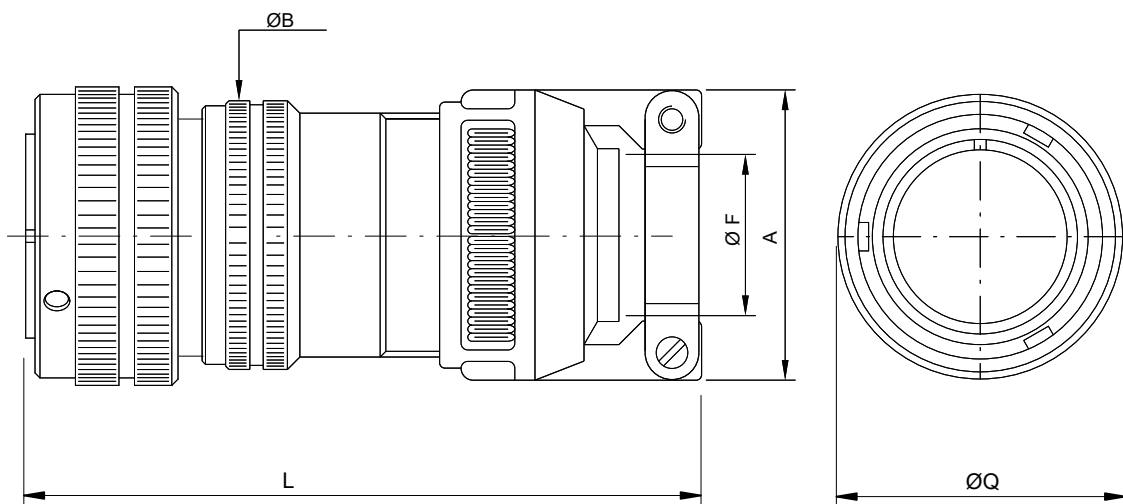

Shell size	ØQ ±0.2	L max	ØB ±0.2	A max	ØF cable dimension	
					Min	Max
10SL	23.3	92	20	23	2.4	7.9
14S	29.5	92	24	26	5.8	11.2
16S	33	93	27	28.5	8	13.5
16	33	103.5	27	28.5	8	13.5
18	37	106	30	32	9.6	15.9
20	41	106	32	37.5	11.3	19
22	43	107	37	37.5	11.3	19
24	48	114.5	40	43.5	15.5	23.8
28	53	114.5	45	43.5	15.5	23.8
32	60	133.5	52	54	23.4	31.8
36	66.2	138	58	58	25.4	35
40	72.4	140.5	63.8	63.5	30	41.3

Dimensions in mm

Dimension "L" can be different from the value indicated according to backshells accessories, wires size and some special insert configurations.

CVBS - Bayonet Connector with protected mating ramps



Series Code: CVBS
 Shell Material: 06
 Shell Type: LACF
 Connector Class: T

Shell finish: F7

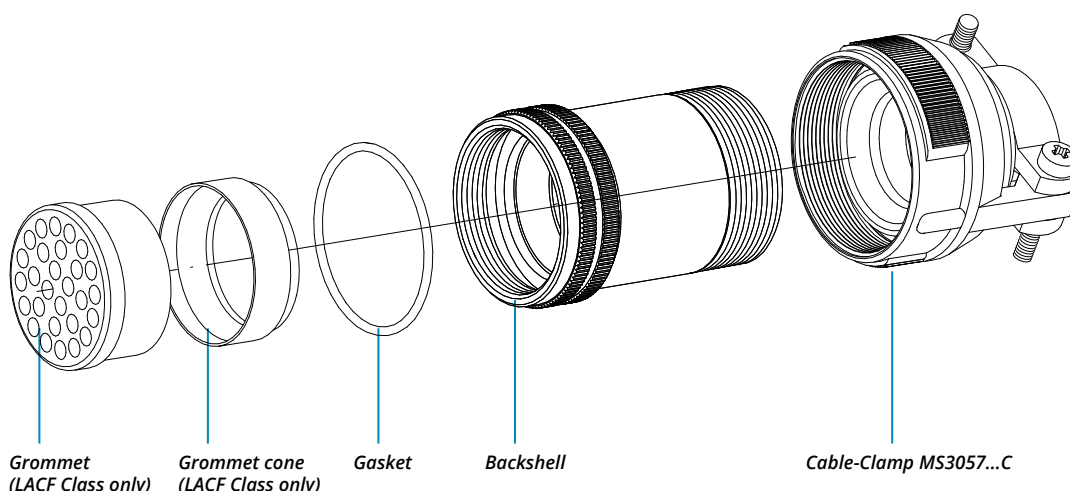

RF	Insulating material	-	Chloroprene rubber
		V	Fluoride rubber
		S	Silicone rubber
		RF	Fire resistant rubber
CVBS	Series Code	CVBS	Bayonet Connector with protected mating ramps
	Shell Material	-	Aluminum
06	Shell Type	06	Plug Connector
LACF	Connector Class	LAC	with waterproof O-ring (IP67)
		LACF	with waterproof O-ring and grommet (IP67)
T	Connector Modification**	T	With plastic caps
20-27	Insert Arrangement		Size - Type

S	Contact Gender	S	Socket contacts
		P	Pin contacts
X	Polarization Code**		Alternate Positions
CR	Contact Termination	-	Solder contacts
		CR	Crimp contacts
		LC	Less contacts
CD5	Contact Plating	-	Silver plating
		CD5	Gold plating
		F5	Electroless nickel (*)
		F7	Black epoxy varnish (*)
F7	Shell finish	F16	CCF - Black passivation (*) - conductive
		F26	hard anodization (*)
		N	Consult our sales office
N	Modification Code**	S	

P/N Sample: RF CVBS 06LACFT 20-27SX CR CD5 F7 N

(*) RoHS compliance

(**) If required

CVBS - Bayonet Connector with protected mating ramps

Plug Connector (06) with Backshell Class (AB)

Connector provided with backshell, MS3057...B type Cable-Clamp (for jacketed cable)

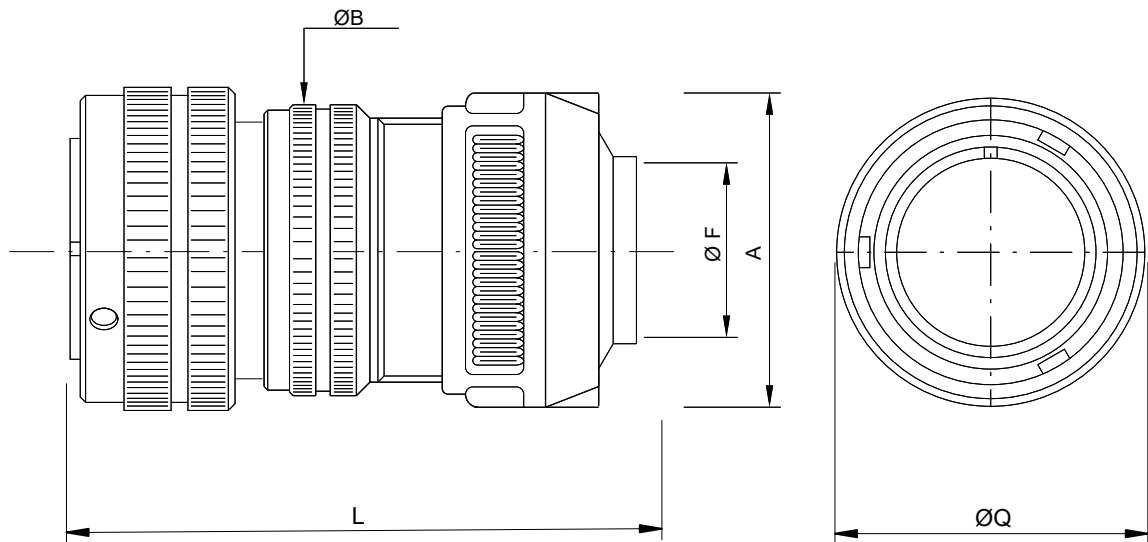

Shell size	ØQ ±0.2	L	ØB ±0.2	A max	ØF cable dimension	
					Min	Max
10SL	23.3	48.4	20	23	2.4	7.9
14S	29.5	56.1	24	26	5.8	11.2
16S	33	57.3	27	28.5	8	13.5
16	33	63.3	27	28.5	8	13.5
18	37	68	30	32	9.6	15.9
20	41	69.2	32	37.5	11.3	19
22	43	71.2	37	37.5	11.3	19
24	48	76.3	40	43.5	15.5	23.8
28	53	83.3	45	43.5	15.5	23.8
32	60	85.1	52	54	23.4	31.8
36	66.2	88.2	58	58	25.4	35
40	72.4	91.5	63.8	63.5	30	41.3

Dimensions in mm

Dimension "L" can be different from the value indicated according to backshells accessories, wires size and some special insert configurations.

CVBS - Bayonet Connector with protected mating ramps

RF	CVBS		06	AB	T	20-27	S	X		CR	CD5	F7		N
Series Code	Shell Material	Shell Type	Connector Class									Shell finish		

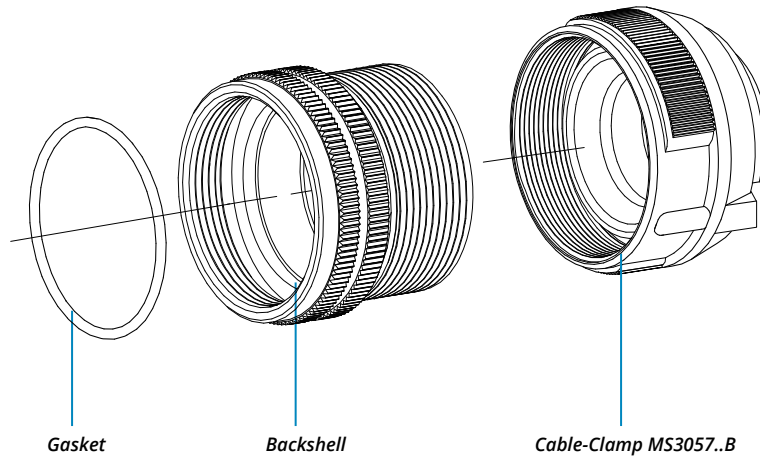

RF	Insulating material	-	Chloroprene rubber
		V	Fluoride rubber
		S	Silicone rubber
		RF	Fire resistant rubber
CVBS	Series Code	CVBS	Bayonet Connector with protected mating ramps
	Shell Material	-	Aluminum
06	Shell Type	06	Plug Connector
AB	Connector Class	AB	with waterproof O-ring
T	Connector Modification**	T	With plastic caps
20-27	Insert Arrangement		Size - Type

S	Contact Gender	S	Socket contacts
		P	Pin contacts
X	Polarization Code**		Alternate Positions
CR	Contact Termination	-	Solder contacts
		CR	Crimp contacts
		LC	Less contacts
CD5	Contact Plating	-	Silver plating
		CD5	Gold plating
		F5	Electroless nickel (*)
F7	Shell finish	F7	Black epoxy varnish (*)
		F16	CCF - Black passivation (*) - conductive
		F26	hard anodization (*)
N	Modification Code**	N	Consult our sales office
		S	

P/N Sample: RF CVBS 06ABT 20-27SX CR CD5 F7 N

(*) RoHS compliance

(**) If required

CVBS - Bayonet Connector with protected mating ramps

Plug Connector (06) with Backshell Class (ASF)

Connector provided with backshell, MS3057...A type Cable-Clamp (for single wire)

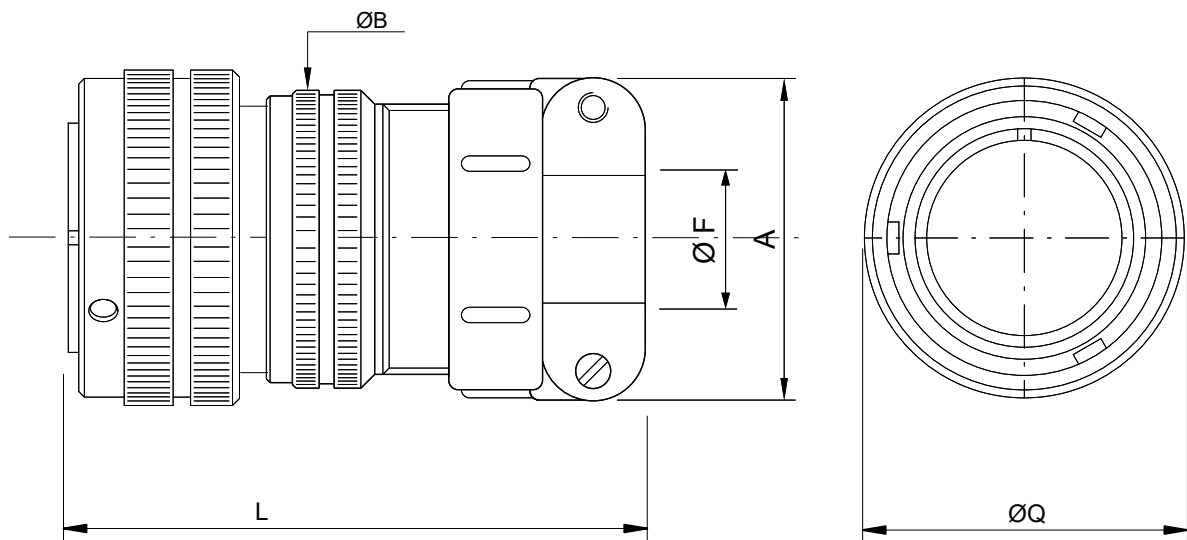

Shell size	ØQ ±0.2	L max	ØB ±0.2	A max	ØF cable max dimension
10SL	23.3	46	20	22.5	8
14S	29.5	55	24	28	11
16S	33	56.5	27	30	14.2
16	33	62.5	27	30	14.2
18	37	67.5	30	31.7	15.8
20	41	68	32	37.5	19
22	43	70.5	37	37.5	19
24	48	70.5	40	43.5	23.8
28	53	77.5	45	43.5	23.8
32	60	77.5	52	51.7	31.7
36	66.2	77.5	58	58.5	35
40	72.4	93	63.8	68.5	41.2

Dimensions in mm

Dimension "L" can be different from the value indicated according to backshells accessories, wires size and some special insert configurations.

CVBS - Bayonet Connector with protected mating ramps

RF	CVBS		06	ASF	T	20-27	S	X		CR	CD5	F7		N
Series Code	Shell Material	Shell Type	Connector Class									Shell finish		

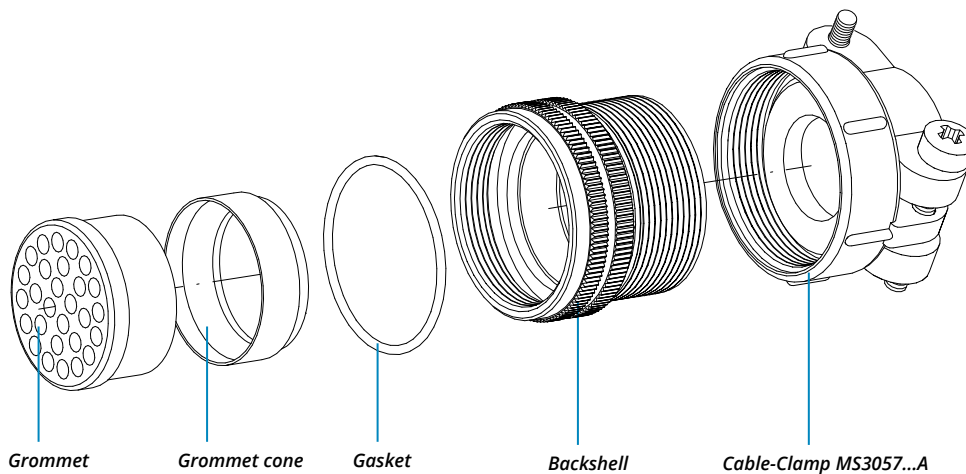

RF	Insulating material	-	Chloroprene rubber
		V	Fluoride rubber
		S	Silicone rubber
		RF	Fire resistant rubber
CVBS	Series Code	CVBS	Bayonet Connector with protected mating ramps
	Shell Material	-	Aluminum
06	Shell Type	06	Plug Connector
ASF	Connector Class	ASF	with waterproof O-ring and grommet
T	Connector Modification**	T	With plastic caps
20-27	Insert Arrangement		Size - Type

S	Contact Gender	S	Socket contacts
		P	Pin contacts
X	Polarization Code**		Alternate Positions
CR	Contact Termination	-	Solder contacts
		CR	Crimp contacts
		LC	Less contacts
CD5	Contact Plating	-	Silver plating
		CD5	Gold plating
		F5	Electroless nickel (*)
		F7	Black epoxy varnish (*)
F7	Shell finish	F16	CCF - Black passivation (*) - conductive
		F26	hard anodization (*)
		N	Consult our sales office
N	Modification Code**	N	
		S	Consult our sales office

P/N Sample: RF CVBS 06ASF T 20-27SX CR CD5 F7 N

(*) RoHS compliance

(**) If required

CVBS - Bayonet Connector with protected mating ramps

Plug Connector (06) with Backshell Class (DA..M - RA..M DA..PG - RA..PG)

Connector with backshell provided with an internal Metric or PG thread suitable for Cable Glands or conduit adapters.

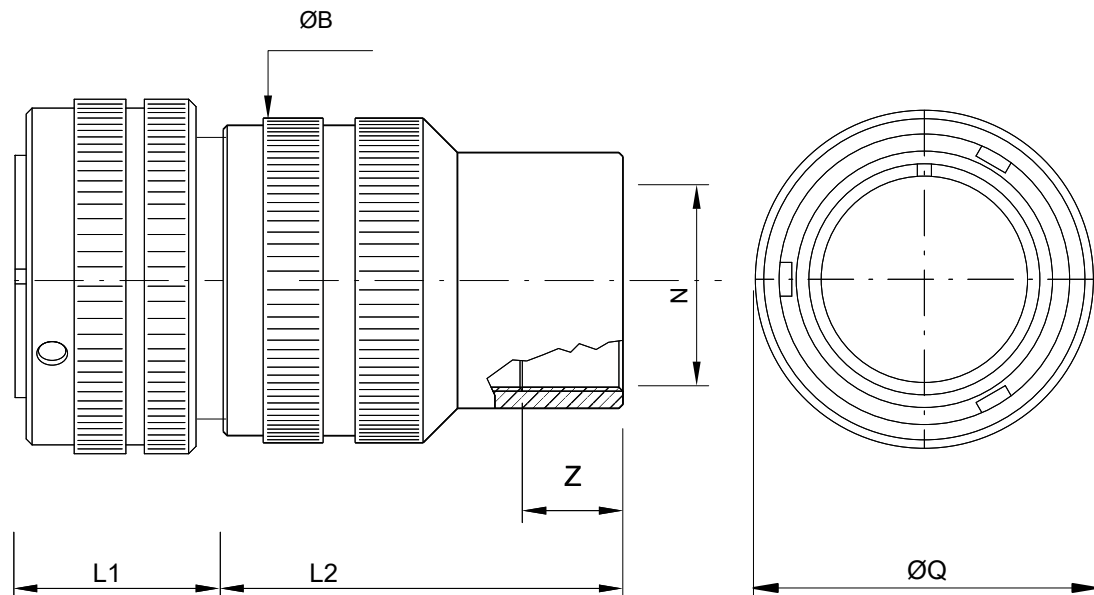

Shell size	ØQ ±0.2	ØB ±0.2	Z min	L1	N Backshell Metric thread	L2 M	N Backshell PG Thread	L2 PG
10SL	23.3	20	8	18,8	M12 - M16	32	(PG9) - PG13.5	26
14S	29.5	24	9	19,6	M12 - M16 - (M20) - (M25)	30	(PG9) - PG11 - PG13.5 - (PG16)	30
16S	33	27	9	19,6	(M16) - M20	40	PG13.5 - (PG16)	38
16	33	27	9	25,6	M20	45	-	40
18	37	30	9	24,9	M20 - M25	50	(PG11) - (PG13.5) - PG16 - PG21	50
20	41	32	9	25,3	M16 - M20 - M25 - (M32)	50	PG11-PG13.5-PG16-PG21-PG29	50
22	43	37	10	25,7	M16 - M20 - M25 - M32	50	PG13.5 - (PG16) - (PG29)	50
24	48	40	10	25,4	M20 - M25 - M32 - M40	50	PG16 - PG21 - PG29	50
28	53	45	10	25,8	(M25) - M32 - M40	63	PG21 - PG29 - PG36	60
32	60	52	10	28,3	(M25) - (M32) - M40	55	PG21 - (PG29) - PG36	60
36	66.2	58	13	28,1	M40 - M50	56	PG29 - (PG36) - (PG42)	65
40	72.4	63.8	13	28,6	M40 - (M50) - M63	65	PG29 - (PG36) - (PG42) - (PG48)	65

Dimensions in mm

Dimensions "L1 and L2" can be different from the value indicated according to backshells accessories, wires size and some special insert configurations.

(...) The threads in parentheses are versions on request with non standard backshell length (the dimensions L2 and Z are different from this page indication).

Please consult our sales office for the specific dimensions.

CVBS - Bayonet Connector with protected mating ramps



Series Code: RF
Shell Material: CVBS
Shell Type: 06
Connector Class: DA

Backshell internal thread: M12
Contact Termination: CR

Shell finish: F7
Modification Code: N

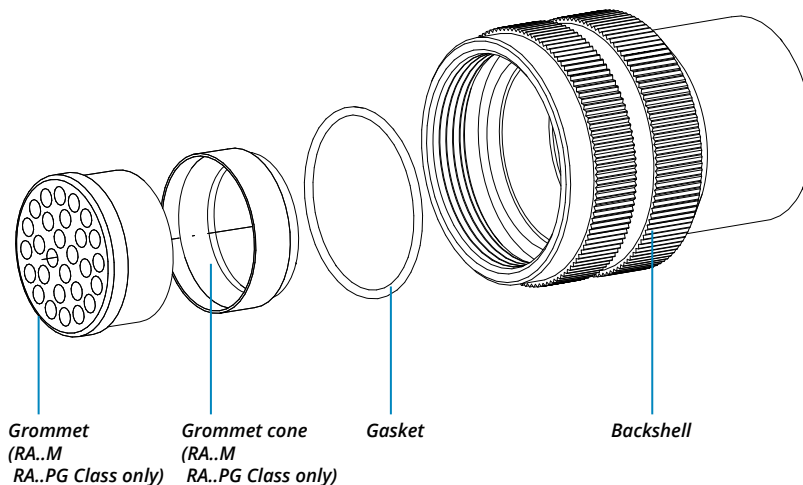

RF	Insulating material	-	Chloroprene rubber
		V	Fluoride rubber
		S	Silicone rubber
		RF	Fire resistant rubber
CVBS	Series Code	CVBS	Bayonet Connector with protected mating ramps
[]	Shell Material	-	Aluminum
06	Shell Type	06	Plug Connector
DA	Connector Class	DA	with waterproof O-ring (IP67***)
		RA	with waterproof O-ring and grommet (IP67***)
T	Connector Modification**	T	With plastic caps
20-27	Insert Arrangement		Size - Type
S	Contact Gender	S	Socket contacts
		P	Pin contacts

X	Polarization Code**		Alternate Positions
M12	Backshell internal thread	M	Provided with an internal Metric thread
		PG	Provided with an internal PG thread
CR	Contact Termination	-	Solder contacts
		CR	Crimp contacts
		LC	Less contacts
CD5	Contact Plating	-	Silver plating
		CD5	Gold plating
		F5	Electroless nickel (*)
		F7	Black epoxy varnish (*)
F7	Shell finish	F16	CCF - Black passivation (*) - conductive
		F26	hard anodization (*)
		N	Consult our sales office
N	Modification Code**	S	

*** Protection degree: IP 67 (only in the mating area with mated connectors) according to EN 60529 (*) RoHS compliance (***) If required

P/N Sample: RF CVBS 06DAT 20-27SX M12 CR CD5 F7 N

CVBS - Bayonet Connector with protected mating ramps

Plug Connector (06) with Backshell Class (DA..MH - RA..MH DA..PH - RA..PH)

Connector with backshell provided with a Metric or PG thread metal Cable Glands.

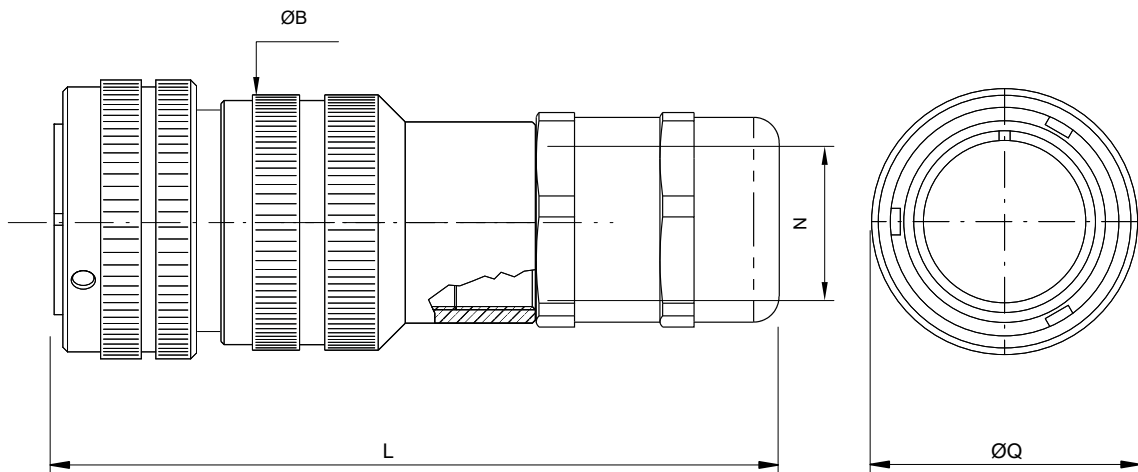

Shell size	ØQ ±0.2	L max	ØB ±0.2	Backshell Metric Thread	ØN Clamping range
10SL	23.3	88	20	M12	3.5-7
14S	29.5	94	24	M16	4.5-10
16S	33	97.5	27	M20	7-13
16	33	105.5	27	M20	7-13
18	37	105.5	30	M20	7-13
20	41	106.5	32	M25	9-17
22	43	112.5	37	M32	11-21
24	48	112.5	40	M32	11-21
28	53	122.5	45	M32	11-21
32	60	126	52	M40	19-28
36	66.2	131	58	M40	19-28
40	72.4	139	63.8	M40	19-28

Dimensions in mm

Dimension "L" can be different from the value indicated according to backshells accessories, wires size and some special insert configurations.

CVBS - Bayonet Connector with protected mating ramps



Series Code: CVBS
Shell Material: 06
Shell Type: DA
Connector Class: T

Backshell internal thread: MH12
Contact Termination: CR
Contact Plating: CD5

Shell finish: F7
Modification Code: N

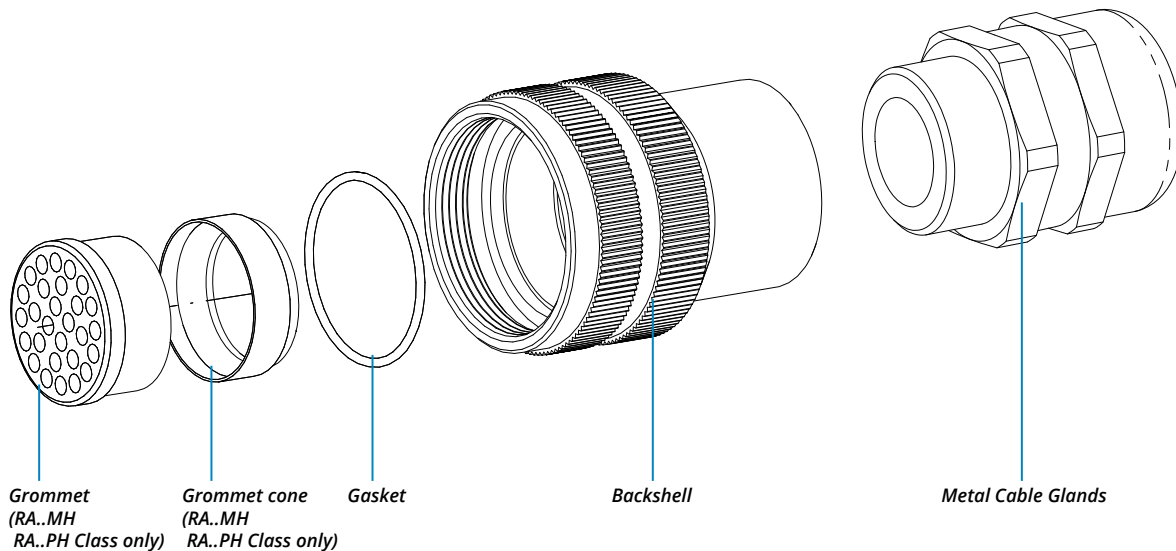

RF	Insulating material	-	Chloroprene rubber
		V	Fluoride rubber
		S	Silicone rubber
		RF	Fire resistant rubber
CVBS	Series Code	CVBS	Bayonet Connector with protected mating ramps
	Shell Material	-	Aluminum
06	Shell Type	06	Plug Connector
DA	Connector Class	DA	with waterproof O-ring (IP67)
		RA	with waterproof O-ring and grommet (IP67)
T	Connector Modification**	T	With plastic caps
20-27	Insert Arrangement		Size - Type
S	Contact Gender	S	Socket contacts
		P	Pin contacts

X	Polarization Code**		Alternate Positions
MH12	Backshell internal thread	MH	Provided with a Metric thread Cable Glands
		PH	Provided with a PG thread Cable Glands**
CR	Contact Termination	-	Solder contacts
		CR	Crimp contacts
		LC	Less contacts
CD5	Contact Plating	-	Silver plating
		CD5	Gold plating
F7	Shell finish	F5	Electroless nickel (*)
		F7	Black epoxy varnish (*)
		F16	CCF - Black passivation (*) - conductive
		F26	hard anodization (*)
N	Modification Code**	N	Consult our sales office
		S	Consult our sales office

P/N Sample: RF CVBS 06DAT 20-27SX MH12 CR CD5 F7 N (*) RoHS compliance (**) If required *** Consult our sales office

CVBS - Bayonet Connector with protected mating ramps

Plug Connector (06) with Backshell Class (AR - R)

This class is suitable to connect single wires when strain relief is not necessary and small longitudinal overall dimensions are needed. As watertightness is guaranteed by the grommet only, it is necessary to make sure the wire diameter matches the grommet sealing range.

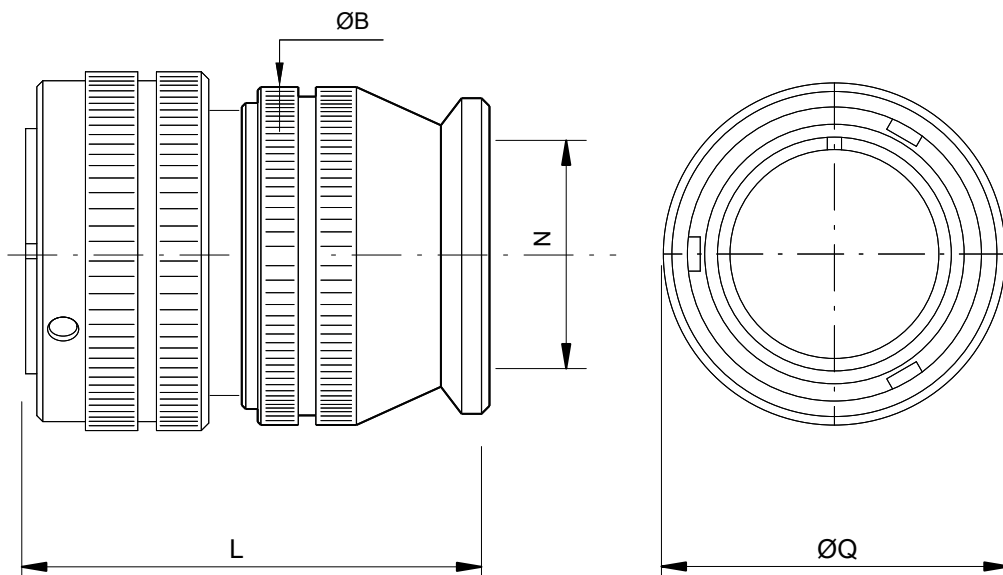

Shell size	ØQ ±0.2	ØB ±0.2	L max	N max cable dimension
10SL	23.3	20	36	10
14S	29.5	24	42	13.5
16S	33	27	42	16.1
16	33	27	48	16.5
18	37	30	51	19
20	41	32	51	22.2
22	43	37	54	24.5
24	48	40	54	28
28	53	45	61	32.6
32	60	52	61	38
36	66.2	58	61	45
40	72.4	63.8	63	51.3

Dimensions in mm

Dimension "L" can be different from the value indicated according to backshells accessories, wires size and some special insert configurations.

CVBS - Bayonet Connector with protected mating ramps

RF	CVBS		06	R	T	20-27	S	X		CR	CD5	F7		N
Series Code	Shell Material	Shell Type	Connector Class									Shell finish		

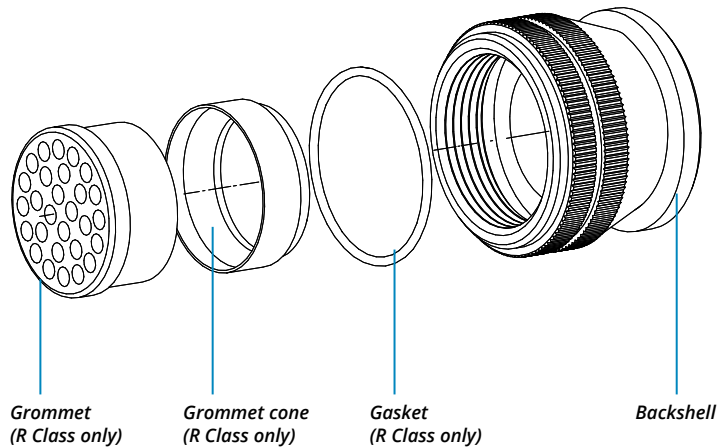

The accessories for this class are not always available in stock for all sizes; we suggest you consult our Sales Office for availability

RF	Insulating material	-	Chloroprene rubber	S	Contact Gender	S	Socket contacts
		V	Fluoride rubber			P	Pin contacts
		S	Silicone rubber				
		RF	Fire resistant rubber				
CVBS	Series Code	CVBS	Bayonet Connector with protected mating ramps	X	Polarization Code**		Alternate Positions
	Shell Material	-	Aluminum	CR	Contact Termination	-	Solder contacts
						CR	Crimp contacts
						LC	Less contacts
06	Shell Type	06	Plug Connector	CD5	Contact Plating	-	Silver plating
						CD5	Gold plating
R	Connector Class	AR	non watertight	F7	Shell finish	F5	Electroless nickel (*)
		R	with waterproof O-ring and grommet			F7	Black epoxy varnish (*)
						F16	CCF - Black passivation (*) - conductive
						F26	hard anodization (*)
T	Connector Modification**	T	With plastic caps	N	Modification Code**	N	Consult our sales office
						S	
20-27	Insert Arrangement		Size - Type				

P/N Sample: RF CVBS 06RT 20-27SX CR CD5 F7 N

(*) RoHS compliance

(**) If required

CVBS - Bayonet Connector with protected mating ramps

Plug Connector (06) with Backshell Class (AG - G)

These classes of connectors are all suitable for heat shrink tubing applications.

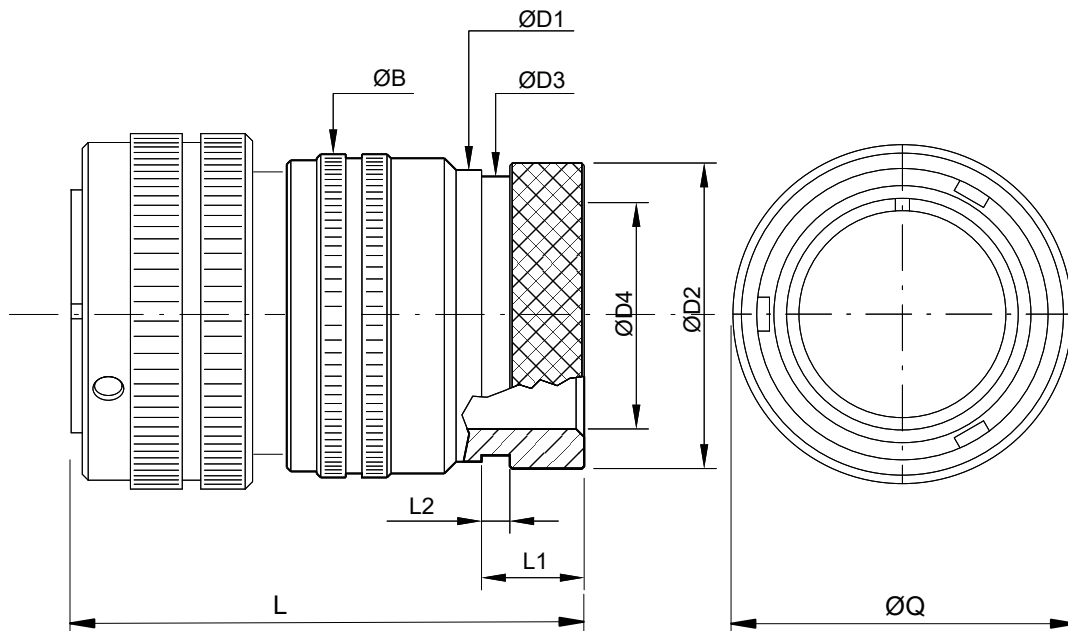

Shell size	ØQ ±0.2	ØB ±0.2	ØD1 ±0.2	ØD2 ±0.2	ØD3 ±0.2	ØD4 ±0.2	L	L1 ±0.2	L2 ±0.2
10SL	23.3	20	17	15.5	13.3	7.9	49	11.7	3.5
14S	29.5	24	20.1	19.1	17	13.5	49	11.7	3.5
16S	33	27	23.5	23.9	21.9	13.7	49	11.7	3.5
16	33	27	23.5	23.9	21.9	16.1	60	11.5	3.5
18	37	30	26.5	23.9	21.9	19	64	11.5	3.5
20	41	32	30.2	29.6	26.2	22.2	64	12.4	3.5
22	43	37	33.6	29.6	26.2	22	64	12.7	3.5
24	48	40	36.1	37.8	34.5	28	64	12.7	3.5
28	53	45	41.4	37.8	34.5	29	64	12.7	3.5
32	60	52	50	47.8	43.4	35.2	70	15.2	3.5
36	66.2	58	56	47.7	43.4	40	75	15.2	3.5
40	72.4	63.8	62.4	57.6	52.4	48	78	15.2	3.5

Dimensions in mm

Dimension "L" can be different from the value indicated according to backshells accessories, wires size and some special insert configurations.

CVBS - Bayonet Connector with protected mating ramps

RF	CVBS		06	AG	T	20-27	S	X		CR	CD5	F7		N
Series Code	Shell Material	Shell Type	Connector Class									Shell finish		

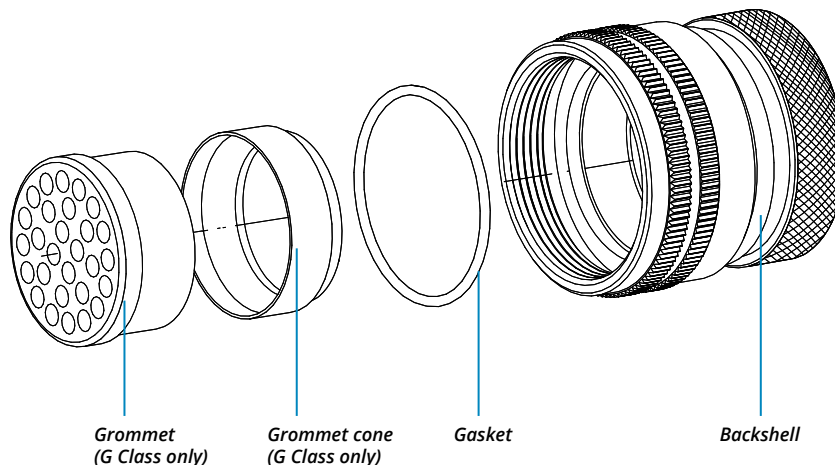

The accessories for this class are not always available in stock for all sizes; we suggest you consult our Sales Office for availability

RF	Insulating material	-	Chloroprene rubber	S	Contact Gender	S	Socket contacts
		V	Fluoride rubber			P	Pin contacts
		S	Silicone rubber				
		RF	Fire resistant rubber				
CVBS	Series Code	CVBS	Bayonet Connector with protected mating ramps	X	Polarization Code**		Alternate Positions
	Shell Material	-	Aluminum	CR	Contact Termination	-	Solder contacts
						CR	Crimp contacts
						LC	Less contacts
06	Shell Type	06	Plug Connector	CD5	Contact Plating	-	Silver plating
						CD5	Gold plating
AG	Connector Class	AG	with waterproof O-ring (IP67***)	F7	Shell finish	F5	Electroless nickel (*)
		G	with waterproof O-ring and grommet (IP67***)			F7	Black epoxy varnish (*)
						F16	CCF - Black passivation (*) - conductive
						F26	hard anodization (*)
T	Connector Modification**	T	With plastic caps	N	Modification Code**	N	Consult our sales office
						S	
20-27	Insert Arrangement		Size - Type				

*** Protection degree: IP 67 (only in the mating area with mated connectors) according to EN 60529 (*) RoHS compliance (***) If required

P/N Sample: RF CVBS 06AGT 20-27SX CR CD5 F7 N

CVBS - Bayonet Connector with protected mating ramps

Plug Connector (06) with Backshell Class (DA..FS - RA..FS)

Connector with special adapter for rubber conduits.

Conduit's size must be specified adding the diameter dimensions in the P/N (i.e.: CVBS 06DA...FS5040...).

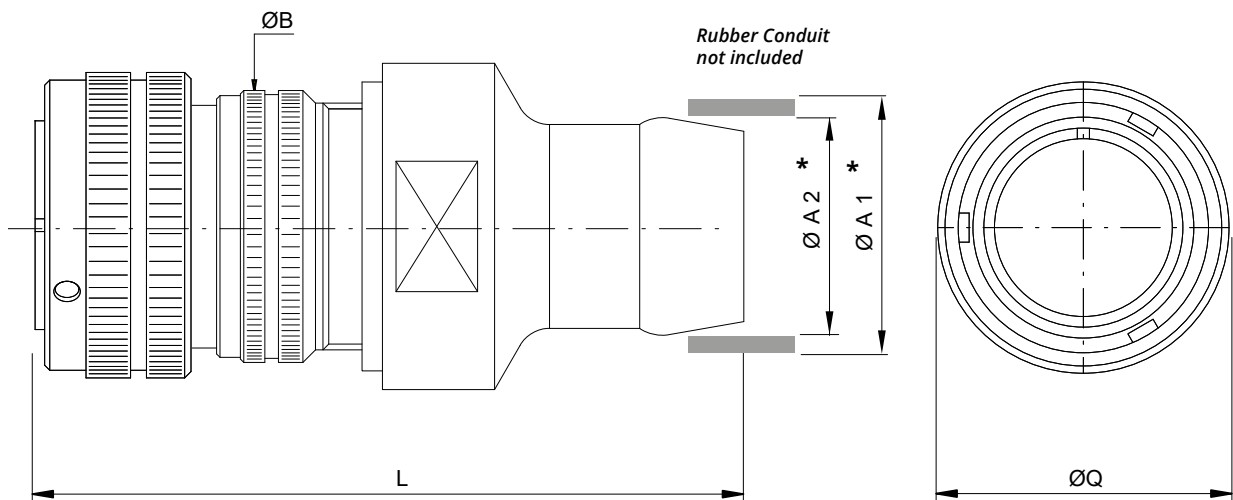

Please consult our Sales Office for further details about this dimension and according to conduit size.

Shell size	ØQ ±0.2	L max	ØB max	Backshell Conduit Size	ØA1*	ØA2*	Backshell Conduit Size	ØA1*	ØA2*
18	37	103	30	FS1712	17	12	FS3530	35	30
20	41	103	32	FS1813	18	13	FS4030	40	30
22	43	103	37	FS2015	20	15	FS4035	40	35
24	48	105	40	FS2318	23	18	FS4236	42	36
28	53	111	45	FS2520	25	20	FS4540	45	40
32	60	117	52	FS2618	26	18	FS4843	48	43
36	66.2	122	58	FS2620	26	20	FS5040	50	40
40	72.4	122	63.8	FS2722	27	22	FS5045	50	45
				FS2820	28	20	FS5550	55	50
				FS3328	33	28	FS5945	59	45

Dimensions in mm

Dimension "L" can be different from the value indicated according to backshells accessories, wires size and some special insert configurations.

CVBS - Bayonet Connector with protected mating ramps

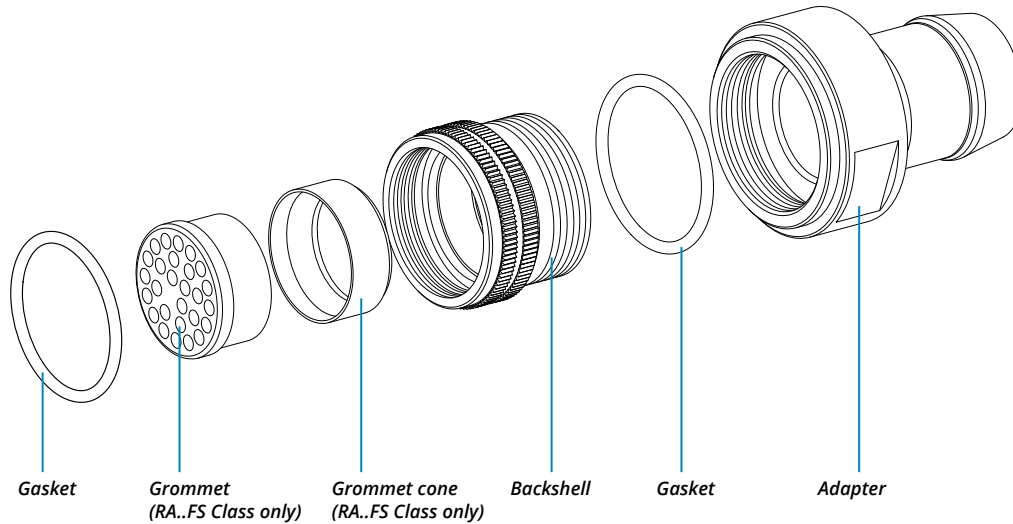

The accessories for this class are not always available in stock for all sizes; we suggest you consult our Sales Office for availability

RF Insulating material	-	Chloroprene rubber	X Polarization Code**		Alternate Positions
	V	Fluoride rubber			
	S	Silicone rubber	FS.. Backshell Conduits size or internal thread	FS	Provided with a special adapter for rubber conduits
	RF	Fire resistant rubber	xxxx Conduit Size	xxxx	ØA1ØA2
CVBS Series Code	CVBS	Bayonet Connector with protected mating ramps	CR Contact Termination	-	Solder contacts
[] Shell Material	-	Aluminum		CR	Crimp contacts
06 Shell Type	06	Plug Connector		LC	Less contacts
DA Connector Class	DA	with waterproof O-ring (IP67***)	CD5 Contact Plating	-	Silver plating
	RA	with waterproof O-ring and grommet (IP67***) #		CD5	Gold plating
T Connector Modification**	T	With plastic caps	F7 Shell finish	F5	Electroless nickel (*)
20-27 Insert Arrangement		Size - Type		F7	Black epoxy varnish (*)
S Contact Gender	S	Socket contacts		F16	CCF - Black passivation (*) - conductive
	P	Pin contacts	N Modification Code**	F26	hard anodization (*)
				N	Consult our sales office
				S	

*** Protection degree: IP 67 (only in the mating area with mated connectors) according to EN 60529 (*) RoHS compliance (***) If required

P/N Sample: RF CVBS 06DAT 20-27SX FS5040 CR CD5 F7 N (#) In some sizes the grommet cone is not needed

CVBS - Bayonet Connector with protected mating ramps

Plug Connector (06) with Backshell Class (DA..MTG - RA..MTG)

Connector with a special adapter for clamping and retaining rubber conduits, with nut.
Conduit's size must be specified adding the diameter dimensions in the P/N (i.e.: CVBS 06DA...MTG2025...).

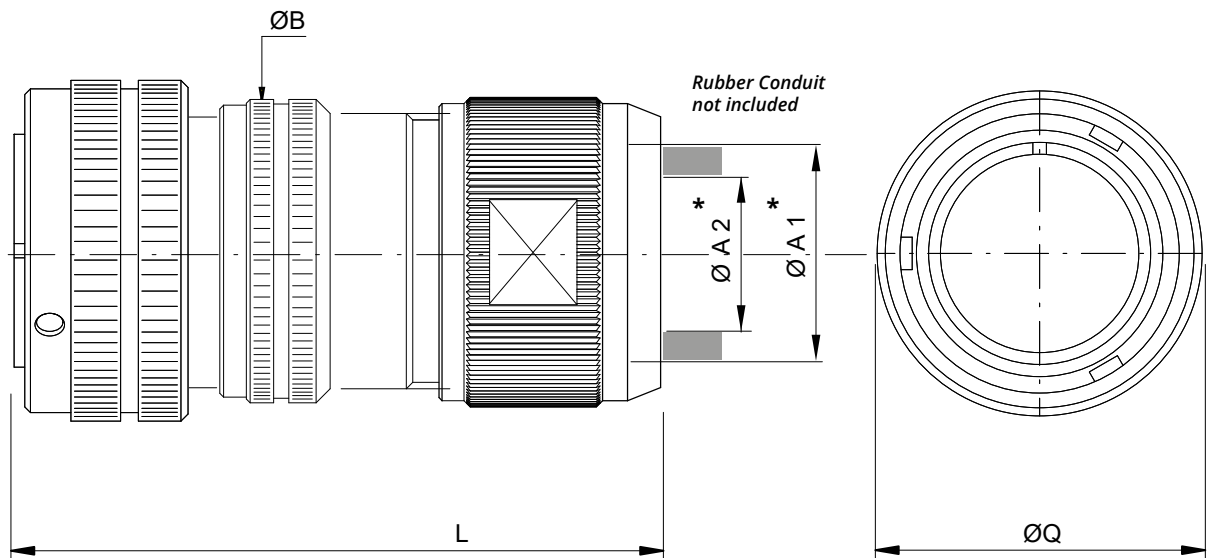

Shell size	ØQ ±0.2	L max	ØB max	Backshell Conduit Size	ØA1*	ØA2*	Shell size
18	37	101	30	MTG1712	17	12	18
20	41	101	32	MTG2015	20	15	18-24
22	43	101	37	MTG2318	23	18	24-32
24	48	107	40	MTG2520	25	20	28
28	53	110	45	MTG2924	29	24	28
32	60	114	52	MTG3328	33	28	36-32
36	66.2	120	58	MTG3530	35	30	36
40	72.4	121	63.8	MTG3628	36	28	36
				MTG3833	38	33	40
				MTG4035	40	35	40
				MTG4237	42	37	40
				MTG4238	42	38	40
				MTG4840	48	40	40

Dimensions in mm

Dimension "L" can be different from the value indicated according to backshells accessories, wires size and some special insert configurations.

* Dimensions ØA1 and ØA2 are determined by conduit size.

CVBS - Bayonet Connector with protected mating ramps



Series Shell Code Material Type Connector Class

Backshell Conduits size or internal thread

Shell finish

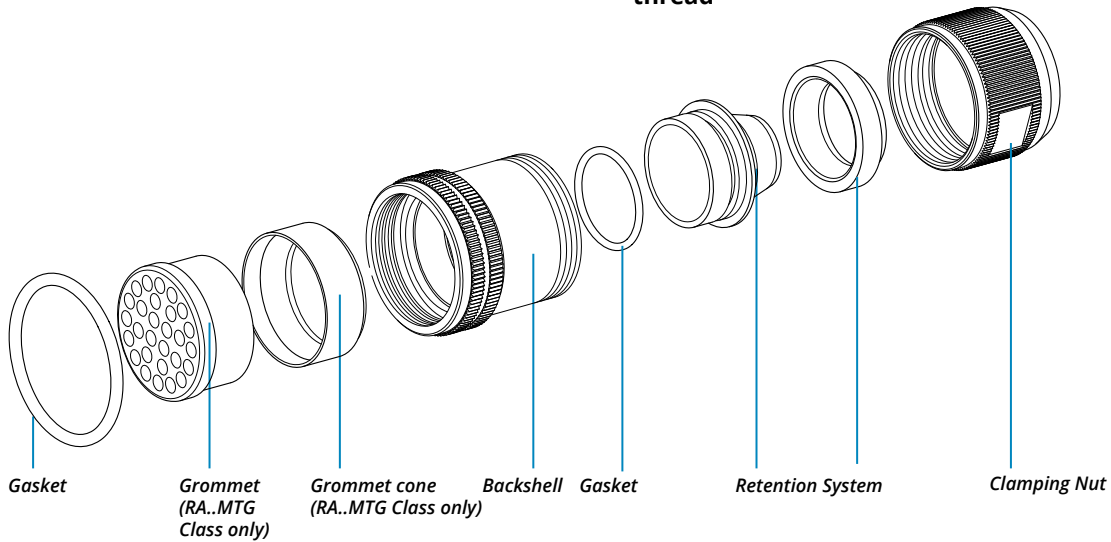

The accessories for this class are not always available in stock for all sizes; we suggest you consult our Sales Office for availability

RF	Insulating material	-	Chloroprene rubber	X	Polarization Code**	Alternate Positions	
		V	Fluoride rubber				
		S	Silicone rubber				
		RF	Fire resistant rubber				
CVBS	Series Code	CVBS	Bayonet Connector with protected mating ramps	MTG	Backshell Conduits size or internal thread	MTG	Provided with a special adapter for rubber conduits, with nut.
[]	Shell Material	-	Aluminum	2520	Conduit Size	xxxx	ØA1ØA2
06	Shell Type	06	Plug Connector	CR	Contact Termination	-	Solder contacts
		CR	Crimp contacts			LC	Less contacts
DA	Connector Class	DA	with waterproof O-ring (IP67***)	CD5	Contact Plating	-	Silver plating
		RA	with waterproof O-ring and grommet (IP67***) #			CD5	Gold plating
		F5	Electroless nickel (*)			F7	Black epoxy varnish (*)
T	Connector Modification**	T	With plastic caps	F7	Shell finish	F16	CCF - Black passivation (*) - conductive
		F26	hard anodization (*)			N	Modification Code**
20-27	Insert Arrangement		Size - Type			S	Consult our sales office
S	Contact Gender	S	Socket contacts				
		P	Pin contacts				

*** Protection degree: IP 67 (only in the mating area with mated connectors) according to EN 60529 (*) RoHS compliance (**) If required

P/N Sample: RF CVBS 06DAT 20-27SX MTG2025 CR CD5 F7 N

(#) In some sizes the grommet cone is not needed

CVBS - Bayonet Connector with protected mating ramps

Plug Connector (06) with Backshell Class (AG2 - G2)

These classes of connectors are all suitable for heat shrink tubing applications. Two piece backshell includes nut for shell tightening. Internal serration prevents backshell rotation and allows easy assembling after contacts are inserted.

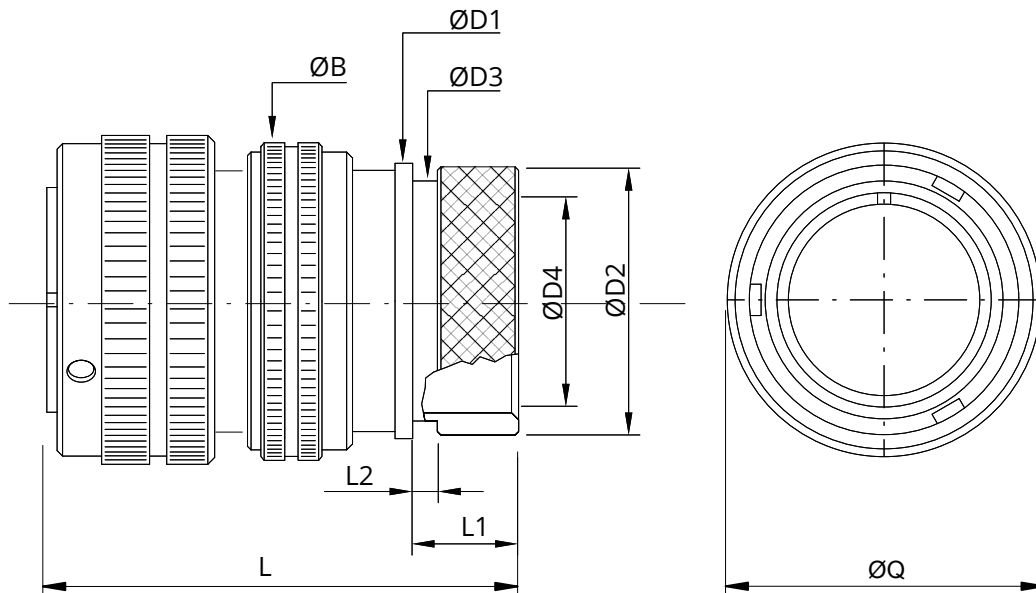

Shell size	ØQ	ØB ±0.2	ØD1 ±0.2	ØD2 ±0.2	ØD3 ±0.2	ØD4 ±0.2	L	L1 ±0.2	L2 ±0.2
10SL	23.3	22.5	17	15.5	13.3	8.6	51	11.7	3.5
14S	29.5	26	20.1	19.1	17	10.8	52	11.7	3.5
16S	33	29	23.5	23.9	21.9	14	53.5	11.7	3.5
16	33	29	23.5	23.9	21.9	14	62	11.5	3.5
18	37	33.4	26.5	23.9	21.9	14.8	61.5	11.5	3.5
20	41	37	30.2	29.6	26.2	19.3	62.5	12.4	3.5
22	43	41	33.6	29.6	26.2	22.5	62.5	12.7	3.5
24	48	45.9	36.1	37.8	34.5	28	63	12.7	3.5
28	53	51	41.4	37.8	34.5	28	65	12.7	3.5
32	60	58	50	47.8	43.4	34.8	67	15.2	3.5
36	66.2	60.5	56	47.7	43.4	38.7	67	15.2	3.5
40	72.4	69	62.4	57.6	52.4	48.2	68.5	15.2	3.5

Dimensions in mm

Dimension "L" can be different from the value indicated according to backshells accessories, wires size and some special insert configurations.

CVBS - Bayonet Connector with protected mating ramps



Series Code: CVBS
 Shell Material Type: 06
 Connector Class: G2

Shell finish: F7

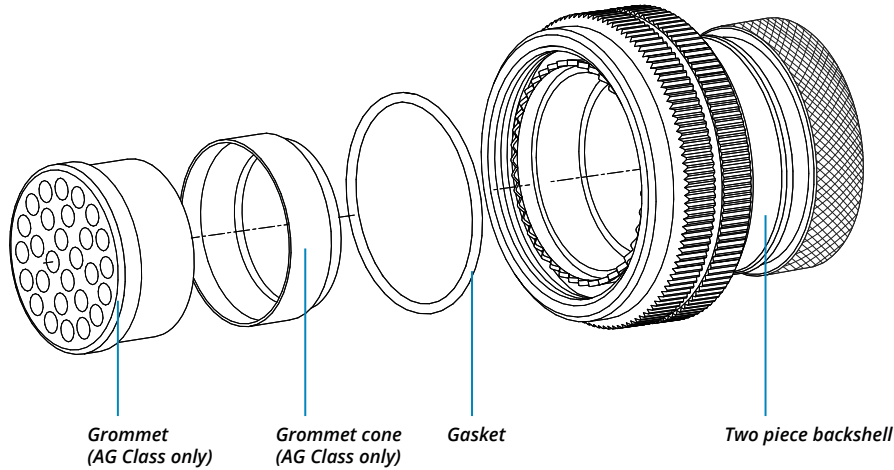

The accessories for this class are not always available in stock for all sizes; we suggest you consult our Sales Office for availability

RF	Insulating material	-	Chloroprene rubber	S	Contact Gender	S	Socket contacts		
		V	Fluoride rubber			P	Pin contacts		
		S	Silicone rubber						
		RF	Fire resistant rubber						
CVBS	Series Code	CVBS	Bayonet Connector with protected mating ramps	X	Polarization Code**		Alternate Positions		
	Shell Material	-	Aluminum	CR	Contact Termination	-	Solder contacts		
						CR	Crimp contacts		
						LC	Less contacts		
06	Shell Type	06	Plug Connector	CD5	Contact Plating	-	Silver plating		
						CD5	Gold plating		
G2	Connector Class	AG2	With waterproof O-ring (IP67***)	F7	Shell finish	F5	Electroless nickel (*)		
		G2	With waterproof O-ring and grommet (IP67***)#			F7	Black epoxy varnish (*)		
								F16	CCF - Black passivation (*) - conductive
								F26	hard anodization (*)
T	Connector Modification**	T	With plastic caps	N	Modification Code**	N	Consult our sales office		
						S	Consult our sales office		
20-27	Insert Arrangement		Size - Type						

*** Protection degree: IP 67 (only in the mating area with mated connectors) according to EN 60529

(*) RoHS compliance (***) If required

P/N Sample: RF CVBS 06G2T 20-27SX CR CD5 F7 N

(#) In some sizes the grommet cone is not needed

CVBS - Bayonet Connector with protected mating ramps

Plug Connector (06) with Backshell Class (AWN - WN)

Connectors is provided with gasket and iris spring connected to one another by an internal ring. When screwing the rear oupling nut, the gasket and the spring tighten around the cable or the hose, so to guarantee an excellent mechanical strain relief and watertightness. Clamping range on the dimension table has to be chosen according to the cable size and its shielding and specified in the connector P/N.

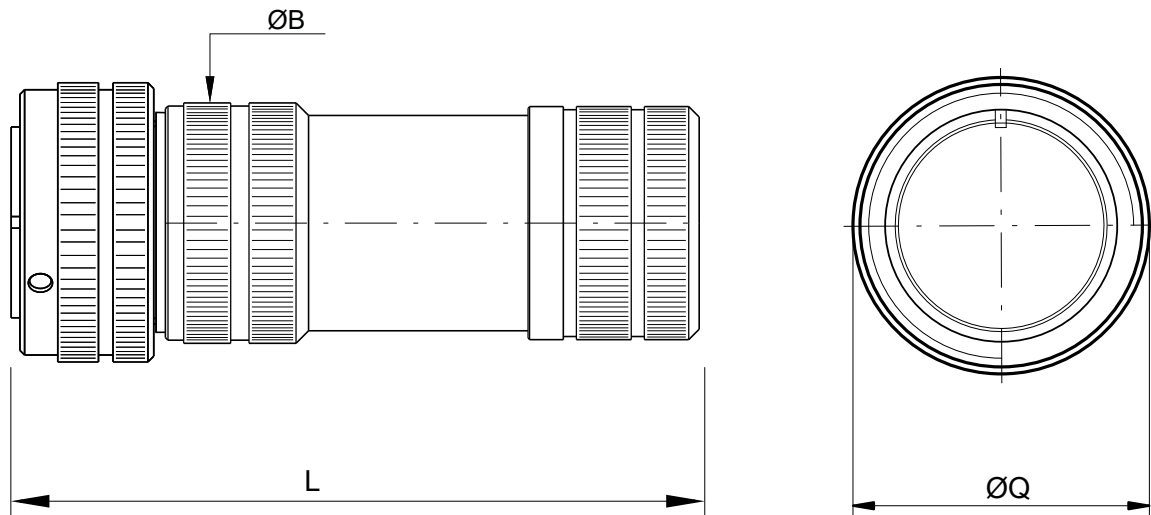

Shell size	ØQ	ØB	L
10SL	23.3	20	***
14S	29.5	24	***
16S	33	27	***
16	33	27	***
18	37	30	***
20	41	32	100
22	43	37	***
24	48	40	***
28	53	45	***
32	60	52	***
36	66.2	58	***
40	72.4	63.8	***

Dimensions in mm

Dimension "L" can be different from the value indicated according to backshells accessories, wires size and some special insert configurations.

*** On request

Size *	Clamping Range **	
	max	min
01	6	3
02	9.5	5
03	13	8.5
04	16.5	12
05	20	15.5
06	23.5	19
07	27	22.5
08	30.5	26
09	34	29.5
10	37.5	33
11	41	36.5
12	44.5	40
13	48	43.5
14	51.5	47

* Must be specified in the connector

** Clamping range to be verified with cable section. Please consult our Sales Office.

CVBS - Bayonet Connector with protected mating ramps



Series Shell Shell Connector Clamping Shell
Code Material Type Class Range Type finish

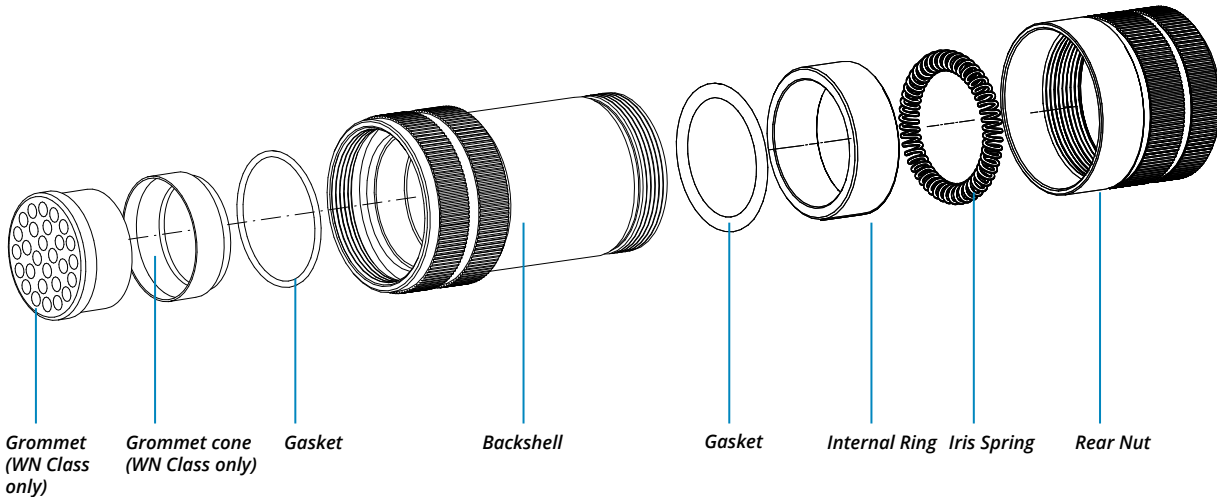

The accessories for this class are not always available in stock for all sizes; we suggest you consult our Sales Office for availability

RF	Insulating material	-	Chloroprene rubber	20-27	Insert Arrangement	Size - Type	
		V	Fluoride rubber		S	S	Socket contacts
		S	Silicone rubber			P	Pin contacts
CVBS	Series Code	CVBS	Bayonet Connector with protected mating ramps		X	Polarization Code**	Alternate Positions
		RF	Fire resistant rubber		CR	Contact Termination	- Solder contacts CR Crimp contacts LC Less contacts
	Shell Material	-	Aluminum		CD5	Contact Plating	- Silver plating CD5 Gold plating
06	Shell Type	06	Plug Connector		F7	Shell finish	F5 Electroless nickel (*) F7 Black epoxy varnish (*) F16 CCF - Black passivation (*) - conductive F26 hard anodization (*)
WN	Connector Class	AWN	with waterproof O-ring (IP67***)		N	Modification Code**	N Consult our sales office S
		WN	With waterproof O-ring and grommet (IP67***)#				
T	Connector Modification**	T	With plastic caps				
01	Clamping Size	xx	Clamping Range				

*** Protection degree: IP 67 (only in the mating area with mated connectors) according to EN 60529

(*) RoHS compliance (***) If required

P/N Sample: RF CVBS 06WNT01 20-27SX CR CD5 F7 N

(#) In some sizes the grommet cone is not needed

CVBS - Bayonet Connector with protected mating ramps

Plug Connector (96) with Backshell Class (AC - ACF)

Connector provided with grounding finger to guarantee shielding; with backshell, MS3057...C type Cable-Clamp (for jacketed cable)



Grounding finger

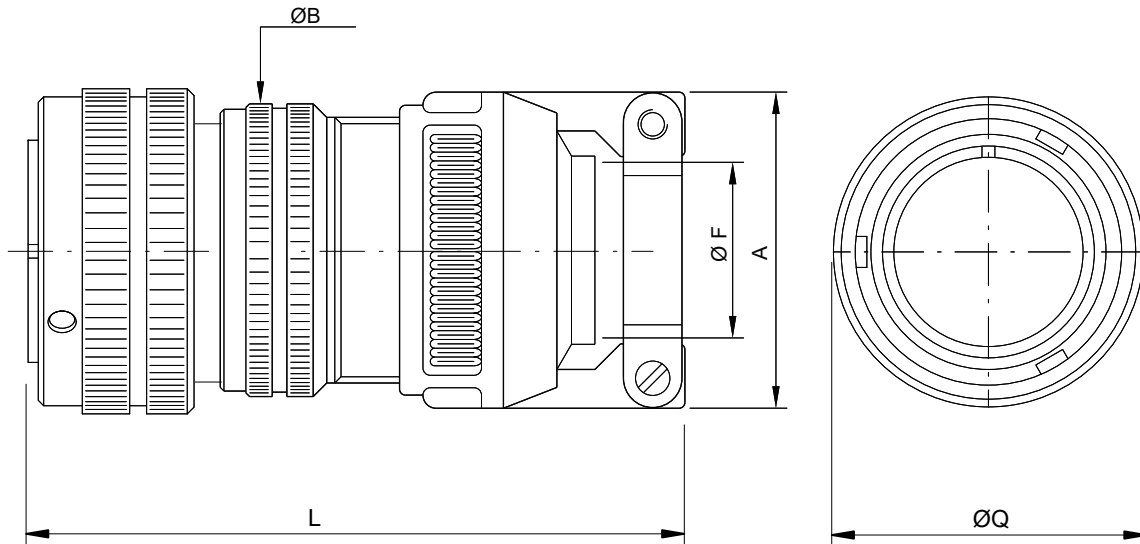
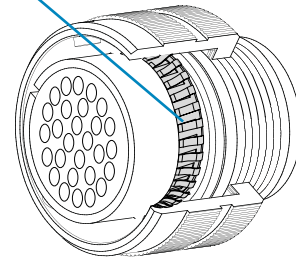

Shell size	ØQ ±0.2	L max	ØB ±0.2	A max	ØF cable dimension	
					Min	Max
10SL	23.3	60	20	23	2.4	7.9
14S	29.5	67	24	26	5.8	11.2
16S	33	68	27	28.5	8	13.5
16	33	74	27	28.5	8	13.5
18	37	79.5	30	32	9.6	15.9
20	41	79.5	32	37.5	11.3	19
22	43	81.5	37	37.5	11.3	19
24	48	88.5	40	43.5	15.5	23.8
28	53	95.5	45	43.5	15.5	23.8
32	60	100	52	54	23.4	31.8
36	66.2	104.5	58	58	25.4	35
40	72.4	108	63.8	63.5	30	41.3

Dimensions in mm

Dimension "L" can be different from the value indicated according to backshells accessories, wires size and some special insert configurations.

CVBS - Bayonet Connector with protected mating ramps



Series Code Shell Material Shell Type Connector Class

Shell finish

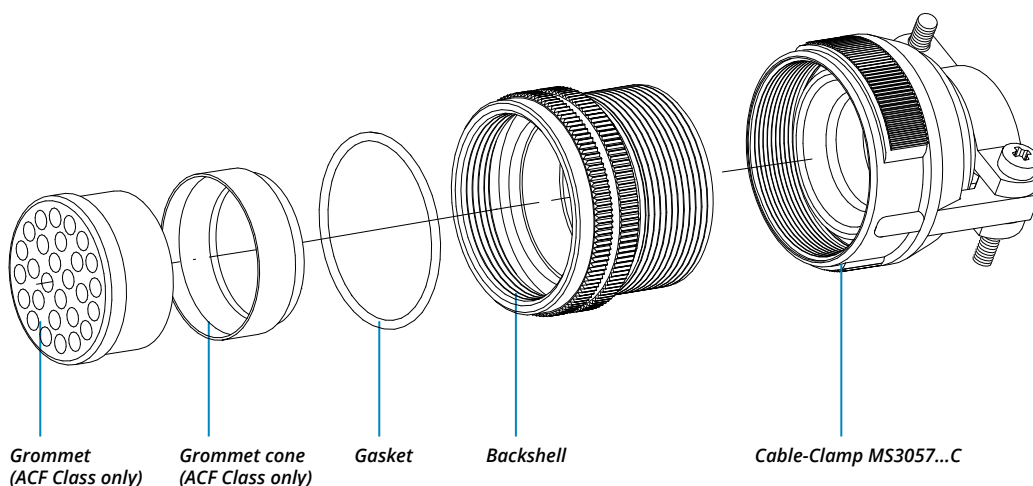

RF	Insulating material	-	Chloroprene rubber
		V	Fluoride rubber
		S	Silicone rubber
		RF	Fire resistant rubber
CVBS	Series Code	CVBS	Bayonet Connector with protected mating ramps
[]	Shell Material	-	Aluminum
96	Shell Type	96	Plug Connector with grounding finger
ACF	Connector Class	AC	with waterproof O-ring (IP67)
		ACF	with waterproof O-ring and grommet (IP67)
T	Connector Modification**	T	With plastic caps

20-27	Insert Arrangement		Size - Type
S	Contact Gender	S	Socket contacts
		P	Pin contacts
X	Polarization Code**		Alternate Positions
CR	Contact Termination	-	Solder contacts
		CR	Crimp contacts
		LC	Less contacts
CD5	Contact Plating	-	Silver plating
		CD5	Gold plating
F16	Shell finish	F16	CCF - Black passivation (*) - conductive
N	Modification Code**	N	Consult our sales office
		S	

P/N Sample: RF CVBS 96ACFT 20-27SX CR CD5 F16 N

(*) RoHS compliance

(**) If required

CVBS - Bayonet Connector with protected mating ramps

Plug Connector (96) with Backshell Class (DA..M - RA..M DA..PG - RA..PG)

Connector provided with grounding finger to guarantee shielding;
with backshell provided with an internal Metric or PG thread suitable for Cable Glands or conduit adapters.

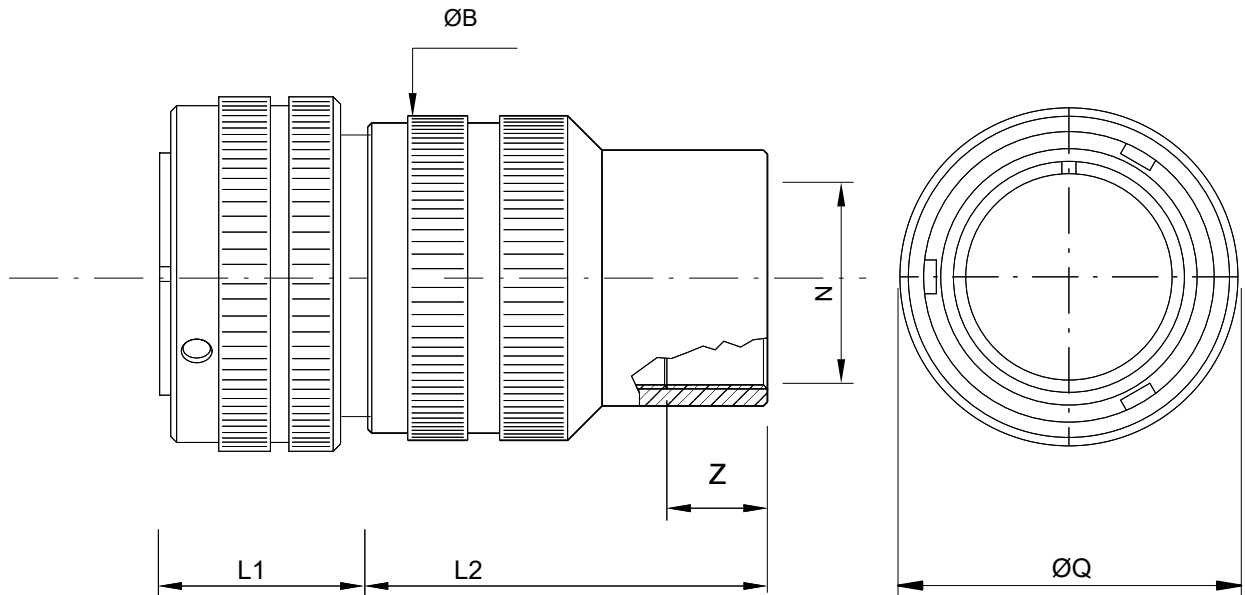
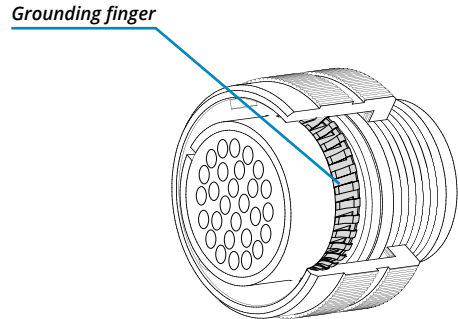

Shell size	ØQ ±0.2	ØB ±0.2	Z min	L1	N Backshell Metric thread	L2 M	N Backshell PG Thread	L2 PG
10SL	23.3	20	8	18,8	M12 - M16	32	(PG9) - PG13.5	26
14S	29.5	24	9	19,6	M12 - M16 - (M20) - (M25)	30	(PG9) - PG11 - PG13.5 - (PG16)	30
16S	33	27	9	19,6	(M16) - M20	40	PG13.5 - (PG16)	38
16	33	27	9	25,6	M20	45	-	40
18	37	30	9	24,9	M20 - M25	50	(PG11) - (PG13.5) - PG16 - PG21	50
20	41	32	9	25,3	M16 - M20 - M25 - (M32)	50	PG11-PG13.5-PG16-PG21-PG29	50
22	43	37	10	25,7	M16 - M20 - M25 - M32	50	PG13.5 - (PG16) - (PG29)	50
24	48	40	10	25,4	M20 - M25 - M32 - M40	50	PG16 - PG21 - PG29	50
28	53	45	10	25,8	(M25) - M32 - M40	63	PG21 - PG29 - PG36	60
32	60	52	10	28,3	(M25) - (M32) - M40	55	PG21 - (PG29) - PG36	60
36	66.2	58	13	28,1	M40 - M50	56	PG29 - (PG36) - (PG42)	65
40	72.4	63.8	13	28,6	M40 - (M50) - M63	65	PG29 - (PG36) - (PG42) - (PG48)	65

Dimensions in mm

Dimensions "L1 and L2" can be different from the value indicated according to backshells accessories, wires size and some special insert configurations.

(...) The threads in parentheses are versions on request with non standard backshell length (the dimensions L2 and Z are different from this page indication).
Please consult our sales office for the specific dimensions.

CVBS - Bayonet Connector with protected mating ramps

RF	CVBS		96	DA	T	20-27	S	X	M12	CR	CD5	F16		N
Series Code	Shell Material	Shell Type	Connector Class						Backshell internal thread			Shell finish		

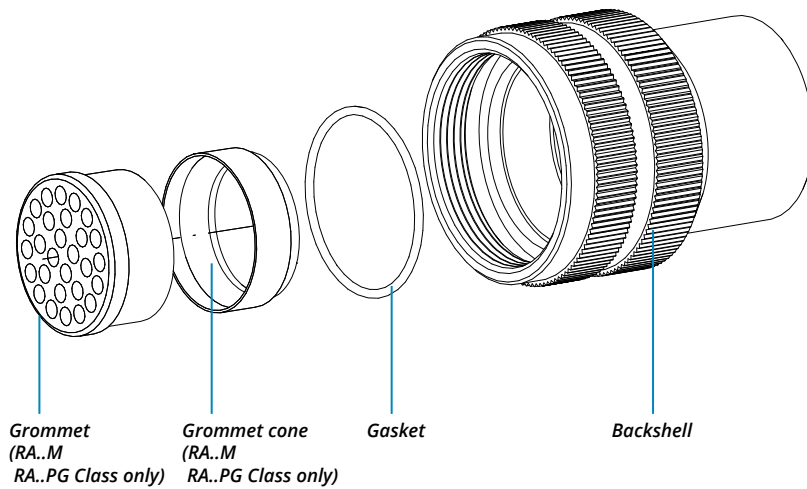

RF	Insulating material	-	Chloroprene rubber
		V	Fluoride rubber
		S	Silicone rubber
		RF	Fire resistant rubber
CVBS	Series Code	CVBS	Bayonet Connector with protected mating ramps
	Shell Material	-	Aluminum
96	Shell Type	96	Plug Connector with grounding finger
DA	Connector Class	DA	with waterproof O-ring (IP67***)
		RA	with waterproof O-ring and grommet (IP67***)
T	Connector Modification**	T	With plastic caps
20-27	Insert Arrangement		Size - Type

S	Contact Gender	S	Socket contacts
		P	Pin contacts
X	Polarization Code**		Alternate Positions
M12	Backshell internal thread	M	Provided with an internal Metric thread
		PG	Provided with an internal PG thread
CR	Contact Termination	-	Solder contacts
		CR	Crimp contacts
		LC	Less contacts
CD5	Contact Plating	-	Silver plating
		CD5	Gold plating
F16	Shell finish	F16	CCF - Black passivation (*) - conductive
N	Modification Code**	N	Consult our sales office
		S	

*** Protection degree: IP 67 (only in the mating area with mated connectors) according to EN 60529 (*) RoHS compliance (**) If required

P/N Sample: RF CVBS 96DAT 20-27SX M12 CR CD5 F16 N

CVBS - Bayonet Connector with protected mating ramps

Plug Connector (96) with Backshell Class (DA..FS - RA..FS)

Connector provided with grounding finger to guarantee shielding; with special adapter for rubber conduits. Conduit's size must be specified adding the diameter dimensions in the P/N (i.e.: CVBS 06DA...FS5040...).



Grounding finger

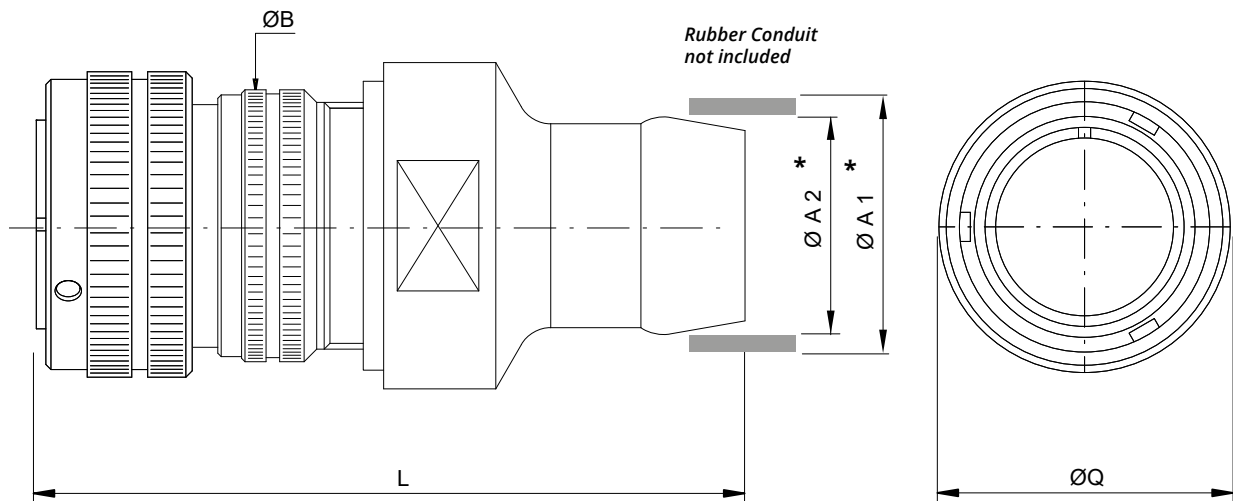
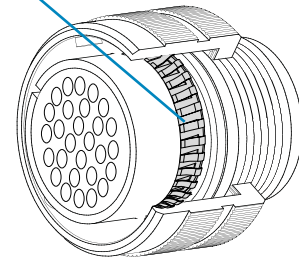

Please consult our Sales Office for further details about this dimension and according to conduit size.

Shell size	ØQ ±0.2	L max	ØB max	Backshell Conduit Size	ØA1*	ØA2*	Backshell Conduit Size	ØA1*	ØA2*
18	37	103	30	FS1712	17	12	FS3530	35	30
20	41	103	32	FS1813	18	13	FS4030	40	30
22	43	103	37	FS2015	20	15	FS4035	40	35
24	48	105	40	FS2318	23	18	FS4236	42	36
28	53	111	45	FS2520	25	20	FS4540	45	40
32	60	117	52	FS2618	26	18	FS4843	48	43
36	66.2	122	58	FS2620	26	20	FS5040	50	40
40	72.4	122	63.8	FS2722	27	22	FS5045	50	45
				FS2820	28	20	FS5550	55	50
				FS3328	33	28	FS5945	59	45

Dimensions in mm

Dimension "L" can be different from the value indicated according to backshells accessories, wires size and some special insert configurations.

CVBS - Bayonet Connector with protected mating ramps

RF	CVBS		96	DA	T	20-27	S	X	FS..	xxxx	CR	CD5	F7		N
Series Code	Shell Material	Shell Type	Connector Class					Backshell Conduits size			Shell finish				

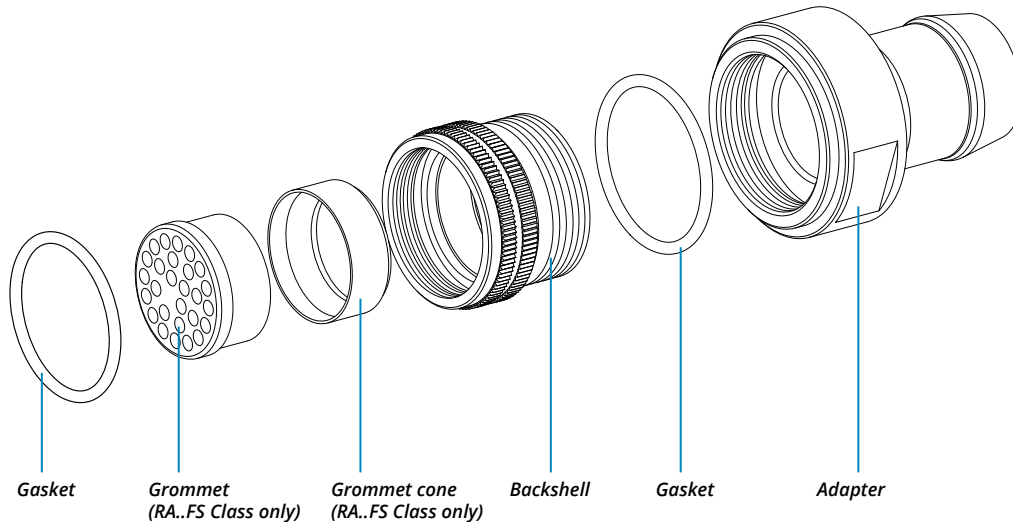

The accessories for this class are not always available in stock for all sizes; we suggest you consult our Sales Office for availability

RF	Insulating material	-	Chloroprene rubber	X	Polarization Code**	Alternate Positions	
		V	Fluoride rubber				
		S	Silicone rubber				
		RF	Fire resistant rubber				
CVBS	Series Code	CVBS	Bayonet Connector with protected mating ramps	FS..	Backshell Conduits size or internal thread	FS	Provided with a special adapter for rubber conduits
	Shell Material	-	Aluminum	xxxx	Conduit Size	xxxx	ØA1ØA2
96	Shell Type	96	Plug Connector with grounding finger	CR	Contact Termination	-	Solder contacts
						CR	Crimp contacts
						LC	Less contacts
DA	Connector Class	DA	with waterproof O-ring (IP67***)	CD5	Contact Plating	-	Silver plating
		RA	with waterproof O-ring and grommet (IP67***) #			CD5	Gold plating
T	Connector Modification**	T	With plastic caps	F7	Shell finish	F5	Electroless nickel (*)
						F7	Black epoxy varnish (*)
20-27	Insert Arrangement		Size - Type			F16	CCF - Black passivation (*) - conductive
						F26	hard anodization (*)
S	Contact Gender	S	Socket contacts	N	Modification Code**	N	Consult our sales office
		P	Pin contacts			S	

*** Protection degree: IP 67 (only in the mating area with mated connectors) according to EN 60529 (*) RoHS compliance (***) If required

P/N Sample: RF CVBS 96DAT 20-27SX FS5040 CR CD5 F7 N

(#) In some sizes the grommet cone is not needed

CVBS - Bayonet Connector with protected mating ramps

Plug Connector (96) with Backshell Class (DA..MTG - RA..MTG)

Connector provided with grounding finger to guarantee shielding; with a special adapter for clamping and retaining rubber conduits, with nut. Conduit's size must be specified adding the diameter dimensions in the P/N (i.e.: CVBS 96DA...MTG2520...).

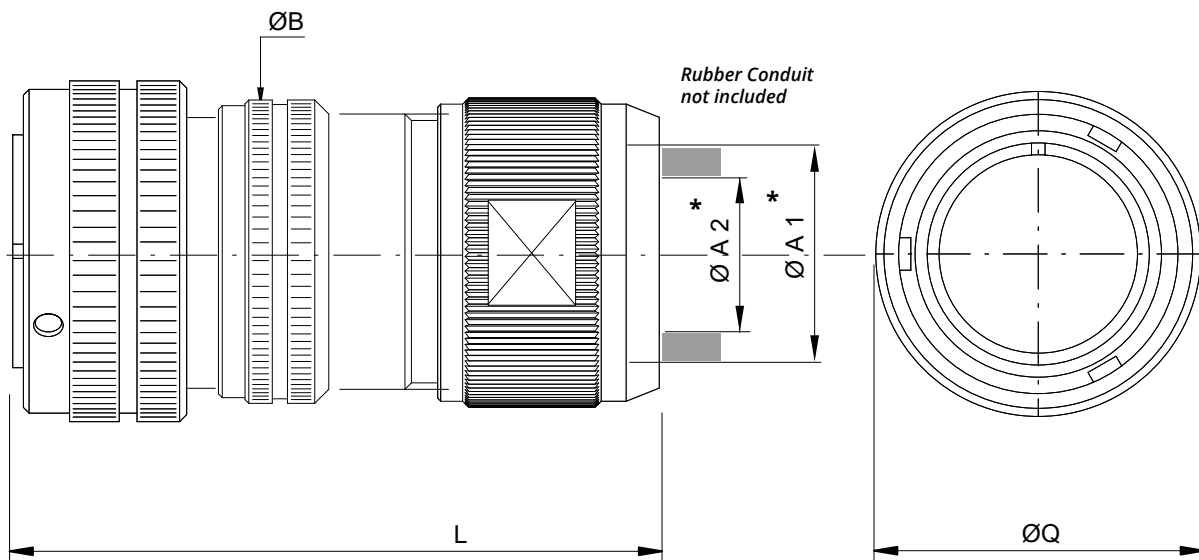
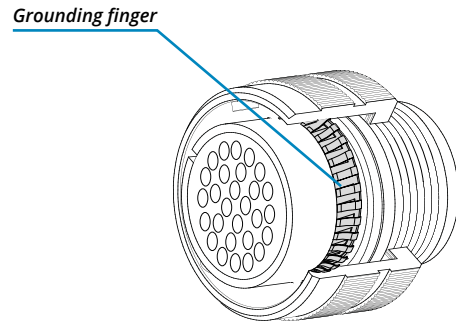

Shell size	ØQ ±0.2	L max	ØB max	Backshell Conduit Size	ØA1*	ØA2*	Shell size
18	37	101	30	MTG1712	17	12	18
20	41	101	32	MTG2015	20	15	18-24
22	43	101	37	MTG2318	23	18	24-32
24	48	107	40	MTG2520	25	20	28
28	53	110	45	MTG2924	29	24	28
32	60	114	52	MTG3328	33	28	36-32
36	66.2	120	58	MTG3530	35	30	36
40	72.4	121	63.8	MTG3628	36	28	36
				MTG3833	38	33	40
				MTG4035	40	35	40
				MTG4237	42	37	40
				MTG4238	42	38	40
				MTG4840	48	40	40

Dimensions in mm

Dimension "L" can be different from the value indicated according to backshells accessories, wires size and some special insert configurations.

* Dimensions ØA1 and ØA2 are determined by conduit size.

CVBS - Bayonet Connector with protected mating ramps



Series Shell Shell Connector
Code Material Type Class

Backshell Conduit
Conduits Size
size or
internal
thread

Shell
finish

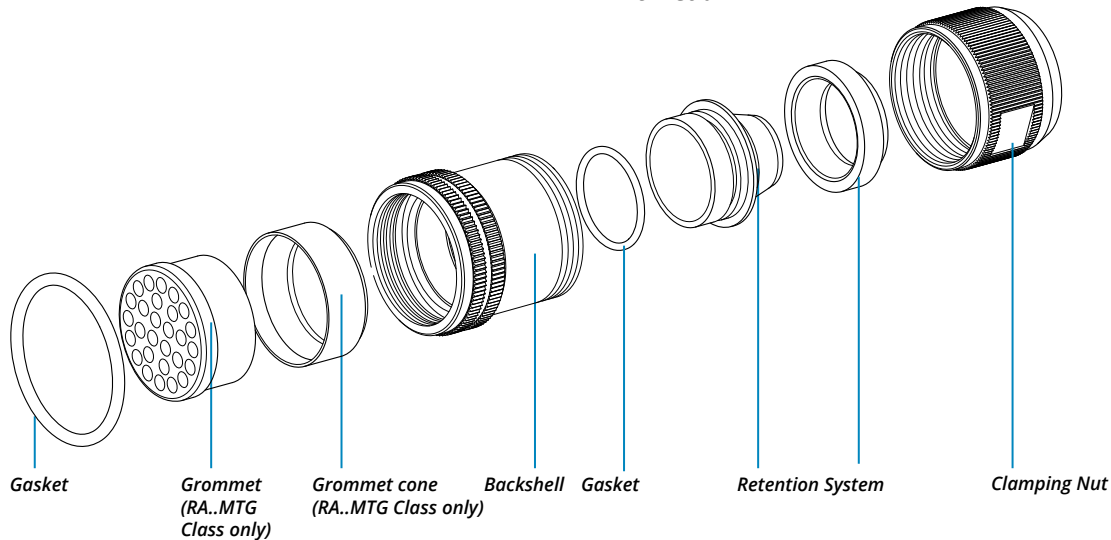

The accessories for this class are not always available in stock for all sizes; we suggest you consult our Sales Office for availability

RF	Insulating material	-	Chloroprene rubber	X	Polarization Code**	Alternate Positions	
		V	Fluoride rubber				
		S	Silicone rubber				
		RF	Fire resistant rubber				
CVBS	Series Code	CVBS	Bayonet Connector with protected mating ramps	MTG	Backshell Conduits size or internal thread	MTG	Provided with a special adapter for rubber conduits, with nut.
[]	Shell Material	-	Aluminum	2520	Conduit Size	xxxx	ØA1ØA2
96	Shell Type	96	Plug Connector with grounding finger	CR	Contact Termination	-	Solder contacts
		CR	Crimp contacts			LC	Less contacts
DA	Connector Class	DA	with waterproof O-ring (IP67***)	CD5	Contact Plating	-	Silver plating
		RA	with waterproof O-ring and grommet (IP67***) #			CD5	Gold plating
T	Connector Modification**	T	With plastic caps	F7	Shell finish	F5	Electroless nickel (*)
						F7	Black epoxy varnish (*)
20-27	Insert Arrangement		Size - Type			F16	CCF - Black passivation (*) - conductive
						F26	hard anodization (*)
S	Contact Gender	S	Socket contacts	N	Modification Code**	N	Consult our sales office
		P	Pin contacts			S	

*** Protection degree: IP 67 (only in the mating area with mated connectors) according to EN 60529 (*) RoHS compliance (***) If required

P/N Sample: RF CVBS 96DAT 20-27SX MTG2520 CR CD5 F7 N

(#) In some sizes the grommet cone is not needed

CVBS - Bayonet Connector with protected mating ramps

Plug Connector (96) with Backshell Class (AG2 - G2)

Connector provided with grounding finger to guarantee shielding;

These classes of connectors are all suitable for heat shrink tubing applications. Two piece backshell includes nut for shell tightening. Internal serration prevents backshell rotation and allows easy assembling after contacts are inserted.



Grounding finger

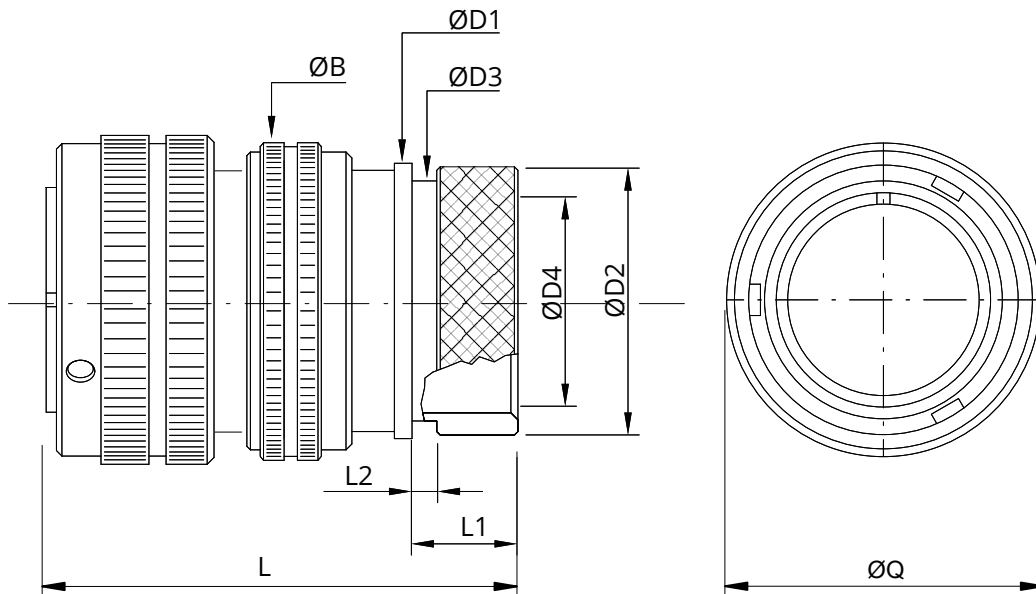
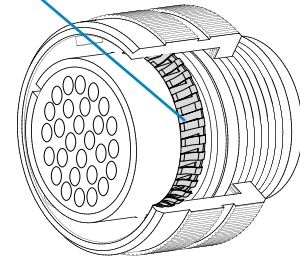

Shell size	ØQ	ØB ±0.2	ØD1 ±0.2	ØD2 ±0.2	ØD3 ±0.2	ØD4 ±0.2	L	L1 ±0.2	L2 ±0.2
10SL	23.3	22.5	17	15.5	13.3	8.6	51	11.7	3.5
14S	29.5	26	20.1	19.1	17	10.8	52	11.7	3.5
16S	33	29	23.5	23.9	21.9	14	53.5	11.7	3.5
16	33	29	23.5	23.9	21.9	14	62	11.5	3.5
18	37	33.4	26.5	23.9	21.9	14.8	61.5	11.5	3.5
20	41	37	30.2	29.6	26.2	19.3	62.5	12.4	3.5
22	43	41	33.6	29.6	26.2	22.5	62.5	12.7	3.5
24	48	45.9	36.1	37.8	34.5	28	63	12.7	3.5
28	53	51	41.4	37.8	34.5	28	65	12.7	3.5
32	60	58	50	47.8	43.4	34.8	67	15.2	3.5
36	66.2	60.5	56	47.7	43.4	38.7	67	15.2	3.5
40	72.4	69	62.4	57.6	52.4	48.2	68.5	15.2	3.5

Dimensions in mm

Dimension "L" can be different from the value indicated according to backshells accessories, wires size and some special insert configurations.

CVBS - Bayonet Connector with protected mating ramps



Series Code: **CVBS** Shell Material: [empty] Shell Type: **96** Connector Class: **G2** T: T 20-27: 20-27 S: S X: X [empty]: [empty] CR: CR CD5: CD5 Shell finish: **F7** [empty]: [empty] N: N

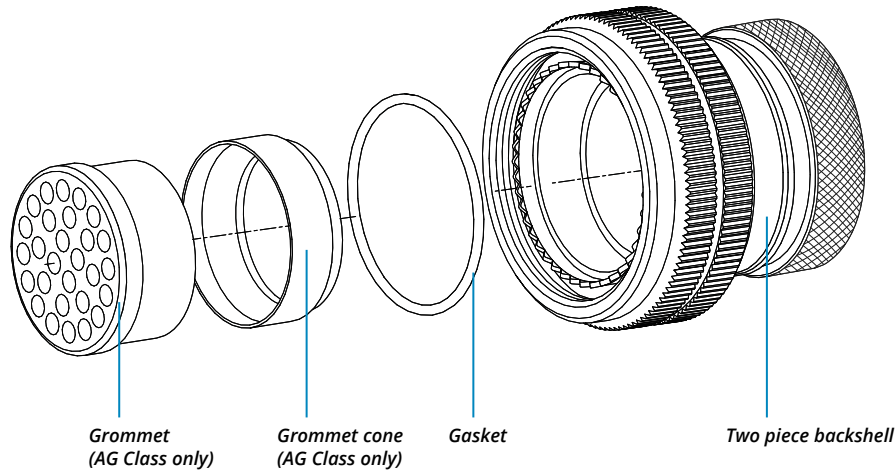

The accessories for this class are not always available in stock for all sizes; we suggest you consult our Sales Office for availability

RF	Insulating material	-	Chloroprene rubber	S	Contact Gender	S	Socket contacts
		V	Fluoride rubber			P	Pin contacts
		S	Silicone rubber				
		RF	Fire resistant rubber				
CVBS	Series Code	CVBS	Bayonet Connector with protected mating ramps	X	Polarization Code**		Alternate Positions
[empty]	Shell Material	-	Aluminum	CR	Contact Termination	-	Solder contacts
		CR	Crimp contacts			LC	Less contacts
96	Shell Type	96	Plug Connector with grounding finger	CD5	Contact Plating	-	Silver plating
		CD5	Gold plating			F5	Electroless nickel (*)
G2	Connector Class	AG2	With waterproof O-ring (IP67***)	F7	Shell finish	F7	Black epoxy varnish (*)
		G2	With waterproof O-ring and grommet (IP67***)#			F16	CCF - Black passivation (*) - conductive
T	Connector Modification**	T	With plastic caps			F26	hard anodization (*)
20-27	Insert Arrangement		Size - Type	N	Modification Code**	N	Consult our sales office
						S	Consult our sales office

*** Protection degree: IP 67 (only in the mating area with mated connectors) according to EN 60529

(*) RoHS compliance (***) If required

P/N Sample: RF CVBS 96G2T 20-27SX CR CD5 F7 N

(#) In some sizes the grommet cone is not needed

CVBS - Bayonet Connector with protected mating ramps

Plug Connector (96) with Backshell Class (ASB1 - SB1)

Connector provided with grounding finger to guarantee shielding;
 Backshell for multicore jacketed shielded cables, provided with MS 3057...C type Cable-Clamp. (for jacketed cable)
 Also available versions for over/under dimensioned cables.

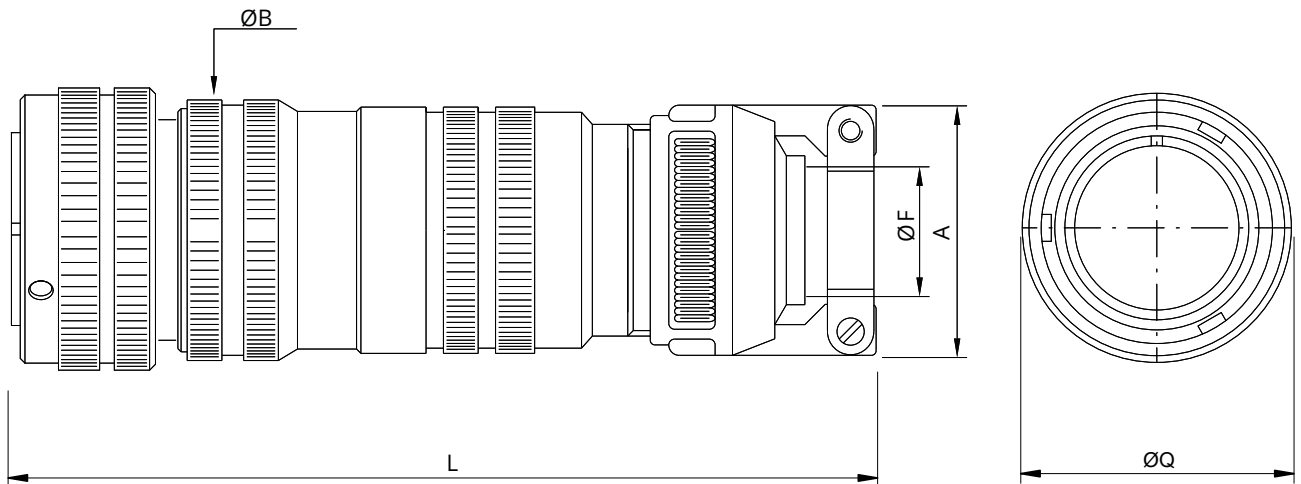
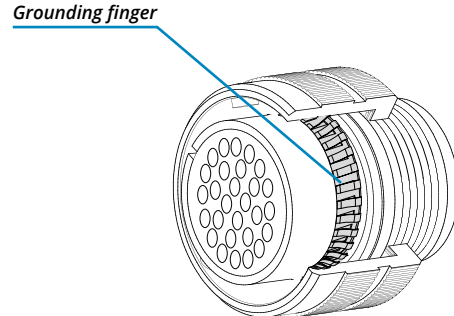

Shell size	ØQ Max	ØB ±0.2	L	A ±0.2	ØF cable dimension	
					Min	Max
10SL	23.3	20	100	23	2.4	7.9
14S	29.5	24	100	26	5.8	11.2
16S	33	27	101	28.5	8	13.5
16	33	27	120	28.5	8	13.5
18	37	32	125	32	9.6	15.9
20	41	35	125	37.5	11.3	19
22	43	37	126	37.5	11.3	19
24	48	42	135	43.5	15.5	23.8
28	53	45	138	43.5	15.5	23.8
32	60	50	145	54	23.4	31.8
36	66.2	58	150	58	25.4	35
40	72.4	63.8	155	63.5	30	41.3

Dimensions in mm

Dimension "L" can be different from the value indicated according to backshells accessories, wires size and some special insert configurations.

CVBS - Bayonet Connector with protected mating ramps

RF	CVBS		96	ASB1	T	20-27	S	X		CR	CD5	F7		N
Series Code	Shell Material	Shell Type	Connector Class									Shell finish		

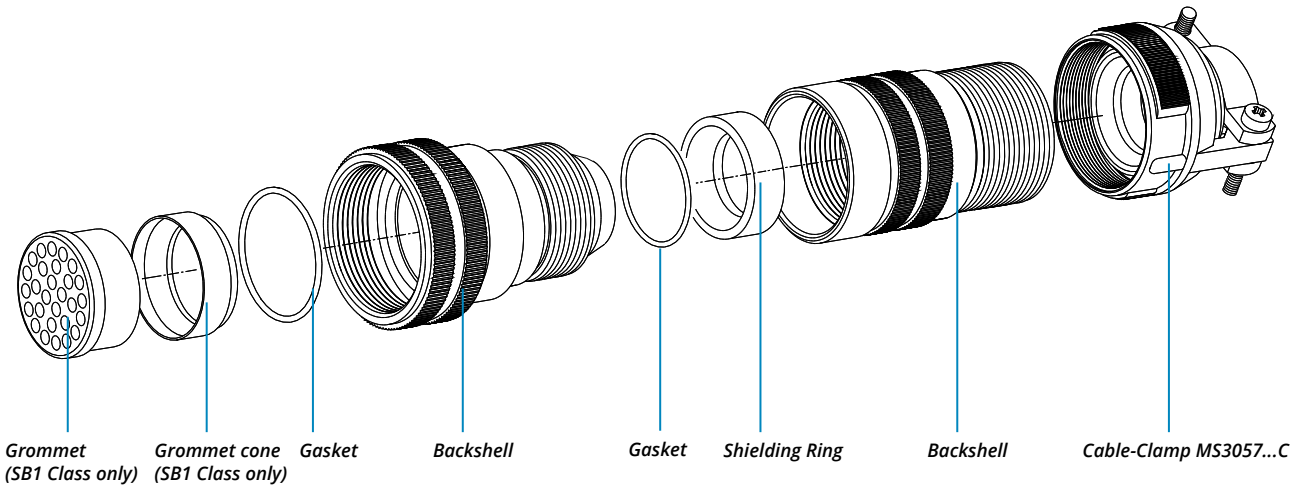

The accessories for this class are not always available in stock for all sizes; we suggest you consult our Sales Office for availability

RF	Insulating material	-	Chloroprene rubber	S	Contact Gender	S	Socket contacts		
		V	Fluoride rubber			P	Pin contacts		
		S	Silicone rubber		X	Polarization Code**	Alternate Positions		
		RF	Fire resistant rubber						
CVBS	Series Code	CVBS	Bayonet Connector with protected mating ramps	CR	Contact Termination	-	Solder contacts		
	Shell Material	-	Aluminum			CR	Crimp contacts		
	Shell Type	96	Plug Connector with grounding finger			LC	Less contacts		
ASB1	Connector Class	ASB1	with waterproof O-ring (IP67)	CD5	Contact Plating	-	Silver plating		
		SB1	with waterproof O-ring and grommet (IP67)#			CD5	Gold plating		
		T	Connector Modification**			T	With plastic caps	F7	Shell finish
20-27	Insert Arrangement				Size - Type	F7	Black epoxy varnish (*)		
						F16	CCF - Black passivation (*) - conductive		
N	Modification Code**	N	Consult our sales office	S		F26	hard anodization (*)		
		S							

P/N Sample: RF CVBS 96SB1T 20-27SX CR CD5 F7 N

(*) RoHS compliance

(**) If required

(#) In some sizes the grommet cone is not needed

CVBS - Bayonet Connector with protected mating ramps

Plug Connector (96) with Backshell Class (AGV - GV)

Connector provided with grounding finger to guarantee shielding; These classes of connectors are provided with backshell for shield hose and heat shrink tubing termination. It comes complete with conical protection spring, also suitable for thin shield braid.



Grounding finger

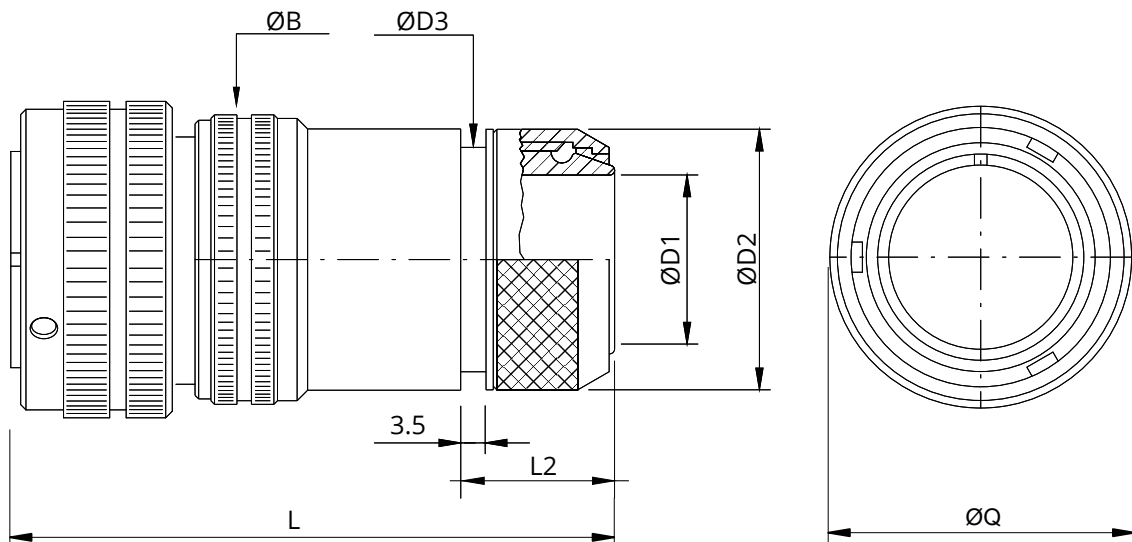
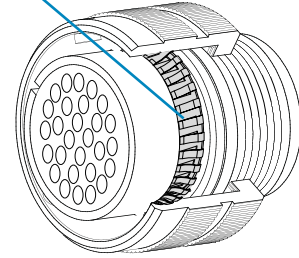

Shell size	ØQ Max	ØB ±0.2	ØD1 ±0.2	ØD2 ±0.2	ØD3 ±0.2	L	L2 ±0.2
10SL	23.3	20	8.6	18.5	16.3	66	18
14S	29.5	24	10.6	22	20	66	17.6
16S	33	27	10.4	25	23	66	20.7
16	33	27	13.5	25	23	75.5	20.8
18	37	30	14.5	28	24.5	75.5	20.8
20	41	32	18.4	32	28.5	75.5	20.8
22	43	37	20.7	34	30.5	75.5	20.8
24	48	40	24.6	38.5	34.5	81	20.7
28	53	46	25	40	36	81	21.8
32	60	52	33.3	48	44	82	20.7
36	66.2	58	38.5	55	51	82	20.7
40	72.4	63.8	46	62	58	83	21.8

Dimensions in mm

Dimension "L" can be different from the value indicated according to backshells accessories, wires size and some special insert configurations.

CVBS - Bayonet Connector with protected mating ramps



Series Shell Shell Connector
Code Material Type Class

Shell
finish

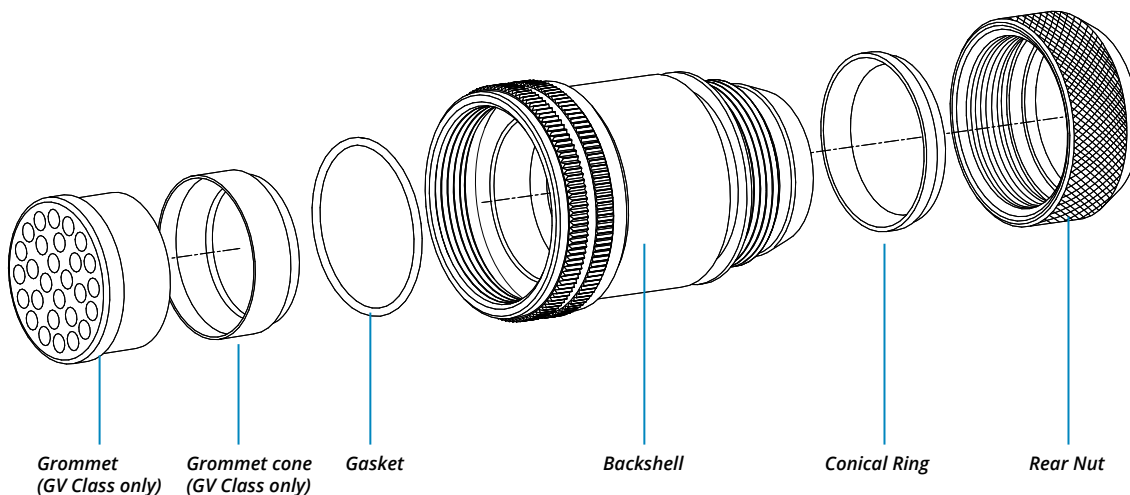

The accessories for this class are not always available in stock for all sizes; we suggest you consult our Sales Office for availability

RF	Insulating material	-	Chloroprene rubber	X	Polarization Code**		Alternate Positions		
		V	Fluoride rubber						
		S	Silicone rubber						
		RF	Fire resistant rubber						
CVBS	Series Code	CVBS	Bayonet Connector with protected mating ramps	CR	Contact Termination	-	Solder contacts		
						CR	Crimp contacts		
						LC	Less contacts		
	Shell Material	-	Aluminum	CD5	Contact Plating	-	Silver plating		
						CD5	Gold plating		
96	Shell Type	96	Plug Connector with grounding finger	F7	Shell finish	F5	Electroless nickel (*)		
								F7	Black epoxy varnish (*)
								F16	CCF - Black passivation (*) - conductive
								F26	hard anodization (*)
GV	Connector Class	AGV	With waterproof O-ring (IP67***)	N	Modification Code**	N	Consult our sales office		
		GV	with waterproof O-ring and grommet (IP67***)						
20-27	Insert Arrangement		Size - Type			S			
S	Contact Gender	S	Socket contacts						
		P	Pin contacts						

*** Protection degree: IP 67 (only in the mating area with mated connectors) according to EN 60529 (*) RoHS compliance (***) If required

P/N Sample: RF CVBS 96GVT 20-27SX CR CD5 F7 N

CVBS - Bayonet Connector with protected mating ramps

Plug Connector (96) with Backshell Class (SB)

Connector provided with grounding finger to guarantee shielding; These classes of connectors are provided with backshell for shield hose and heat shrink tubing termination. It comes complete with conical protection spring, also suitable for thin shield braid. Two piece backshell includes nut for shell tightening. Internal serration prevents backshell rotation and allows easy assembling after contacts are inserted.

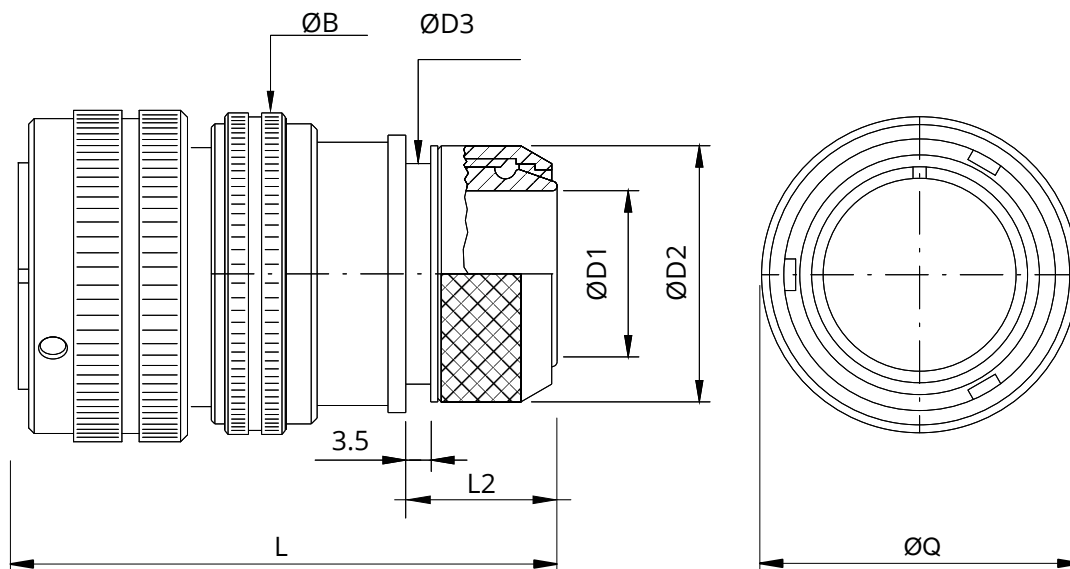
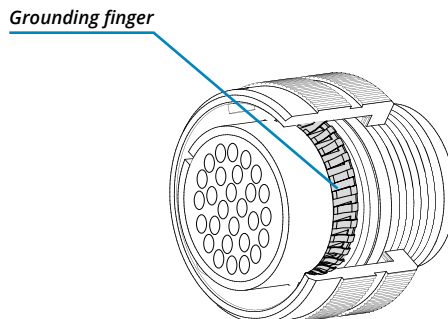

Shell size	ØQ Max	ØB ±0.2	ØD1 ±0.2	ØD2 ±0.2	ØD3 ±0.2	L	L2 ±0.2
10SL	23.3	22.5	8.6	18.5	16.3	56	18
14S	29.5	26.1	10.6	22	20	56	17.6
16S	33	29	10.4	25	23	56	20.7
16	33	29	13.5	25	23	69	20.8
18	37	33.5	14.5	28	24.5	70	20.8
20	41	37	18.4	32	28.5	71	20.8
22	43	41	20.7	34	30.5	71	20.8
24	48	46	24.6	38.5	34.5	73	20.7
28	53	51	25	40	36	75	21.8
32	60	58	33.3	48	44	75	20.7
36	66.2	61	38.5	55	51	75	20.7
40	72.4	69	46	62	58	76	21.8

Dimensions in mm

Dimension "L" can be different from the value indicated according to backshells accessories, wires size and some special insert configurations.

CVBS - Bayonet Connector with protected mating ramps



Series Shell Shell Connector
Code Material Type Class

Shell
finish

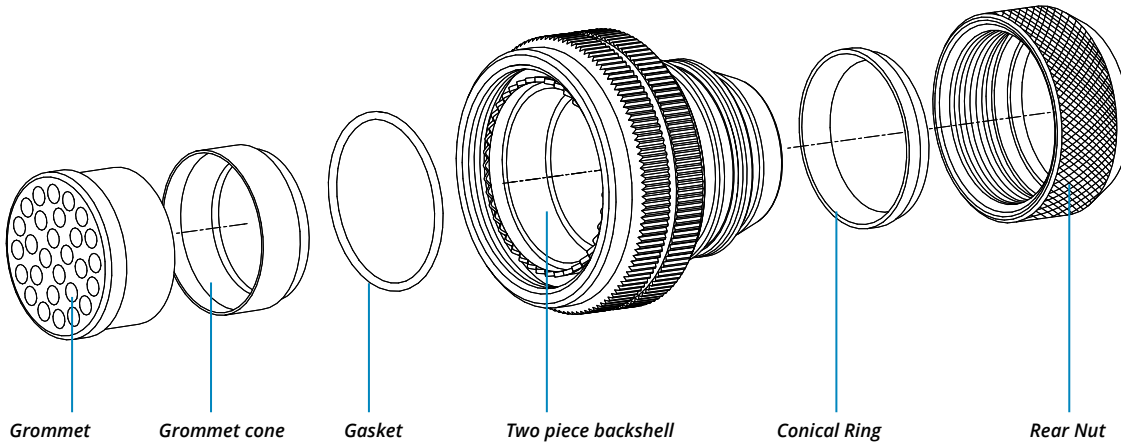

The accessories for this class are not always available in stock for all sizes; we suggest you consult our Sales Office for availability

RF	Insulating material	-	Chloroprene rubber	S	Contact Gender	S	Socket contacts
		V	Fluoride rubber			P	Pin contacts
		S	Silicone rubber				
		RF	Fire resistant rubber				
CVBS	Series Code	CVBS	Bayonet Connector with protected mating ramps	X	Polarization Code**		Alternate Positions
	Shell Material	-	Aluminum	CR	Contact Termination	-	Solder contacts
				CR		CR	Crimp contacts
				LC		LC	Less contacts
96	Shell Type	96	Plug Connector with grounding finger	CD5	Contact Plating	-	Silver plating
				CD5		CD5	Gold plating
SB	Connector Class	SB	With waterproof O-ring and grommet (IP67***)#	F7	Shell finish	F5	Electroless nickel (*)
						F7	Black epoxy varnish (*)
						F16	CCF - Black passivation (*) - conductive
						F26	hard anodization (*)
T	Connector Modification**	T	With plastic caps	N	Modification Code**	N	Consult our sales office
						S	
20-27	Insert Arrangement		Size - Type				

*** Protection degree: IP 67 (only in the mating area with mated connectors) according to EN 60529 (*) RoHS compliance (***) If required

P/N Sample: RF CVBS 96SBT 20-27SX CR CD5 F7 N

(#) In some sizes the grommet cone is not needed

CVBS - Bayonet Connector with protected mating ramps

Plug Connector (96) with Backshell Class (AMK - MK)

Connector provided with grounding finger to guarantee shielding;

Connectors provided with gasket and iris spring connected to one another by an internal ring. The iris spring is used to connect multicore jacketed cables or jacketed hoses. An additional gasket added outside of the central body guarantees the complete watertightness. Clamping range on the dimension table has to be chosen according to the cable size and its shielding and specified in the connector P/N.



Grounding finger

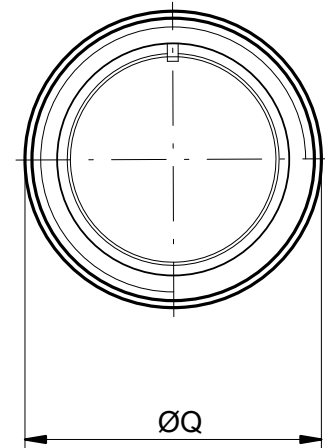
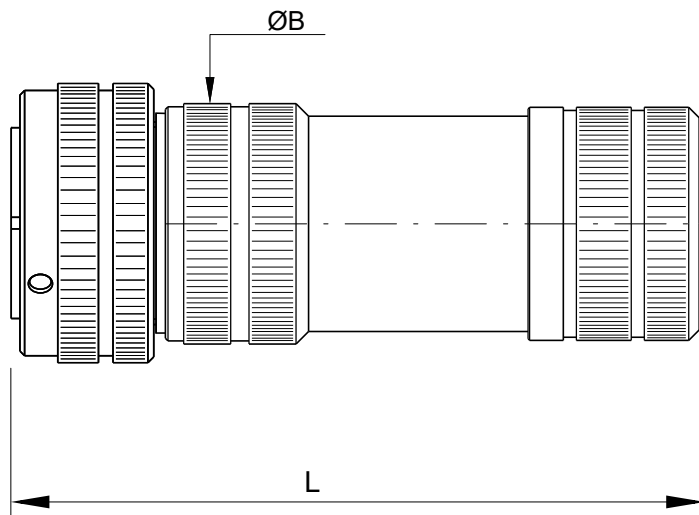
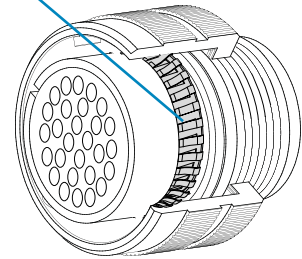

Shell size	ØQ	ØB	L
10SL	23.3	20	116
14S	29.5	24	116
16S	33	27	116
16	33	27	148
18	37	30	151
20	41	32	151
22	43	37	151
24	48	40	154
28	53	45	154
32	60	52	158
36	66.2	58	162
40	72.4	63.8	167

Dimensions in mm

Dimension "L" can be different from the value indicated according to backshells accessories, wires size and some special insert configurations.

Type *	Clamping Range **	
	max	min
01	6	3
02	9.5	5
03	13	8.5
04	16.5	12
05	20	15.5
06	23.5	19
07	27	22.5
08	30.5	26
09	34	29.5
10	37.5	33
11	41	36.5
12	44.5	40
13	48	43.5
14	51.5	47

* Must be specified in the connector

** Clamping range to be verified with cable section. Please consult our Sales Office.

CVBS - Bayonet Connector with protected mating ramps



Series Code

Shell Type

Clamping Range

Shell finish

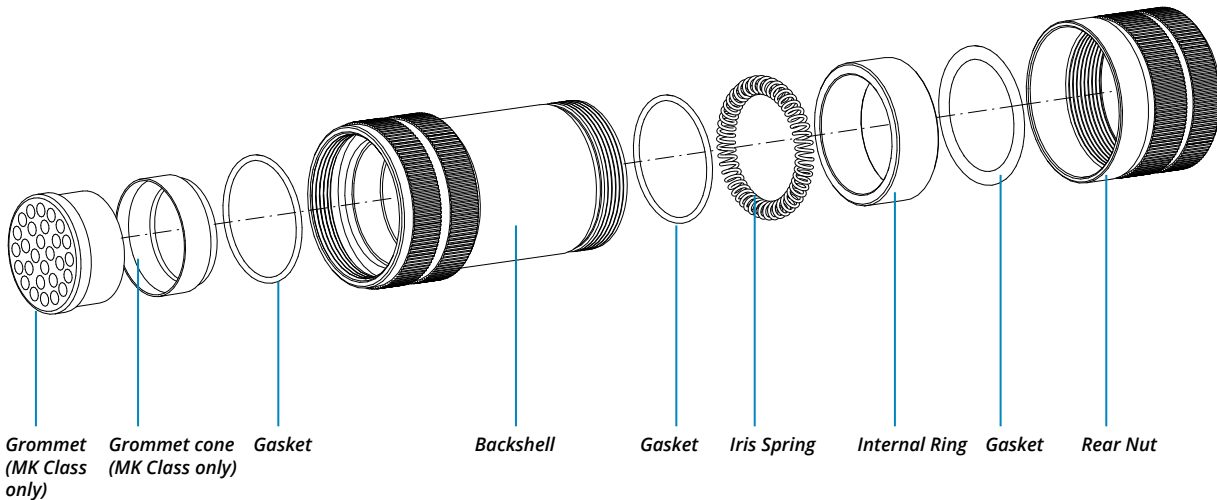

The accessories for this class are not always available in stock for all sizes; we suggest you consult our Sales Office for availability

RF	Insulating material	-	Chloroprene rubber	20-27	Insert Arrangement	Size - Type	
		V	Fluoride rubber		S	S	Socket contacts
		S	Silicone rubber			P	Pin contacts
CVBS	Series Code	CVBS	Bayonet Connector with protected mating ramps	X	Polarization Code**		Alternate Positions
		RF	Fire resistant rubber	CR	Contact Termination	-	Solder contacts
	Shell Material	-	Aluminum			CR	Crimp contacts
96	Shell Type	96	Plug Connector with grounding finger			LC	Less contacts
MK	Connector Class	AMK	with waterproof O-ring (IP67***)	CD5	Contact Plating	-	Silver plating
		MK	With waterproof O-ring and grommet (IP67***)#			CD5	Gold plating
xx	Clamping Range	xx	Type	F7	Shell finish	F5	Electroless nickel (*)
T	Connector Modification**	T	With plastic caps			F7	Black epoxy varnish (*)
						F16	CCF - Black passivation (*) - conductive
						F26	hard anodization (*)
				N	Modification Code**	N	Consult our sales office
						S	

*** Protection degree: IP 67 (only in the mating area with mated connectors) according to EN 60529

(*) RoHS compliance (***) If required

P/N Sample: RF CVBS 96MKT01 20-27SX CR CD5 F7 N

(#) In some sizes the grommet cone is not needed

CVBS - Bayonet Connector with protected mating ramps

Plug Connector (08) with 90° Elbow Class (A - DA - RA)

Connector with 90° elbow provided with an external thread suitable for MS3057...A or C type Cable-Clamps (to be ordered separately).

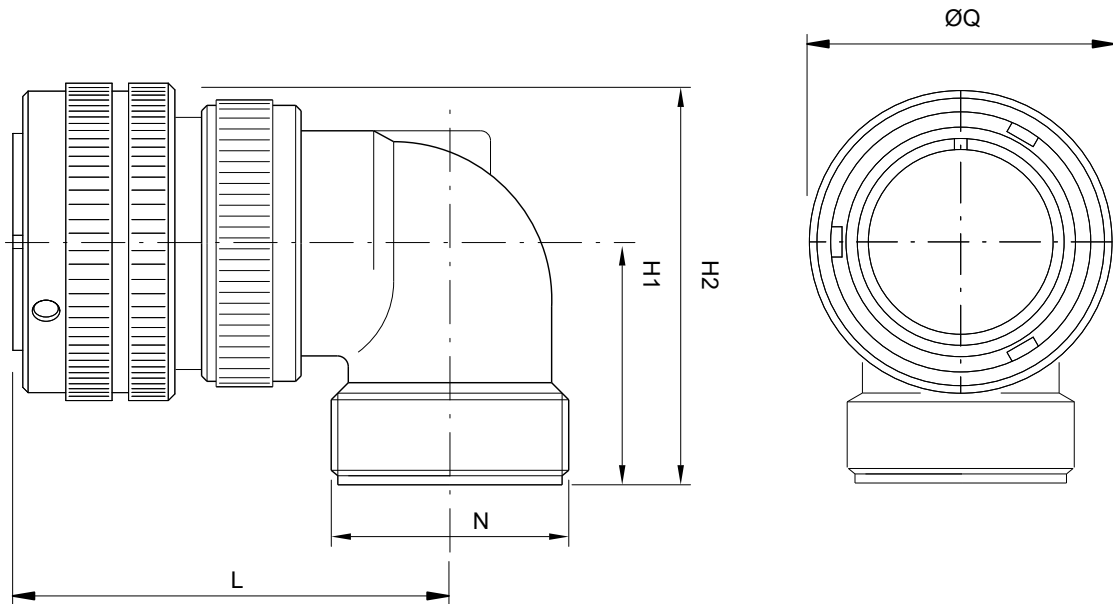

Shell size	ØQ ±0.2	L max	H1 max	H2 max	N Backshell Thread in inches
10SL	23.3	45.5	27	38.7	5/8"-24 UNEF
14S	29.5	45.5	27	41.3	3/4"-20 UNEF
16S	33	47	29	44.9	7/8"-20 UNEF
16	33	56.5	29	44.9	7/8"-20 UNEF
18	37	57.5	31	48.1	1"-20 UNEF
20	41	60	33	51.7	1" 3/16-18 UNEF
22	43	62.5	35	55.3	1" 3/16-18 UNEF
24	48	65.5	38	59.8	1" 7/16-18 UNEF
28	53	65.5	40	65	1" 7/16-18 UNEF
32	60	70	46	74.1	1" 3/4-18 UNS
36	66.2	73.5	49	80.3	2"-18 UNS
40	72.4	78.5	53	87.6	2" 1/4-16 UN

Dimensions in mm

Dimension "L" can be different from the value indicated according to backshells accessories, wires size and some special insert configurations.

CVBS - Bayonet Connector with protected mating ramps

RF	CVBS		08	DA	T	20-27	S	X		CR	CD5	F7		N
Series Code		Shell Type		Connector Class								Shell finish		

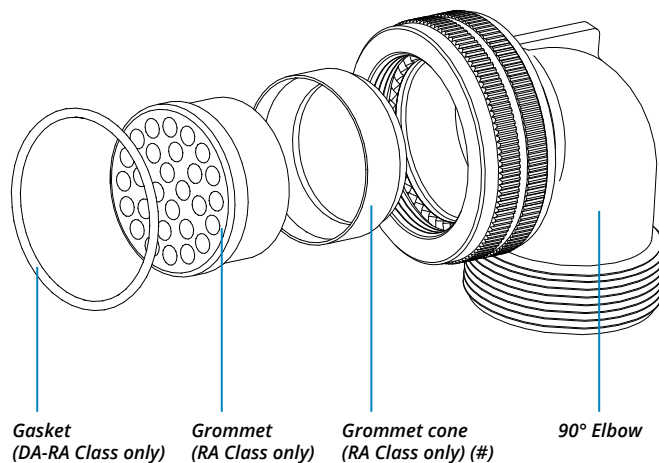

RF	Insulating material	-	Chloroprene rubber
		V	Fluoride rubber
		S	Silicone rubber
		RF	Fire resistant rubber
CVBS	Series Code	CVBS	Bayonet Connector with protected mating ramps
	Shell Material	-	Aluminum
08	Shell Type	08	Plug Connector with 90° elbow
DA	Connector Class	A	non watertight
		DA	with waterproof O-ring (IP67***)
		RA	with waterproof O-ring and grommet (IP67***) (#)
T	Connector Modification**	T	With plastic caps
20-27	Insert Arrangement		Size - Type

S	Contact Gender	S	Socket contacts
		P	Pin contacts
X	Polarization Code**		Alternate Positions
CR	Contact Termination	-	Solder contacts
		CR	Crimp contacts
		LC	Less contacts
CD5	Contact Plating	-	Silver plating
		CD5	Gold plating
F7	Shell finish	F5	Electroless nickel (*)
		F7	Black epoxy varnish (*)
		F16	CCF - Black passivation (*) - conductive
N	Modification Code**	N	Consult our sales office
		S	

*** Protection degree: IP 67 (only in the mating area with mated connectors) according to EN 60529 (*) RoHS compliance (**) If required

P/N Sample: RF CVBS 08DAT 20-27SX CR CD5 F7 N

(#) In some sizes the grommet cone is not needed

CVBS - Bayonet Connector with protected mating ramps

Plug Connector (08) with 90° Elbow Class (AF - F)

Connector with 90° elbow provided with MS3057...A type Cable-Clamp and bushing MS3420... (for single wire)

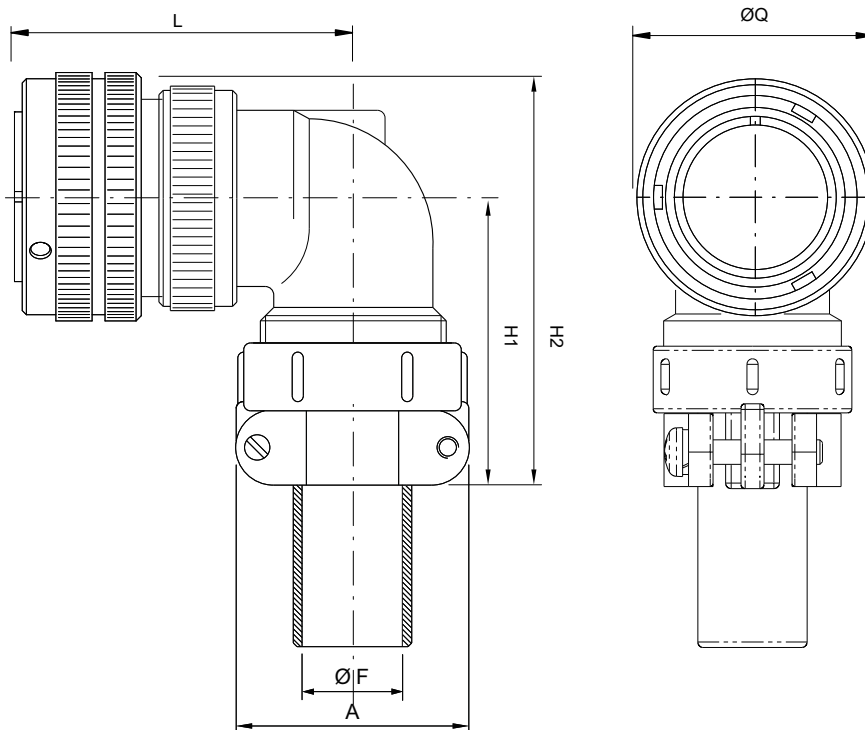

Shell size	ØQ ±0.2	L max	H1 max	H2 max	A max	ØF cable max dimension
10SL	23.3	45.5	39	50.7	22.5	5.6
14S	29.5	45.5	39	53.3	28	7.9
16S	33	47	42.5	58.4	30	11
16	33	56.5	42.5	58.4	30	11
18	37	57.5	47	64.1	31.7	14.2
20	41	60	47.5	66.2	37.5	15.8
22	43	62.5	49.5	69.8	37.5	15.8
24	48	65.5	53.5	75.3	43.5	19
28	53	65.5	55.5	80.5	43.5	19
32	60	70	61.5	89.6	51.7	23.8
36	66.2	73.5	64.5	95.8	58.5	31.7
40	72.4	78.5	82	116.6	68.5	34.9

Dimensions in mm

Dimension "L" can be different from the value indicated according to backshells accessories, wires size and some special insert configurations.

CVBS - Bayonet Connector with protected mating ramps

RF	CVBS		08	AF	T	20-27	S	X		CR	CD5	F7		N
Series Code	Series Code		Shell Type	Connector Class								Shell finish		

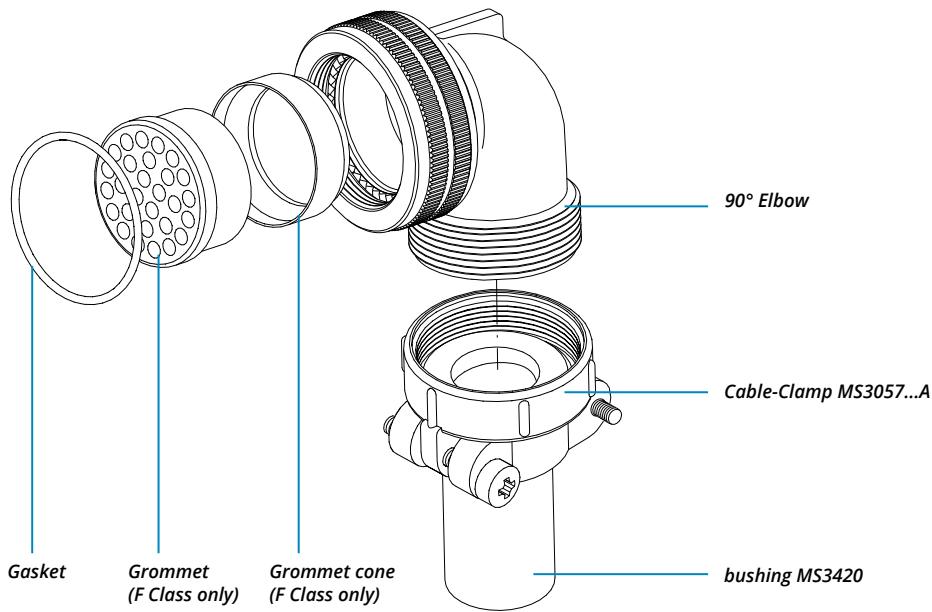

RF	Insulating material	-	Chloroprene rubber
		V	Fluoride rubber
		S	Silicone rubber
		RF	Fire resistant rubber
CVBS	Series Code	CVBS	Bayonet Connector with protected mating ramps
	Shell Material	-	Aluminum
08	Shell Type	08	Plug Connector with 90° elbow
AF	Connector Class	AF	with waterproof O-ring (IP54)
		F	with waterproof O-ring and grommet (IP54) (#)
T	Connector Modification**	T	With plastic caps
20-27	Insert Arrangement		Size - Type

S	Contact Gender	S	Socket contacts
		P	Pin contacts
X	Polarization Code**		Alternate Positions
CR	Contact Termination	-	Solder contacts
		CR	Crimp contacts
		LC	Less contacts
CD5	Contact Plating	-	Silver plating
		CD5	Gold plating
F7	Shell finish	F5	Electroless nickel (*)
		F7	Black epoxy varnish (*)
		F16	CCF - Black passivation (*) - conductive
N	Modification Code**	N	Consult our sales office
		S	

(#) In some sizes the grommet cone is not needed
 (*) RoHS compliance (**) If required

P/N Sample: RF CVBS 08AFT 20-27SX CR CD5 F7 N

CVBS - Bayonet Connector with protected mating ramps

Plug Connector (08) with 90° Elbow Class (AC - ACF)

Connector with 90° elbow provided with MS3057...C type Cable-Clamp (for jacketed cable)

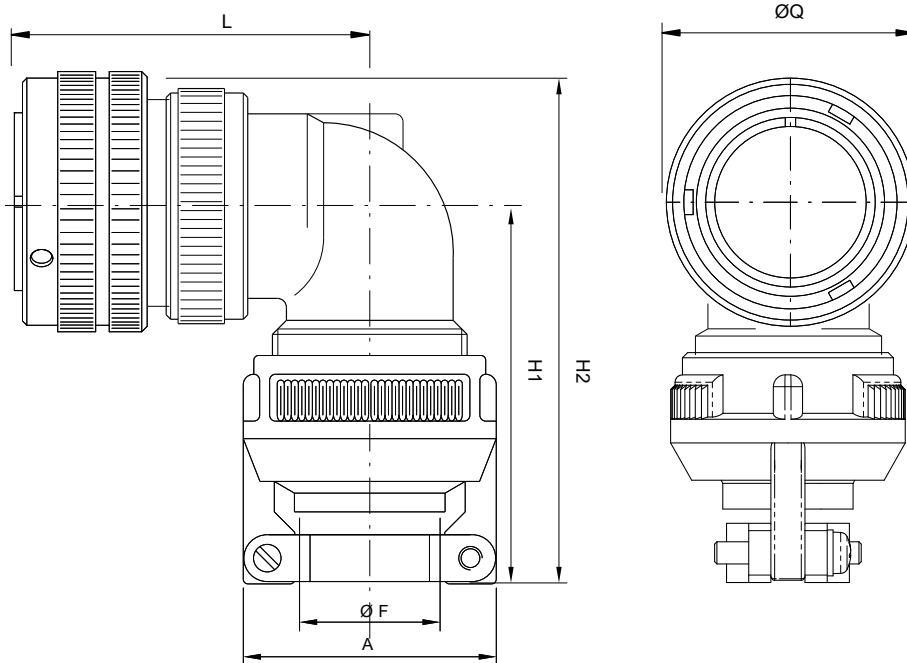

Shell size	ØQ ±0.2	L max	H1 max	H2 max	A max	ØF max cable dimension	
						Min	Max
10SL	23.3	45.5	51	62.7	23	2.4	7.9
14S	29.5	45.5	51	65.3	26	5.8	11.2
16S	33	47	54	69.9	28.5	8	13.5
16	33	56.5	54	69.9	28.5	8	13.5
18	37	57.5	58.5	75.6	32	9.6	15.9
20	41	60	59.5	78.2	37.5	11.3	19
22	43	62.5	61.5	81.8	37.5	11.3	19
24	48	65.5	71.5	93.3	43.5	15.5	23.8
28	53	65.5	73.5	98.5	43.5	15.5	23.8
32	60	70	84	112.1	54	23.4	31.8
36	66.2	73.5	91.5	122.8	58	25.4	35
40	72.4	78.5	98	132.6	63.5	30	41.3

Dimensions in mm

Dimension "L" can be different from the value indicated according to backshells accessories, wires size and some special insert configurations.

CVBS - Bayonet Connector with protected mating ramps

RF	CVBS		08	ACF	T	20-27	S	X		CR	CD5	F7		N
Series Code		Shell Type		Connector Class								Shell finish		

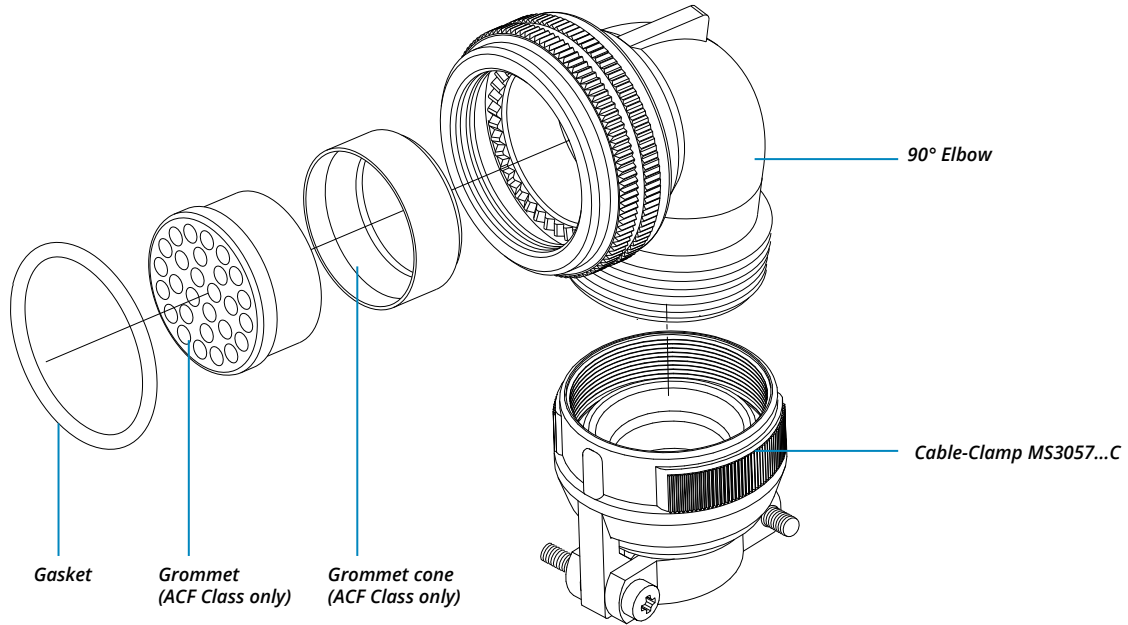

RF	Insulating material	-	Chloroprene rubber
		V	Fluoride rubber
		S	Silicone rubber
		RF	Fire resistant rubber
CVBS	Series Code	CVBS	Bayonet Connector with protected mating ramps
	Shell Material	-	Aluminum
08	Shell Type	08	Plug Connector with 90° elbow
ACF	Connector Class	AC	with waterproof O-ring (IP67)
		ACF	with waterproof O-ring and grommet (IP67) (#)
T	Connector Modification**	T	With plastic caps
20-27	Insert Arrangement		Size - Type

S	Contact Gender	S	Socket contacts
		P	Pin contacts
X	Polarization Code**		Alternate Positions
CR	Contact Termination	-	Solder contacts
		CR	Crimp contacts
		LC	Less contacts
CD5	Contact Plating	-	Silver plating
		CD5	Gold plating
F7	Shell finish	F5	Electroless nickel (*)
		F7	Black epoxy varnish (*)
		F16	CCF - Black passivation (*) - conductive
N	Modification Code**	N	Consult our sales office
		S	

(#) In some sizes the grommet cone is not needed

(*) RoHS compliance (***) If required

P/N Sample: RF CVBS 08ACFT 20-27SX CR CD5 F7 N

CVBS - Bayonet Connector with protected mating ramps

Plug Connector (08) with 90° Elbow Class (ACB)

Connector with 90° elbow provided with MS3057...C type Cable-Clamp and bushing MS 3420A (for jacketed cable)

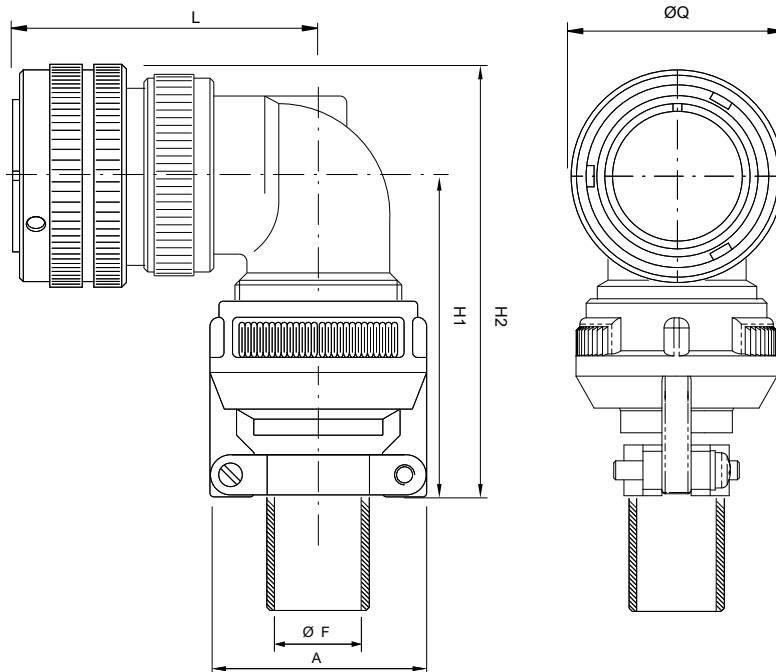

Shell size	ØQ ±0.2	L max	H1 max	H2 max	A max	ØF max cable dimension
10SL	23.3	45.5	51	62.3	23	5.6
14S	29.5	45.5	51	65.3	26	7.9
16S	33	47	54	69.9	28.5	11.1
16	33	56.5	54	69.9	28.5	11.1
18	37	57.5	58.5	75.6	32	11.1
20	41	60	59.5	78.2	37.5	13.7
22	43	62.5	61.5	81.8	37.5	13.7
24	48	65.5	71.5	93.3	43.5	19
28	53	65.5	73.5	98.5	43.5	19
32	60	70	84	112.1	54	23.8
36	66.2	73.5	91.5	122.8	58	28.5
40	72.4	78.5	98	132.6	63.5	31.8

Dimensions in mm

Dimension "L" can be different from the value indicated according to backshells accessories, wires size and some special insert configurations.

CVBS - Bayonet Connector with protected mating ramps

RF	CVBS		08	ACB	T	20-27	S	X		CR	CD5	F7		N
Series Code	Series Code		Shell Type	Connector Class								Shell finish		

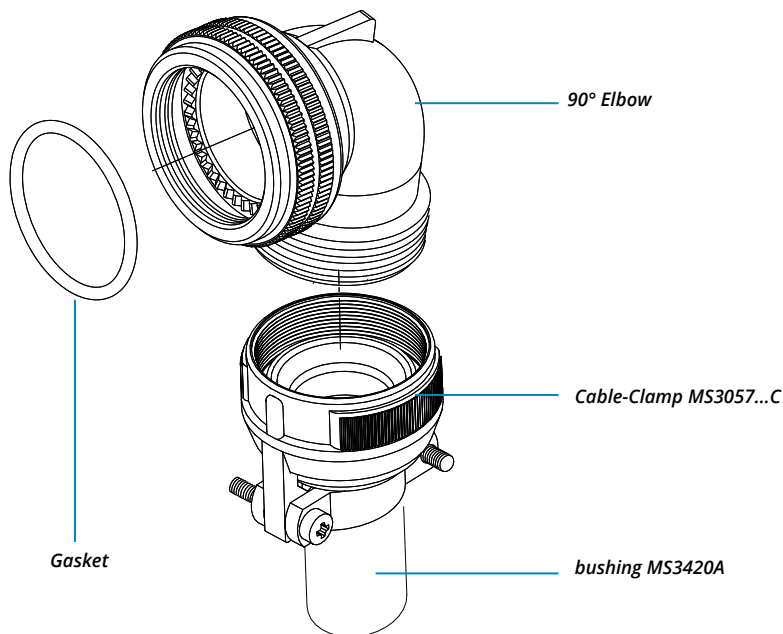

RF	Insulating material	-	Chloroprene rubber	S	Contact Gender	S	Socket contacts
		V	Fluoride rubber			P	Pin contacts
		S	Silicone rubber				
		RF	Fire resistant rubber				
CVBS	Series Code	CVBS	Bayonet Connector with protected mating ramps	X	Polarization Code**		Alternate Positions
	Shell Material	-	Aluminum	CR	Contact Termination	-	Solder contacts
						CR	Crimp contacts
						LC	Less contacts
08	Shell Type	08	Plug Connector with 90° elbow	CD5	Contact Plating	-	Silver plating
ACB	Connector Class	ACB	with waterproof O-ring			CD5	Gold plating
				F7	Shell finish	F5	Electroless nickel (*)
						F7	Black epoxy varnish (*)
						F16	CCF - Black passivation (*) - conductive
T	Connector Modification**	T	With plastic caps	N	Modification Code**	N	Consult our sales office
				S		S	Consult our sales office
20-27	Insert Arrangement		Size - Type				

P/N Sample: RF CVBS 08ACBT 20-27SX CR CD5 F7 N

(*) RoHS compliance

(**) If required

CVBS - Bayonet Connector with protected mating ramps

Plug Connector (08) with 90° Elbow Class (DA...M - RA...M - DA...PG - RA...PG)

Connector with 90° elbow provided with an internal Metric or PG thread suitable for Cable Glands or conduit adapters.

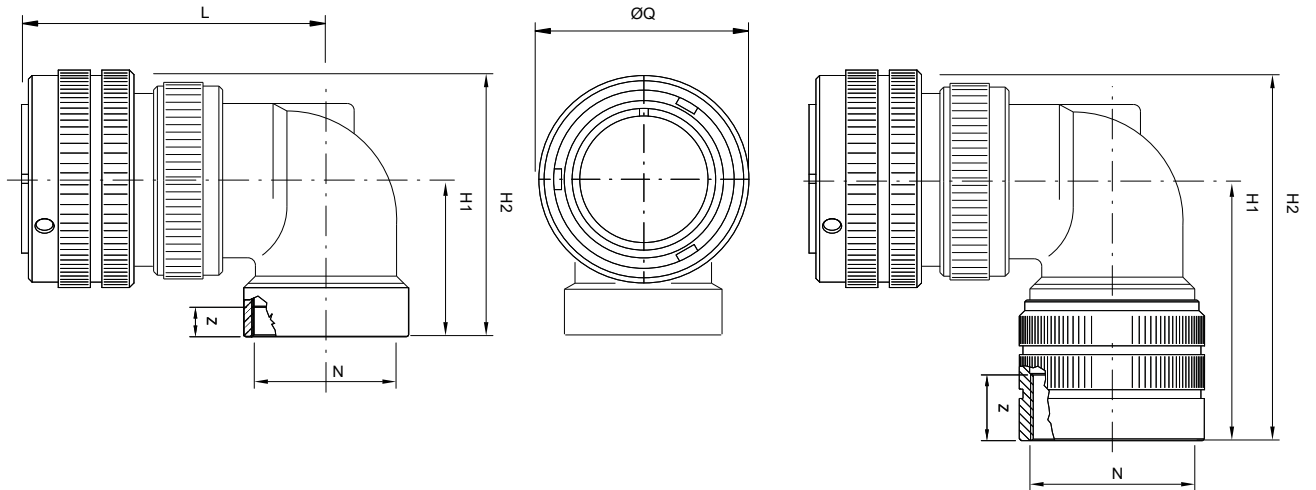

Shell size	ØQ ±0.2	L max	Without adapter				With adapter					
			Z min	H1 max	H2 max	N	Z min	H1 max	H2 max	N		
			Backshell Thread		Thread		Thread		Thread			
			Metric	PG	Metric	PG	Metric	PG	Metric	PG	Metric	PG
10SL	23.3	45.5	7	26	40.3	M16	PG9	12	56	68	M12-M20	PG7-PG11-PG16
14S	29.5	45.5	7	26	40.3	M16	PG9	12	56	70.3	M12-M20	PG7-PG11-PG16
16S	33	47	-	-	-	-	-	6.5	58	73.9	M16	PG11-PG13,5-PG16
16	33	56.5	-	-	-	-	-	6.5	58	73.9	M16	PG11-PG13,5-PG16
18	37	57.5	7	31	48.1	M20	PG16	12	60	75.2	M25	PG13.5-PG21
20	41	60	7	33	51.7	M25	-	12	62	80.7	M16-M20-M32	PG13.5-PG16-PG21-PG29
22	43	62.5	7	35	55.3	M25	PG21	12	65	85.3	M16-M20-M32	PG13.5-PG16-PG29
24	48	65.5	7	38	59.8	M32	PG21	15	69	90.8	M20-M25-M40	PG13.5-PG16-PG29
28	53	65.5	7	40	65	M32	PG21	15	72	97	M20-M25-M40	PG29-PG36
32	60	70	-	-	-	-	-	15	78	106.1	M25-M32-M40	PG21-PG29-PG36
36	66.2	73.5	-	-	-	-	-	15	81	112.3	M32-M40	PG21-PG29-PG36
40	72.4	78.5	-	-	-	-	-	15	85	119.6	M32-M40-M50	PG29-PG36-PG42

Dimensions in mm

Dimension "L" can be different from the value indicated according to backshells accessories, wires size and some special insert configurations.

CVBS - Bayonet Connector with protected mating ramps



Series Code

Shell Type

Connector Class

Backshell internal thread

Shell finish

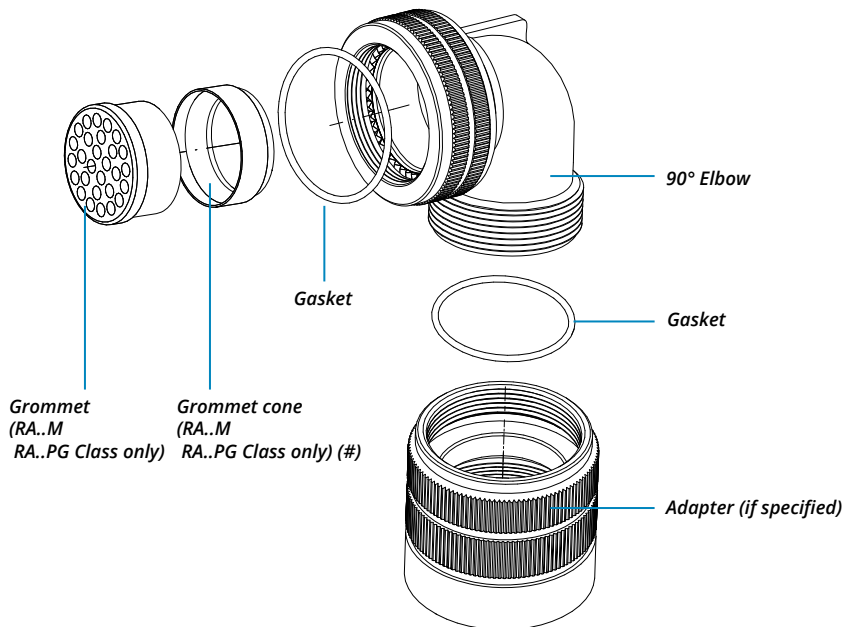

RF	Insulating material	-	Chloroprene rubber
		V	Fluoride rubber
		S	Silicone rubber
		RF	Fire resistant rubber
CVBS	Series Code	CVBS	Bayonet Connector with protected mating ramps
	Shell Material	-	Aluminum
08	Shell Type	08	Plug Connector with 90° elbow
DA	Connector Class	DA	with waterproof O-ring (IP67***)
		RA	with waterproof O-ring and grommet (IP67***) (#)
T	Connector Modification**	T	With plastic caps
20-27	Insert Arrangement		Size - Type
S	Contact Gender	S	Socket contacts
		P	Pin contacts

X	Polarization Code**	Alternate Positions	
M12	Backshell internal thread	M	Provided with an internal Metric thread
		PG	Provided with an internal PG thread
CR	Contact Termination	-	Solder contacts
		CR	Crimp contacts
		LC	Less contacts
CD5	Contact Plating	-	Silver plating
		CD5	Gold plating
		F5	Electroless nickel (*)
F7	Shell finish	F7	Black epoxy varnish (*)
		F16	CCF - Black passivation (*) - conductive
		N	Consult our sales office
N	Modification Code**	N	
		S	

*** Protection degree: IP 67 (only in the mating area with mated connectors) according to EN 60529 (*) RoHS compliance (***) If required (#) In some sizes the grommet cone is not needed

P/N Sample: RF CVBS 08DAT 20-27SX M12 CR CD5 F7 N

CVBS - Bayonet Connector with protected mating ramps

Plug Connector (98) with 90° Elbow Class (AC - ACF)

Connector provided with grounding finger to guarantee shielding; with 90° elbow provided with MS3057...C type Cable-Clamp (for jacketed cable)

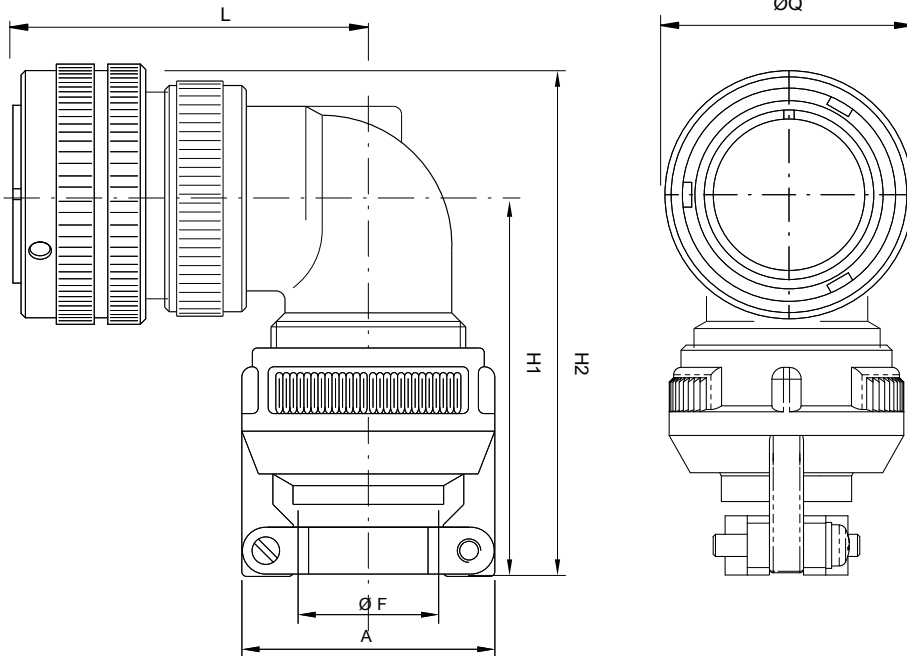
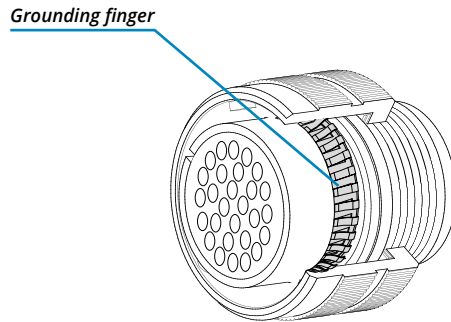

Shell size	ØQ ±0.2	L max	H1 max	H2 max	A max	ØF max cable dimension
------------	------------	----------	-----------	-----------	----------	---------------------------

						Min	Max
10SL	23.3	45.5	51	62.7	23	2.4	7.9
14S	29.5	45.5	51	65.3	26	5.8	11.2
16S	33	47	54	69.9	28.5	8	13.5
16	33	56.5	54	69.9	28.5	8	13.5
18	37	57.5	58.5	75.6	32	9.6	15.9
20	41	60	59.5	78.2	37.5	11.3	19
22	43	62.5	61.5	81.8	37.5	11.3	19
24	48	65.5	71.5	93.3	43.5	15.5	23.8
28	53	65.5	73.5	98.5	43.5	15.5	23.8
32	60	70	84	112.1	54	23.4	31.8
36	66.2	73.5	91.5	122.8	58	25.4	35
40	72.4	78.5	98	132.6	63.5	30	41.3

Dimensions in mm

Dimension "L" can be different from the value indicated according to backshells accessories, wires size and some special insert configurations.

CVBS - Bayonet Connector with protected mating ramps

RF	CVBS		98	ACF	T	20-27	S	X		CR	CD5	F16		N
Series Code	Series Code	Shell Type	Shell Type	Connector Class	Connector Class	Insert Arrangement	Contact Gender	Polarization Code**	Contact Termination	Contact Plating	Contact Plating	Shell finish	Shell finish	Modification Code**

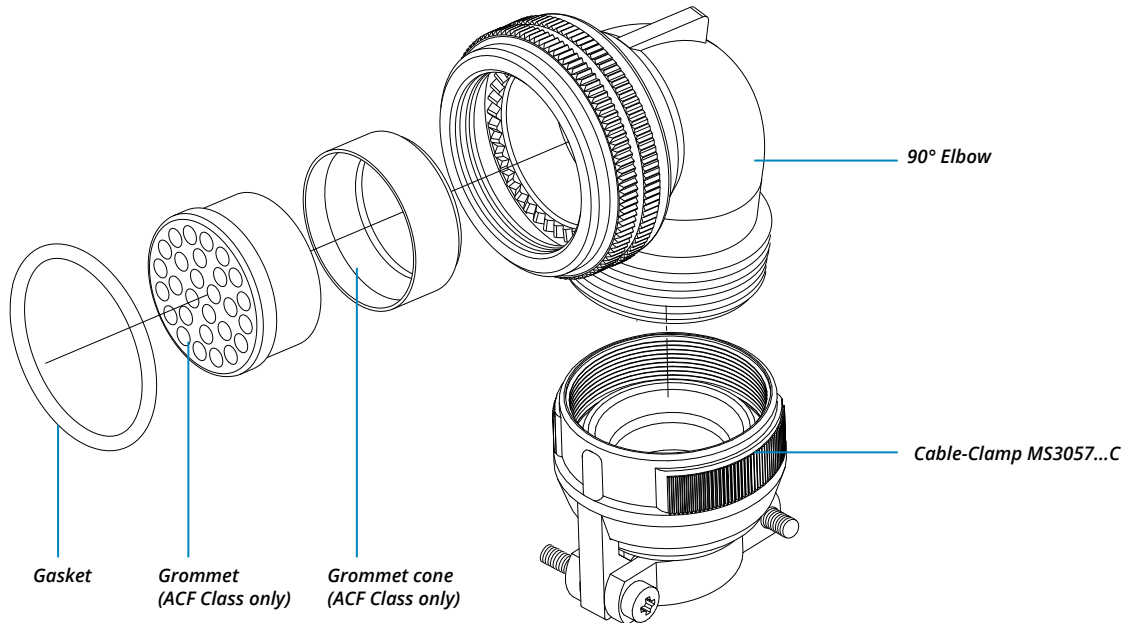

RF	Insulating material	-	Chloroprene rubber
		V	Fluoride rubber
		S	Silicone rubber
		RF	Fire resistant rubber
CVBS	Series Code	CVBS	Bayonet Connector with protected mating ramps
	Shell Material	-	Aluminum
98	Shell Type	98	Plug Connector with grounding finger with 90° elbow
ACF	Connector Class	AC	with waterproof O-ring (IP67)
		ACF	with waterproof O-ring and grommet (IP67) (#)
T	Connector Modification**	T	With plastic caps

20-27	Insert Arrangement		Size - Type
S	Contact Gender	S	Socket contacts
		P	Pin contacts
X	Polarization Code**		Alternate Positions
CR	Contact Termination	-	Solder contacts
		CR	Crimp contacts
		LC	Less contacts
CD5	Contact Plating	-	Silver plating
		CD5	Gold plating
F16	Shell finish	F16	CCF - Black passivation (*) - conductive
N	Modification Code**	N	Consult our sales office
		S	

(#) In some sizes the grommet cone is not needed

(*) RoHS compliance

(**) If required

P/N Sample: RF CVBS 98ACFT 20-27SX CR CD5 F16 N

CVBS - Bayonet Connector with protected mating ramps

Plug Connector (98) with 90° Elbow Class (DA...M - RA...M - DA...PG - RA...PG)

Connector provided with grounding finger to guarantee shielding;
with 90° elbow provided with an internal Metric or PG thread suitable for Cable Glands or conduit adapters.

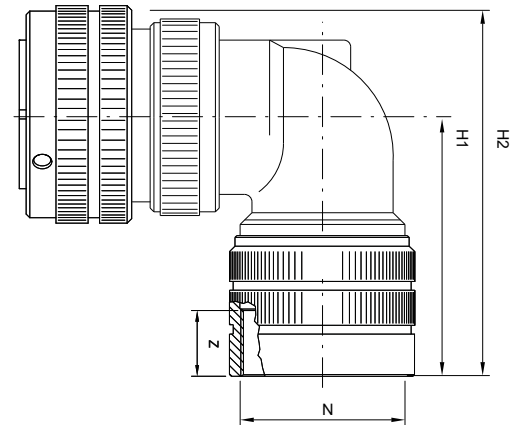
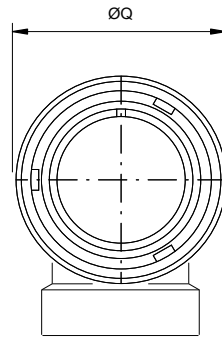
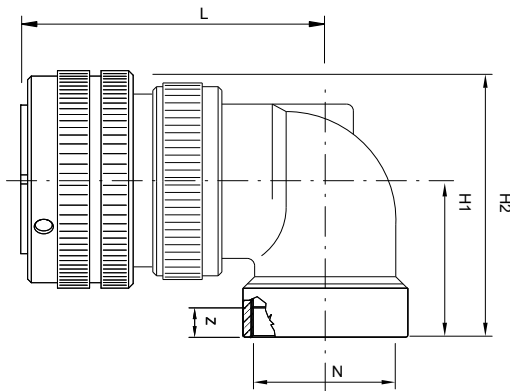
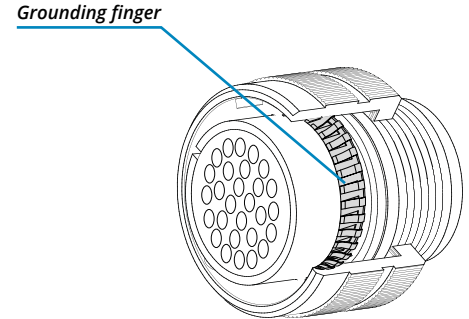

Shell size	ØQ ±0.2	L max	Without adapter					With adapter				
			Z min	H1 max	H2 max	N	Z min	H1 max	H2 max	N		
			Backshell Thread		Metric		PG	Backshell Thread		Metric		PG
10SL	23.3	45.5	7	26	40.3	M16	PG9	12	56	68	M12-M20	PG7-PG11-PG16
14S	29.5	45.5	7	26	40.3	M16	PG9	12	56	70.3	M12-M20	PG7-PG11-PG16
16S	33	47	-	-	-	-	-	6.5	58	73.9	M16	PG11-PG13,5-PG16
16	33	56.5	-	-	-	-	-	6.5	58	73.9	M16	PG11-PG13,5-PG16
18	37	57.5	7	31	48.1	M20	PG16	12	60	75.2	M25	PG13.5-PG21
20	41	60	7	33	51.7	M25	-	12	62	80.7	M16-M20-M32	PG13.5-PG16-PG21-PG29
22	43	62.5	7	35	55.3	M25	PG21	12	65	85.3	M16-M20-M32	PG13.5-PG16-PG29
24	48	65.5	7	38	59.8	M32	PG21	15	69	90.8	M20-M25-M40	PG13.5-PG16-PG29
28	53	65.5	7	40	65	M32	PG21	15	72	97	M20-M25-M40	PG29-PG36
32	60	70	-	-	-	-	-	15	78	106.1	M25-M32-M40	PG21-PG29-PG36
36	66.2	73.5	-	-	-	-	-	15	81	112.3	M32-M40	PG21-PG29-PG36
40	72.4	78.5	-	-	-	-	-	15	85	119.6	M32-M40-M50	PG29-PG36-PG42

Dimensions in mm

Dimension "L" can be different from the value indicated according to backshells accessories, wires size and some special insert configurations.

CVBS - Bayonet Connector with protected mating ramps

RF	CVBS		98	DA	T	20-27	S	X	M12	CR	CD5	F16		N
Series Code	Series Code		Shell Type	Connector Class					Backshell internal thread			Shell finish		

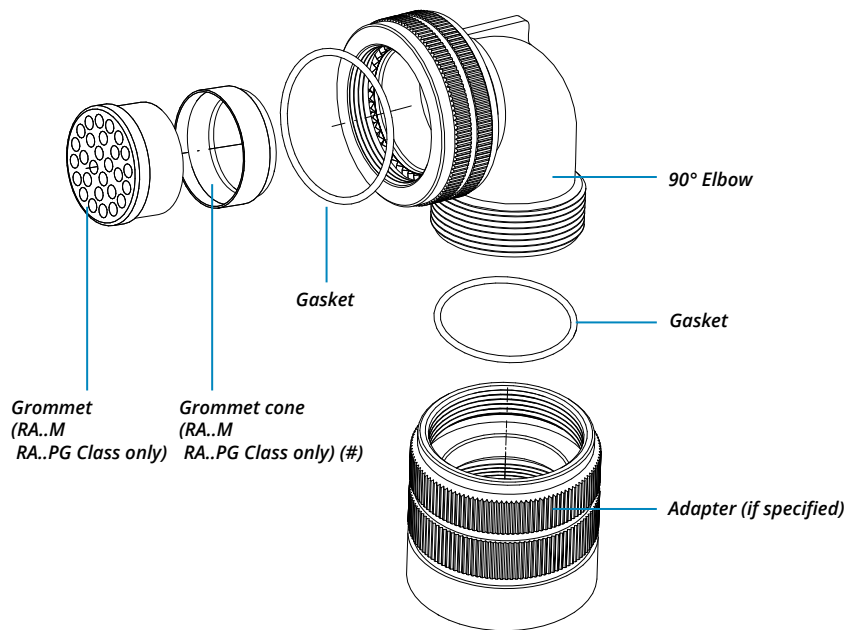

RF	Insulating material	-	Chloroprene rubber	S	Contact Gender	S	Socket contacts
		V	Fluoride rubber			P	Pin contacts
		S	Silicone rubber				
		RF	Fire resistant rubber				
CVBS	Series Code	CVBS	Bayonet Connector with protected mating ramps	X	Polarization Code**		Alternate Positions
	Shell Material	-	Aluminum	M12	Backshell internal thread	M	Provided with an internal Metric thread
						PG	Provided with an internal PG thread
98	Shell Type	98	Plug Connector with grounding finger with 90° elbow	CR	Contact Termination	-	Solder contacts
						CR	Crimp contacts
						LC	Less contacts
DA	Connector Class	DA	with waterproof O-ring (IP67***)	CD5	Contact Plating	-	Silver plating
		RA	with waterproof O-ring and grommet (IP67***) (#)			CD5	Gold plating
T	Connector Modification**	T	With plastic caps	F16	Shell finish	F16	CCF - Black passivation (*) - conductive
20-27	Insert Arrangement		Size - Type	N	Modification Code**	N	Consult our sales office
						S	

*** Protection degree: IP 67 (only in the mating area with mated connectors) according to EN 60529 (*) RoHS compliance (**) If required (#) In some sizes the grommet cone is not needed

P/N Sample: RF CVBS 98DAT 20-27SX M12 CR CD5 F16 N

CVBS - Bayonet Connector with protected mating ramps

Plug Connector with heavy duty coupling nut (65) with Backshell Class (A - DA - RA)

Connector with backshell provided with an external thread suitable for MS3057...A or C type Cable-Clamps (to be ordered separately).

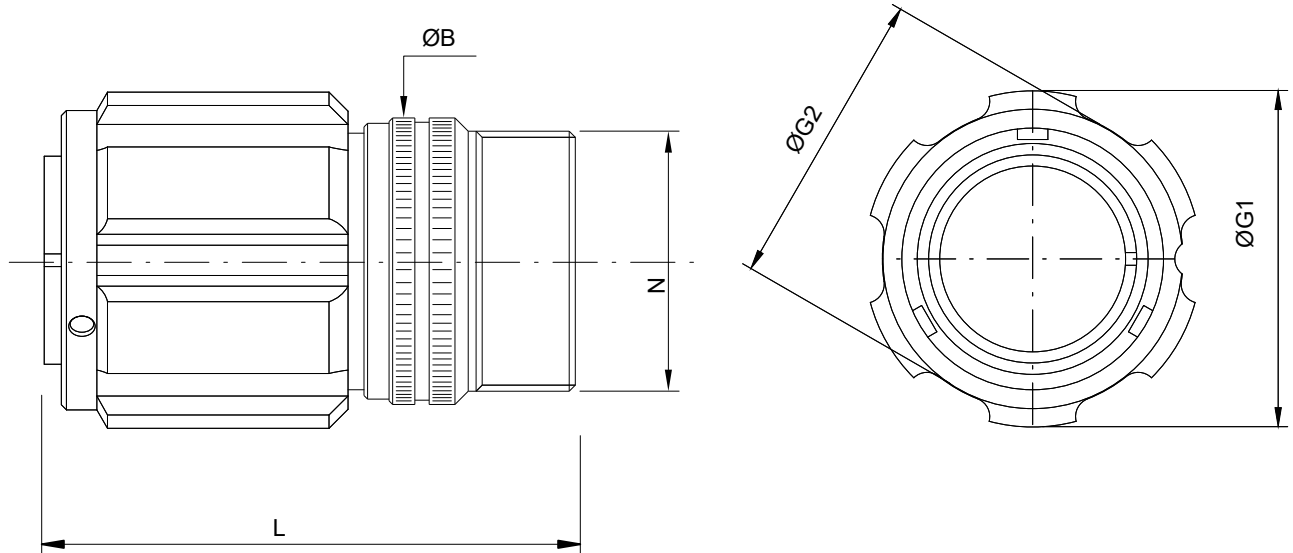

Shell size	ØG1 ±0.5	ØG2 ±0.5	L max	ØB ±0.2	N Backshell Thread in inches
24	53	47.4	55	40	1" 7/16-18 UNEF
28	60.3	54.8	62	45	1" 7/16-18 UNEF
32	67.1	61.8	62	52	1" 3/4-18 UNS
40	79.1	73.6	64	63.8	2" 1/4-16 UN

Dimensions in mm (*) Consult our Sales Office for the availability of this size

Dimension "L" can be different from the value indicated according to backshells accessories, wires size and some special insert configurations.

CVBS - Bayonet Connector with protected mating ramps



Series Code: RF
 Shell Material: CVBS
 Shell Type: 65
 Connector Class: DA
 Connector Modification: T
 Insert Arrangement: 20-27
 Contact Gender: S
 Polarization Code: X
 Contact Termination: CR
 Contact Plating: CD5

Shell finish: F7
 Modification Code: N

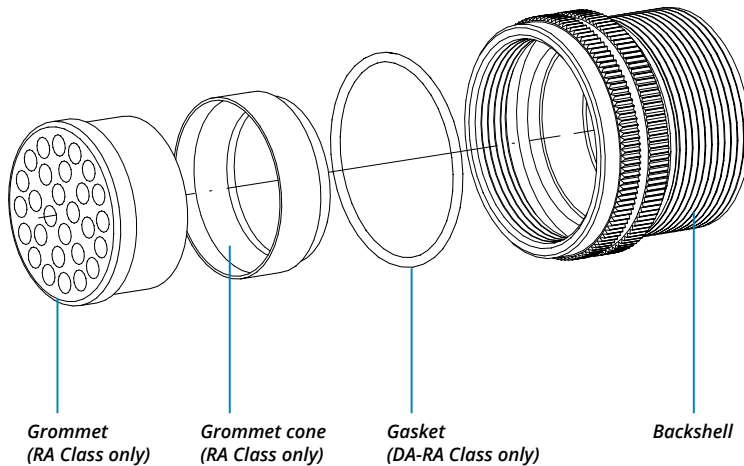

RF	Insulating material	-	Chloroprene rubber
		V	Fluoride rubber
		S	Silicone rubber
		RF	Fire resistant rubber
CVBS	Series Code	CVBS	Bayonet Connector with protected mating ramps
	Shell Material	-	Aluminum
65	Shell Type	65	Plug Connector with heavy duty coupling nut
DA	Connector Class	A	non watertight
		DA	with waterproof O-ring (IP67***)
		RA	with waterproof O-ring and grommet (IP67***)
T	Connector Modification**	T	With plastic caps
20-27	Insert Arrangement		Size - Type

S	Contact Gender	S	Socket contacts
		P	Pin contacts
X	Polarization Code**		Alternate Positions
CR	Contact Termination	-	Solder contacts
		CR	Crimp contacts
		LC	Less contacts
CD5	Contact Plating	-	Silver plating
		CD5	Gold plating
		F5	Electroless nickel (*)
		F7	Black epoxy varnish (*)
F7	Shell finish	F16	CCF - Black passivation (*) - conductive
		F26	hard anodization (*)
		N	
N	Modification Code**	N	
		S	Consult our sales office

*** Protection degree: IP 67 (only in the mating area with mated connectors) according to EN 60529 (*) RoHS compliance (**) If required

P/N Sample: RF CVBS 65DAT 20-27SX CR CD5 F7 N

CVBS - Bayonet Connector with protected mating ramps

Plug Connector with rubber covered coupling nut (06..GG) with Backshell Class (A - DA - RA)

Connector with backshell provided with an external thread suitable for MS3057...A or C type Cable-Clamps (to be ordered separately). Rubber covered coupling nut able to protect against dust and impact.

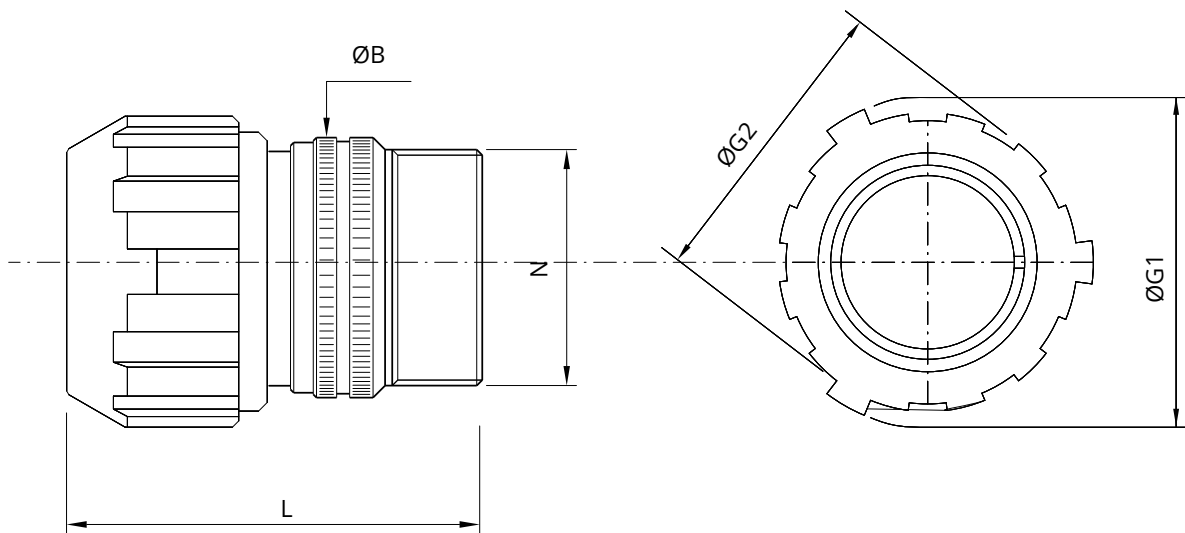

Shell size	ØG1	ØG2	ØB ±0.2	L max	N Backshell Thread in inches
10SL	33.5	28.5	20	38.5	5/8"-24 UNEF
14S	40.2	34.7	24	45.5	3/4"-20 UNEF
16S	44.4	41.35	27	47.2	7/8"-20 UNEF
16	-	-	-	-	-
18	49	43.5	30	56	1"-20 UNEF
20	51.5	46	32	56.5	1" 3/16-18 UNEF
22	56	50.5	37	59	1" 3/16-18 UNEF
24	60	54	40	59	1" 7/16-18 UNEF
28	67	61	45	66	1" 7/16-18 UNEF
32	76	69	52	66	1" 3/4-18 UNS
36	82	73.5	58	66	2"-18 UNS
40	88	80	63.8	68	2"1/4-16 UN

Dimensions in mm

Dimension "L" can be different from the value indicated according to backshells accessories, wires size and some special insert configurations.

CVBS - Bayonet Connector with protected mating ramps

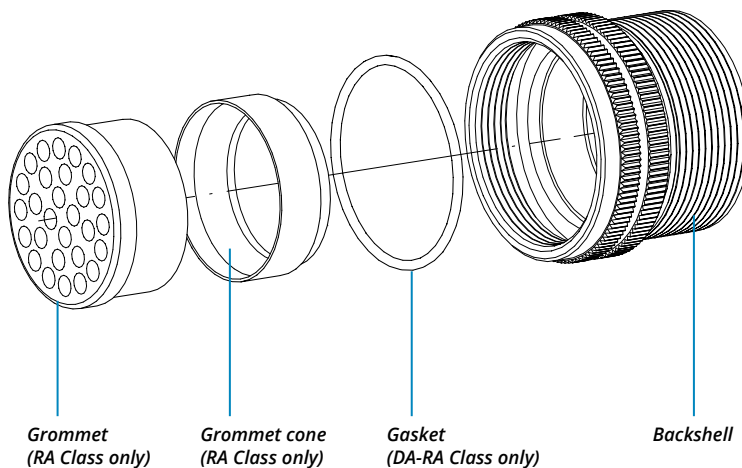

RF	Insulating material	-	Chloroprene rubber
		V	Fluoride rubber
		S	Silicone rubber
		RF	Fire resistant rubber
CVBS	Series Code	CVBS	Bayonet Connector with protected mating ramps
	Shell Material	-	Aluminum
06	Shell Type	06	Plug Connector
DA	Connector Class	A	non watertight
		DA	with waterproof O-ring (IP67***)
GG	Coupling Nut Type	RA	with waterproof O-ring and grommet (IP67***)
		GG	Rubber Covered
T	Connector Modification**	T	With plastic caps

20-27	Insert Arrangement		Size - Type
S	Contact Gender	S	Socket contacts
		P	Pin contacts
X	Polarization Code**		Alternate Positions
CR	Contact Termination	-	Solder contacts
		CR	Crimp contacts
		LC	Less contacts
CD5	Contact Plating	-	Silver plating
		CD5	Gold plating
		F5	Electroless nickel (*)
F7	Shell finish	F7	Black epoxy varnish (*)
		F16	CCF - Black passivation (*) - conductive
		F26	hard anodization (*)
N	Modification Code**	N	Consult our sales office
		S	

*** Protection degree: IP 67 (only in the mating area with mated connectors) according to EN 60529 (*) RoHS compliance (***) If required

P/N Sample: RF CVBS 06DAGGT 20-27SX CR CD5 F7 N

CVBS - Bayonet Connector with protected mating ramps

Plug Connector with rubber covered coupling nut (06..GG) with Backshell Class (AC - ACF)

Connector provided with backshell, MS3057...C type Cable-Clamp. (for jacketed cable)
 Rubber covered coupling nut able to protect against dust and impact.

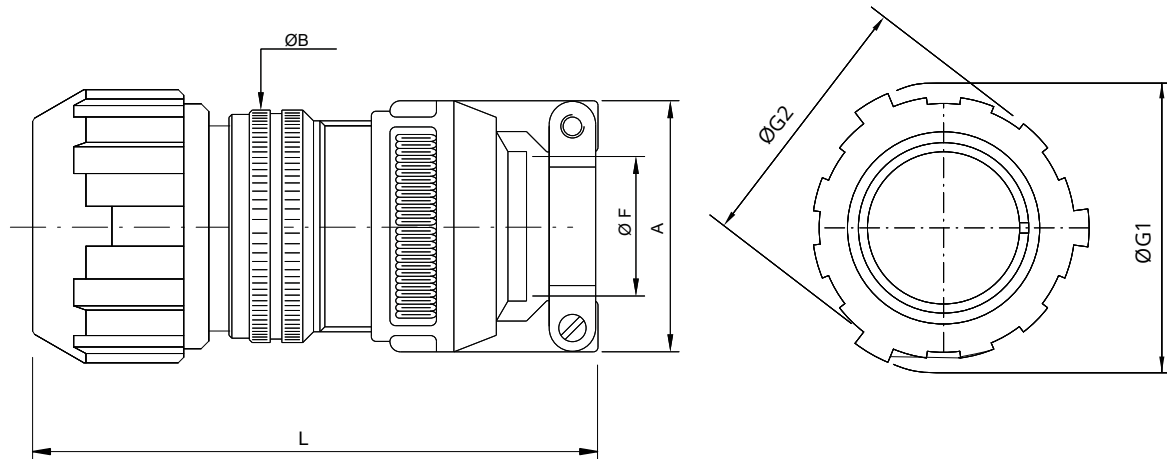

Shell size	ØG1	ØG2	L max	ØB ±0.2	A max	ØF cable dimension	
						Min	Max
10SL	33.5	28.5	62.5	20	23	2.4	7.9
14S	40.2	34.7	69.5	24	26	5.8	11.2
16S	44.4	41.35	72.2	27	28.5	8	13.5
16	-	-	-	-	-	-	-
18	49	43.5	83.5	30	32	9.6	15.9
20	51.5	46	83.5	32	37.5	11.3	19
22	56	50.5	85.5	37	37.5	11.3	19
24	60	54	92.5	40	43.5	15.5	23.8
28	67	61	99.5	45	43.5	15.5	23.8
32	76	69	104	52	54	23.4	31.8
36	82	73.5	108.5	58	58	25.4	35
40	88	80	112	63.2	63.5	30	41.3

Dimensions in mm

Dimension "L" can be different from the value indicated according to backshells accessories, wires size and some special insert configurations.

CVBS - Bayonet Connector with protected mating ramps

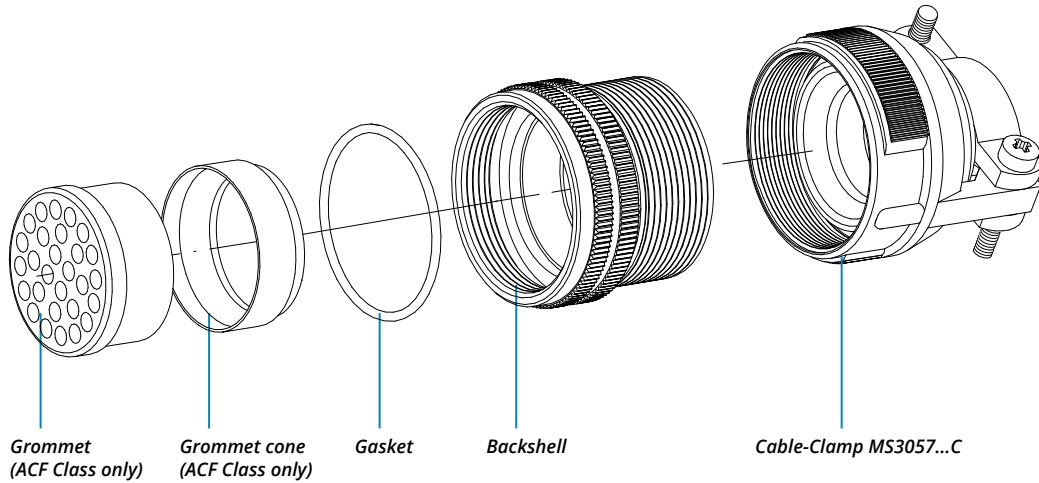

RF	Insulating material	-	Chloroprene rubber
		V	Fluoride rubber
		S	Silicone rubber
		RF	Fire resistant rubber
CVBS	Series Code	CVBS	Bayonet Connector with protected mating ramps
	Shell Material	-	Aluminum
06	Shell Type	06	Plug Connector
ACF	Connector Class	AC	with waterproof O-ring (IP67)
		ACF	with waterproof O-ring and grommet (IP67)
GG	Coupling Nut Type	GG	Rubber Covered
T	Connector Modification**	T	With plastic caps
20-27	Insert Arrangement		Size - Type

S	Contact Gender	S	Socket contacts
		P	Pin contacts
X	Polarization Code**		Alternate Positions
CR	Contact Termination	-	Solder contacts
		CR	Crimp contacts
		LC	Less contacts
CD5	Contact Plating	-	Silver plating
		CD5	Gold plating
F7	Shell finish	F5	Electroless nickel (*)
		F7	Black epoxy varnish (*)
		F16	CCF - Black passivation (*) - conductive
		F26	hard anodization (*)
N	Modification Code**	N	Consult our sales office
		S	

P/N Sample: RF CVBS 06ACFGGT 20-27SX CR CD5 F7 N

(*) RoHS compliance

(**) If required

CVBS - Bayonet Connector with protected mating ramps

Plug Connector with rubber covered coupling nut (06..GG) with Backshell Class (DA..M - RA..M DA..PG - RA..PG)

Connector with backshell provided with an internal Metric or PG thread suitable for Cable Glands or conduit adapters. Rubber covered coupling nut able to protect against dust and impact.

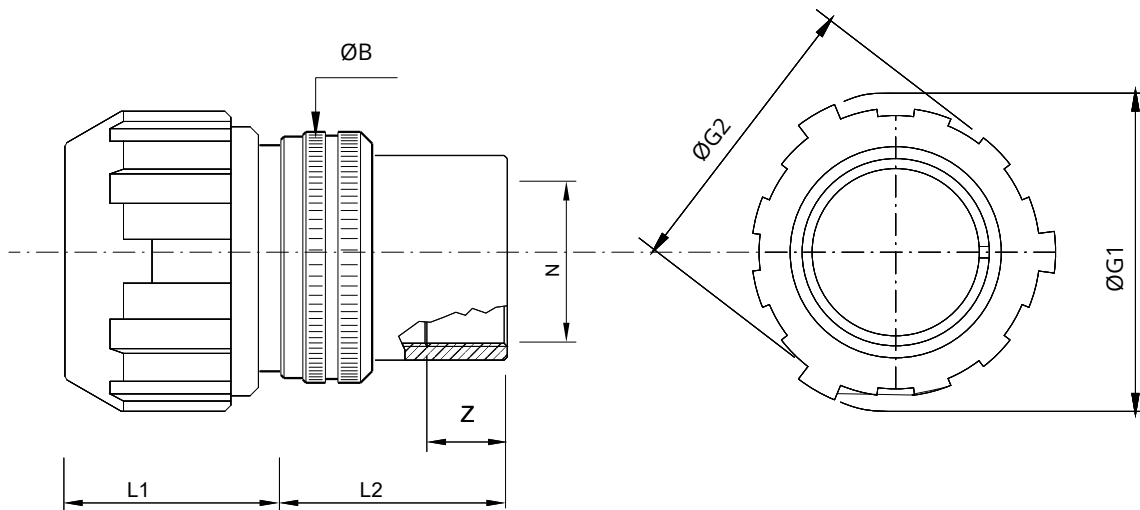

Shell size	ØG1	ØG2	ØB ±0.2	Z min	L1	N Backshell Metric thread	L2 M	N Backshell PG Thread	L2 PG
10SL	33.5	28.5	20	8	22	M12 - M16	32	(PG9) - PG13.5	26
14S	40.2	34.7	24	9	23	M12 - M16 - (M20) - (M25)	30	(PG9) - PG11 - PG13.5 - (PG16)	30
16S	44.4	41.35	27	9	24	(M16) - M20	40	PG13.5 - (PG16)	38
16	-	-	-	-	-	-	-	-	-
18	49	43.5	30	9	29	M20 - M25	50	(PG11) - (PG13.5) - PG16 - PG21	50
20	51.5	46	32	9	29	M16 - M20 - M25 - (M32)	50	PG11-PG13.5-PG16-PG21-PG29	50
22	56	50.5	37	10	30	M16 - M20 - M25 - M32	50	PG13.5 - (PG16) - (PG29)	50
24	60	54	40	10	30	M20 - M25 - M32 - M40	50	PG16 - PG21 - PG29	50
28	67	61	45	10	30	(M25) - M32 - M40	63	PG21 - PG29 - PG36	60
32	76	69	52	10	32	(M25) - (M32) - M40	55	PG21 - (PG29) - PG36	60
36	82	73.5	58	13	32	M40 - M50	56	PG29 - (PG36) - (PG42)	65
40	88	80	63.8	13	33	M40 - (M50) - M63	65	PG29 - (PG36) - (PG42) - (PG48)	65

Dimensions in mm

Dimensions "L1 and L2" can be different from the value indicated according to backshells accessories, wires size and some special insert configurations.

(...) The threads in parentheses are versions on request with non standard backshell length (the dimensions L2 and Z are different from this page indication). Please consult our sales office for the specific dimensions.

CVBS - Bayonet Connector with protected mating ramps

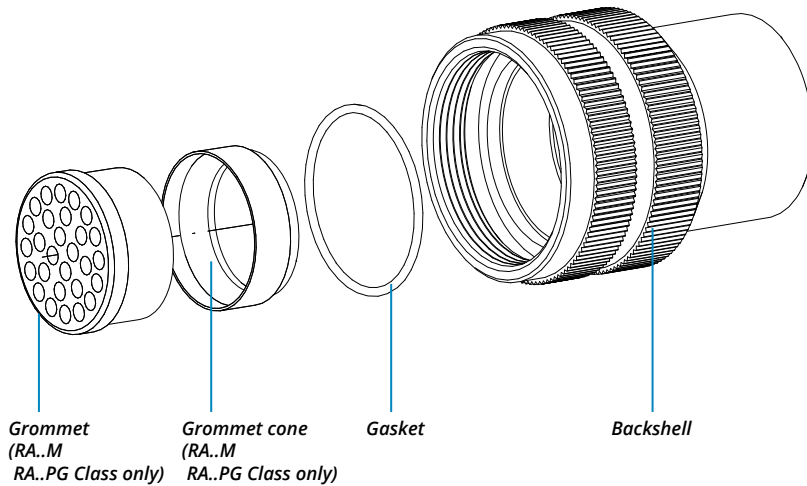

RF	Insulating material	-	Chloroprene rubber
		V	Fluoride rubber
		S	Silicone rubber
		RF	Fire resistant rubber
CVBS	Series Code	CVBS	Bayonet Connector with protected mating ramps
	Shell Material	-	Aluminum
06	Shell Type	06	Plug Connector
DA	Connector Class	DA	with waterproof O-ring (IP67***)
		RA	with waterproof O-ring and grommet (IP67***)
GG	Coupling Nut Type	GG	Rubber Covered
T	Connector Modification**	T	With plastic caps
20-27	Insert Arrangement		Size - Type

S	Contact Gender	S	Socket contacts
		P	Pin contacts
X	Polarization Code**		Alternate Positions
M12	Backshell internal thread	M	Provided with an internal Metric thread
		PG	Provided with an internal PG thread
CR	Contact Termination	-	Solder contacts
		CR	Crimp contacts
		LC	Less contacts
CD5	Contact Plating	-	Silver plating
		CD5	Gold plating
		F5	Electroless nickel (*)
		F7	Black epoxy varnish (*)
F7	Shell finish	F16	CCF - Black passivation (*) - conductive
		F26	hard anodization (*)
		N	Consult our sales office
N	Modification Code**	N	Consult our sales office
		S	Consult our sales office

*** Protection degree: IP 67 (only in the mating area with mated connectors) according to EN 60529 (*) RoHS compliance (**) If required

P/N Sample: RF CVBS 06DAGGT 20-27SX M12 CR CD5 F7 N

CVBS - Bayonet Connector with protected mating ramps

Plug Connector with rubber covered coupling nut (96..GG) with Backshell Class (A - DA - RA)

Connector provided with grounding finger to guarantee shielding; backshell provided with an external thread suitable for MS3057...A or C type Cable-Clamps (to be ordered separately). Rubber covered coupling nut able to protect against dust and impact.

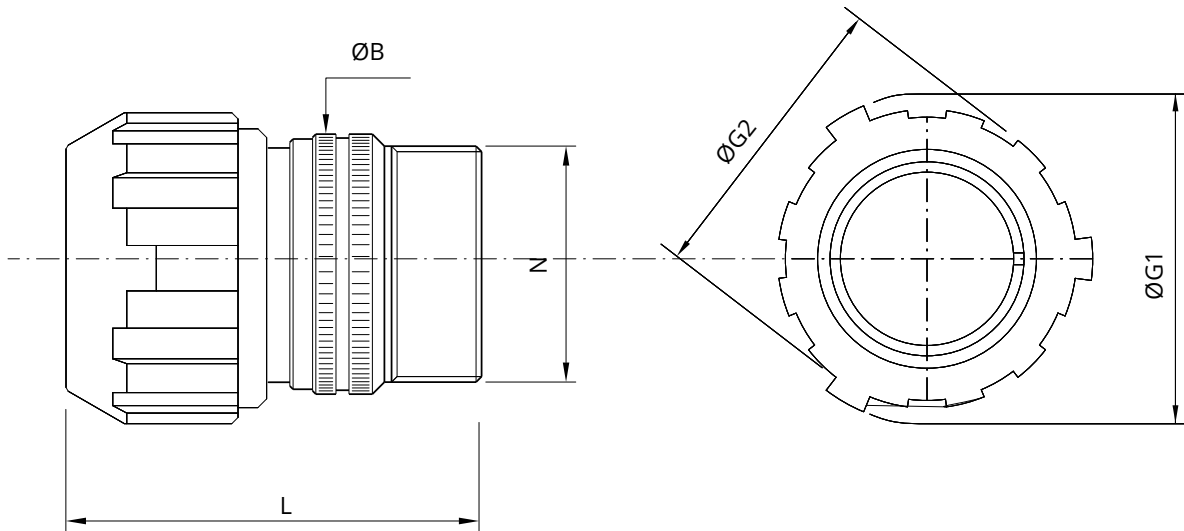
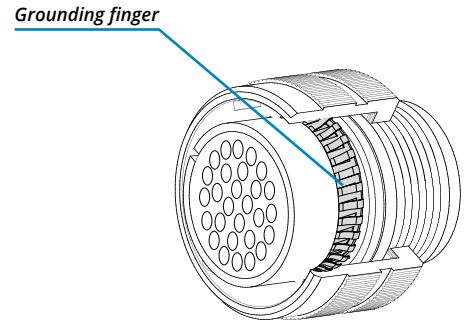

Shell size	ØG1	ØG2	ØB ±0.2	L max	N Backshell Thread in inches
10SL	33.5	28.5	20	38.5	5/8"-24 UNEF
14S	40.2	34.7	24	45.5	3/4"-20 UNEF
16S	44.4	41.35	27	47.2	7/8"-20 UNEF
16	-	-	-	-	-
18	49	43.5	30	56	1"-20 UNEF
20	51.5	46	32	56.5	1" 3/16-18 UNEF
22	56	50.5	37	59	1" 3/16-18 UNEF
24	60	54	40	59	1" 7/16-18 UNEF
28	67	61	45	66	1" 7/16-18 UNEF
32	76	69	52	66	1" 3/4-18 UNS
36	82	73.5	58	66	2"-18 UNS
40	88	80	63.8	68	2"1/4-16 UN

Dimensions in mm

Dimension "L" can be different from the value indicated according to backshells accessories, wires size and some special insert configurations.

CVBS - Bayonet Connector with protected mating ramps

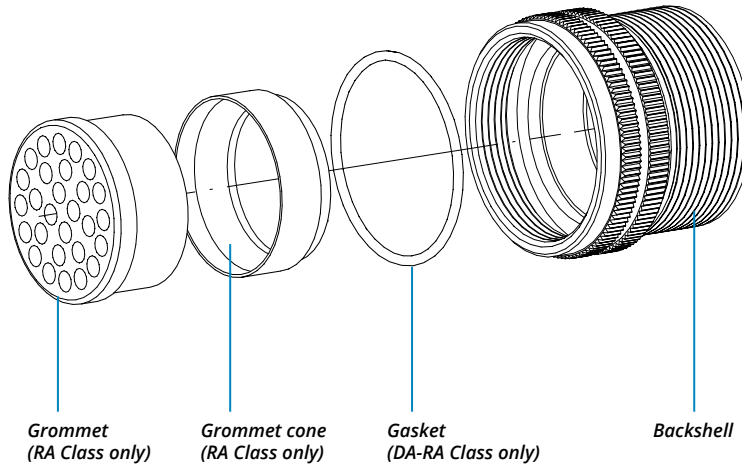

RF	Insulating material	-	Chloroprene rubber
		V	Fluoride rubber
		S	Silicone rubber
		RF	Fire resistant rubber
CVBS	Series Code	CVBS	Bayonet Connector with protected mating ramps
[]	Shell Material	-	Aluminum
96	Shell Type	96	Plug Connector with grounding finger
DA	Connector Class	A	non watertight
		DA	with waterproof O-ring (IP67***)
GG	Coupling Nut Type	RA	with waterproof O-ring and grommet (IP67***)
		GG	Rubber Covered
T	Connector Modification**	T	With plastic caps

20-27	Insert Arrangement		Size - Type
S	Contact Gender	S	Socket contacts
		P	Pin contacts
X	Polarization Code**		Alternate Positions
CR	Contact Termination	-	Solder contacts
		CR	Crimp contacts
		LC	Less contacts
CD5	Contact Plating	-	Silver plating
		CD5	Gold plating
		F5	Electroless nickel (*)
		F7	Black epoxy varnish (*)
F7	Shell finish	F16	CCF - Black passivation (*) - conductive
		F26	hard anodization (*)
		N	Consult our sales office
N	Modification Code**	S	

*** Protection degree: IP 67 (only in the mating area with mated connectors) according to EN 60529 (*) RoHS compliance (**) If required

P/N Sample: RF CVBS 96DAGGT 20-27SX CR CD5 F7 N

CVBS - Bayonet Connector with protected mating ramps

Plug Connector with rubber covered coupling nut (08..GG) with 90° Elbow Class (A - DA - RA)

Connector with 90° elbow provided with an external thread suitable for MS3057...A or C type Cable-Clamps (to be ordered separately). Rubber covered coupling nut able to protect against dust and impact.

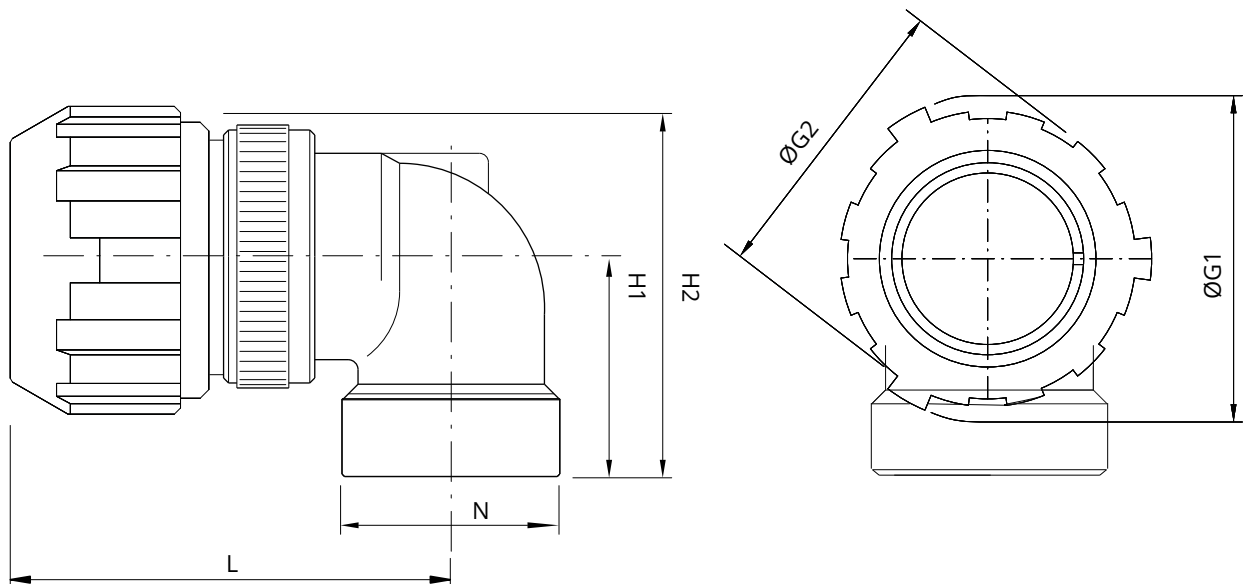

Shell size	ØG1	ØG2	L max	H1 max	H2 max	N Backshell Thread in inches
10SL	33.5	28.5	48	27	43.8	5/8"-24 UNEF
14S	40.2	34.7	48	27	47.1	3/4"-20 UNEF
16S	44.4	41.35	51.2	29	51.2	7/8"-20 UNEF
16	-	-	-	-	-	-
18	49	43.5	61.5	31	55.5	1"-20 UNEF
20	51.5	46	63.5	33	58.8	1" 3/16-18 UNEF
22	56	50.5	65.5	35	63	1" 3/16-18 UNEF
24	60	54	69	38	68	1" 7/16-18 UNEF
28	67	61	69	40	73.5	1" 7/16-18 UNEF
32	76	69	74	46	84	1" 3/4-18 UNS
36	82	73.5	77.5	49	90	2"-18 UNS
40	88	80	82.5	53	97	2" 1/4-16 UN

Dimensions in mm

Dimension "L" can be different from the value indicated according to backshells accessories, wires size and some special insert configurations.

CVBS - Bayonet Connector with protected mating ramps

RF	CVBS		08	DA	GG	T	20-27	S	X		CR	CD5	F7		N
Series Code		Shell Type		Connector Class								Shell finish			

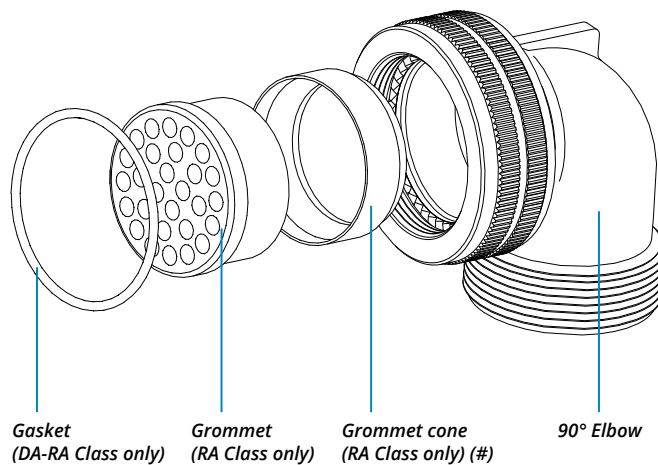

RF	Insulating material	-	Chloroprene rubber
		V	Fluoride rubber
		S	Silicone rubber
		RF	Fire resistant rubber
CVBS	Series Code	CVBS	Bayonet Connector with protected mating ramps
	Shell Material	-	Aluminum
08	Shell Type	08	Plug Connector with 90° elbow
DA	Connector Class	A	non watertight
		DA	with waterproof O-ring (IP67***)
		RA	with waterproof O-ring and grommet (IP67***) (#)
GG	Coupling Nut Type	GG	Rubber Covered
T	Connector Modification**	T	With plastic caps

20-27	Insert Arrangement		Size - Type
S	Contact Gender	S	Socket contacts
		P	Pin contacts
X	Polarization Code**		Alternate Positions
CR	Contact Termination	-	Solder contacts
		CR	Crimp contacts
		LC	Less contacts
CD5	Contact Plating	-	Silver plating
		CD5	Gold plating
F7	Shell finish	F5	Electroless nickel (*)
		F7	Black epoxy varnish (*)
		F16	CCF - Black passivation (*) - conductive
N	Modification Code**	N	Consult our sales office
		S	

*** Protection degree: IP 67 (only in the mating area with mated connectors) according to EN 60529 (*) RoHS compliance (**) If required

P/N Sample: RF CVBS 08DAGGT 20-27SX CR CD5 F7 N

(#) In some sizes the grommet cone is not needed

CVBS - Bayonet Connector with protected mating ramps

Plug Connector with rubber covered coupling nut (08..GG) with 90° Elbow Class (AC - ACF)

Connector with 90° elbow provided with MS3057...C type Cable-Clamp (for jacketed cable)
 Rubber covered coupling nut able to protect against dust and impact.

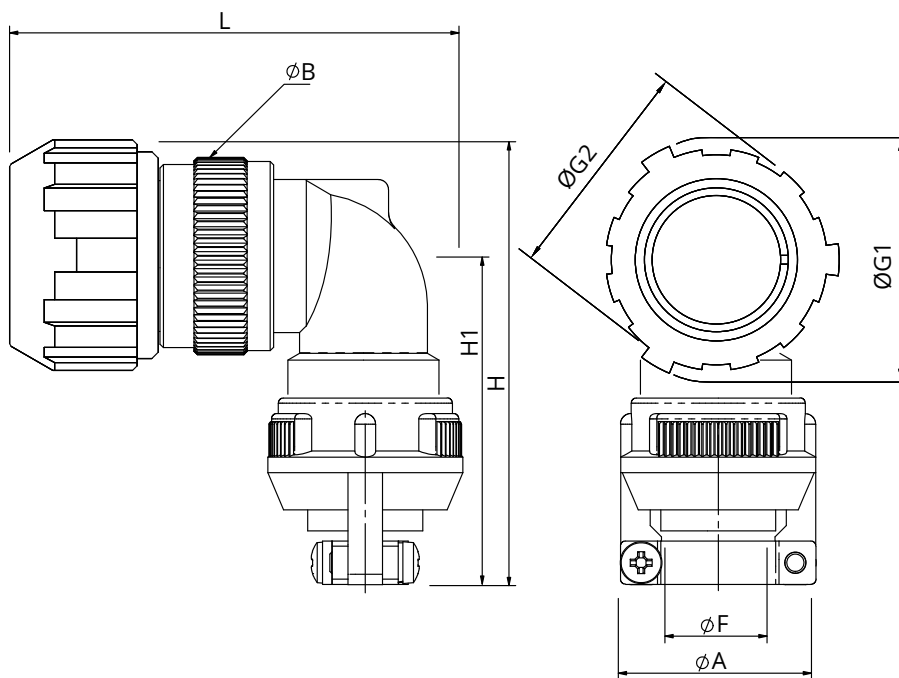

Shell size	ØG1	ØG2	L max	H1 max	H max	ØB max	A max	ØF max cable dimension	
								Min	Max
10SL	33.5	28.5	58.5	51	67.8	20	23	2.4	7.9
14S	40.2	34.7	58.5	51	75.1	24	26	5.8	11.2
16S	44.4	41.35	51.2	54	76.2	27	28.5	8	13.5
16	-	-	-	-	-	-	-	-	-
18	49	43.5	73.5	58.5	86.5	30	32	9.6	15.9
20	51.5	46	78.8	59.5	90.8	32	37.5	11.3	19
22	56	50.5	81.3	61.5	95	37	37.5	11.3	19
24	60	54	87.3	71.5	103	40	43.5	15.5	23.8
28	67	61	87.3	73.5	108.5	45	43.5	15.5	23.8
32	76	69	97	84	123	52	54	23.4	31.8
36	82	73.5	102.5	91.5	136	58	58	25.4	35
40	88	80	110.3	98	142	63.2	63.5	30	41.3

Dimensions in mm

Dimension "L" can be different from the value indicated according to backshells accessories, wires size and some special insert configurations.

CVBS - Bayonet Connector with protected mating ramps

RF	CVBS		08	ACF	GG	T	20-27	S	X		CR	CD5	F7		N
	Series Code		Shell Type	Connector Class									Shell finish		

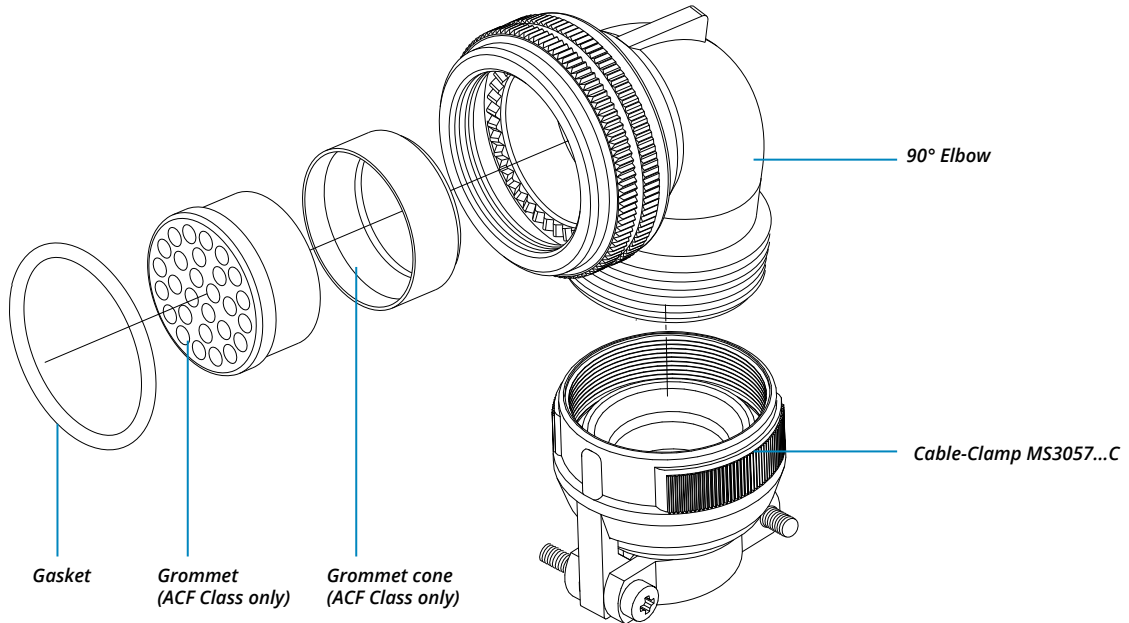

RF	Insulating material	-	Chloroprene rubber
		V	Fluoride rubber
		S	Silicone rubber
		RF	Fire resistant rubber
CVBS	Series Code	CVBS	Bayonet Connector with protected mating ramps
	Shell Material	-	Aluminum
08	Shell Type	08	Plug Connector with 90° elbow
ACF	Connector Class	AC	with waterproof O-ring (IP67)
		ACF	with waterproof O-ring and grommet (IP67) (#)
GG	Coupling Nut Type	GG	Rubber Covered
T	Connector Modification**	T	With plastic caps

20-27	Insert Arrangement		Size - Type
S	Contact Gender	S	Socket contacts
		P	Pin contacts
X	Polarization Code**		Alternate Positions
CR	Contact Termination	-	Solder contacts
		CR	Crimp contacts
		LC	Less contacts
CD5	Contact Plating	-	Silver plating
		CD5	Gold plating
F7	Shell finish	F5	Electroless nickel (*)
		F7	Black epoxy varnish (*)
		F16	CCF - Black passivation (*) - conductive
N	Modification Code**	N	Consult our sales office
		S	

(#) In some sizes the grommet cone is not needed

(*) RoHS compliance

(**) If required

P/N Sample: RF CVBS 08ACFGGT 20-27SX CR CD5 F7 N

CVBS - Bayonet Connector with protected mating ramps

Plug Connector with rubber covered coupling nut (98..GG) with 90° Elbow Class (A - DA - RA)

Connector with 90° elbow provided with an external thread suitable for MS3057...A or C type Cable-Clamps (to be ordered separately).
 Connector provided with grounding finger to guarantee shielding;
 Rubber covered coupling nut able to protect against dust and impact.

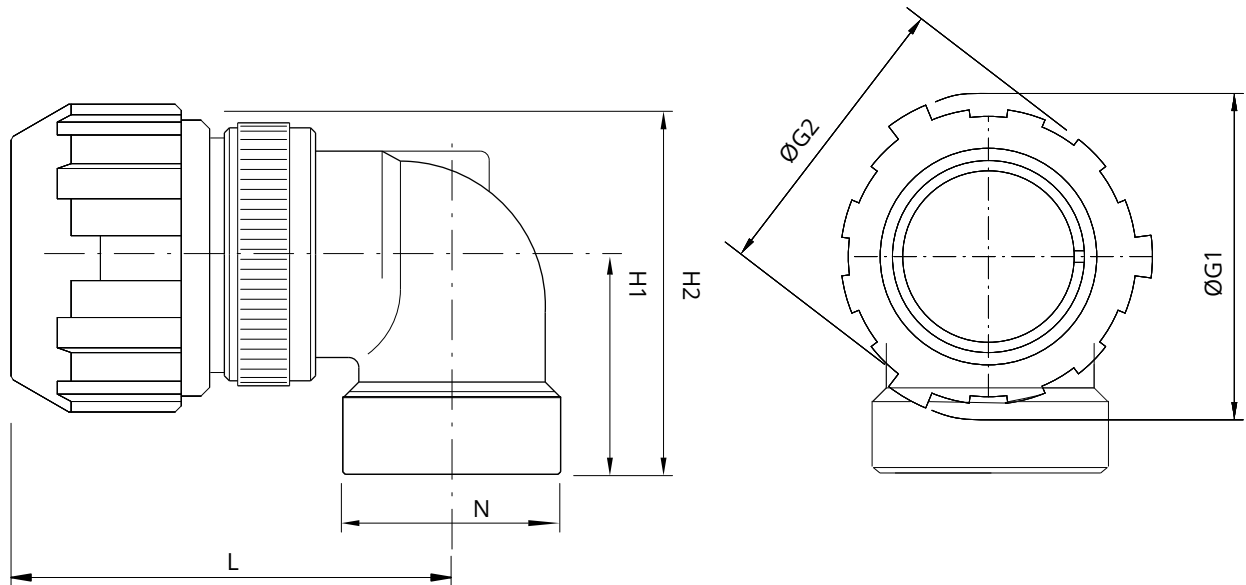
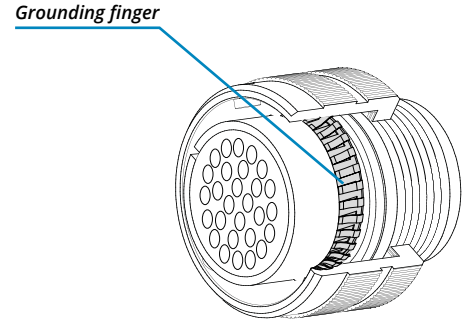

Shell size	ØG1	ØG2	L max	H1 max	H2 max	N Backshell Thread in inches
10SL	33.5	28.5	48	27	43.8	5/8"-24 UNEF
14S	40.2	34.7	48	27	47.1	3/4"-20 UNEF
16S	44.4	41.35	51.2	29	51.2	7/8"-20 UNEF
16	-	-	-	-	-	-
18	49	43.5	61.5	31	55.5	1"-20 UNEF
20	51.5	46	63.5	33	58.8	1" 3/16-18 UNEF
22	56	50.5	65.5	35	63	1" 3/16-18 UNEF
24	60	54	69	38	68	1" 7/16-18 UNEF
28	67	61	69	40	73.5	1" 7/16-18 UNEF
32	76	69	74	46	84	1" 3/4-18 UNS
36	82	73.5	77.5	49	90	2"-18 UNS
40	88	80	82.5	53	97	2" 1/4-16 UN

Dimensions in mm

Dimension "L" can be different from the value indicated according to backshells accessories, wires size and some special insert configurations.

CVBS - Bayonet Connector with protected mating ramps

RF	CVBS		98	DA	GG	T	20-27	S	X		CR	CD5	F7		N
Series Code		Shell Type		Connector Class								Shell finish			

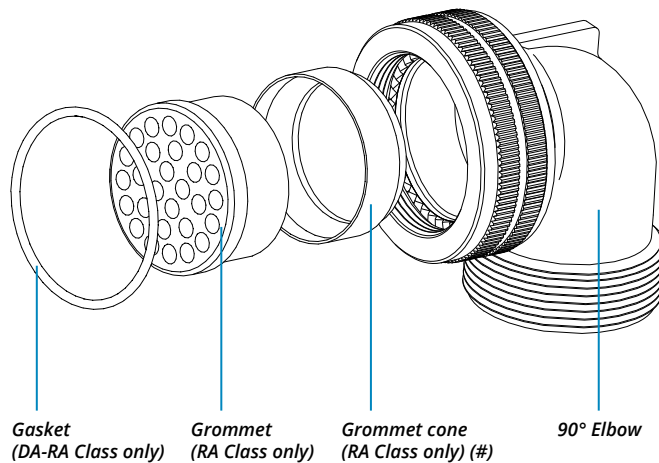

RF	Insulating material	-	Chloroprene rubber
		V	Fluoride rubber
		S	Silicone rubber
		RF	Fire resistant rubber
CVBS	Series Code	CVBS	Bayonet Connector with protected mating ramps
	Shell Material	-	Aluminum
98	Shell Type	98	Plug Connector with grounding finger with 90° elbow
		A	non watertight
DA	Connector Class	DA	with waterproof O-ring (IP67***)
		RA	with waterproof O-ring and grommet (IP67***) (#)
GG	Coupling Nut Type	GG	Rubber Covered
T	Connector Modification**	T	With plastic caps

20-27	Insert Arrangement		Size - Type
S	Contact Gender	S	Socket contacts
		P	Pin contacts
X	Polarization Code**		Alternate Positions
CR	Contact Termination	-	Solder contacts
		CR	Crimp contacts
		LC	Less contacts
CD5	Contact Plating	-	Silver plating
		CD5	Gold plating
F7	Shell finish	F5	Electroless nickel (*)
		F7	Black epoxy varnish (*)
		F16	CCF - Black passivation (*) - conductive
N	Modification Code**	N	Consult our sales office
		S	

*** Protection degree: IP 67 (only in the mating area with mated connectors) according to EN 60529 (*) RoHS compliance (**) If required

P/N Sample: RF CVBS 08DAGGT 20-27SX CR CD5 F7 N

(#) In some sizes the grommet cone is not needed

CVBS - Bayonet Connector with protected mating ramps

Plug Connector with rubber covered coupling nut (short version) (61..GG) with Backshell Class (A - DA - RA)

Connector with backshell provided with an external thread suitable for MS3057...A or C type Cable-Clamps (to be ordered separately). Rubber covered coupling nut (short version) able to protect against dust and impact.

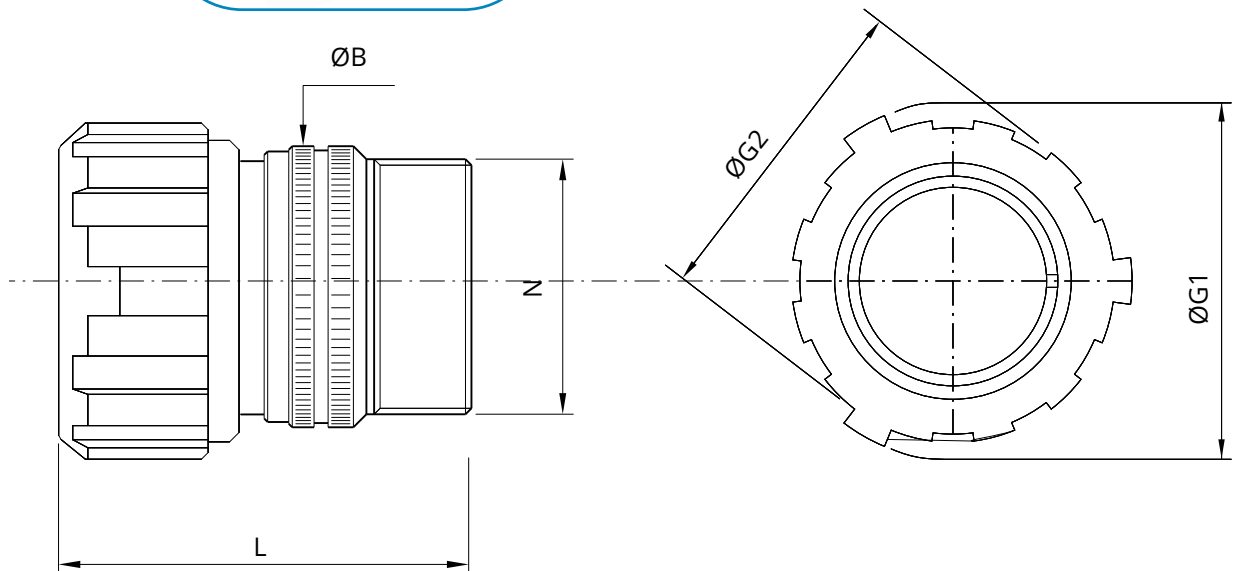

Shell size	ØG1	ØG2	ØB ±0.2	L max	N Backshell Thread in inches
10SL	33.5	28.5	20	38.5	5/8"-24 UNEF
14S	40.2	34.7	24	45.5	3/4"-20 UNEF
16S	44.4	41.35	27	47.2	7/8"-20 UNEF
16	-	-	-	-	-
18	49	43.5	30	56	1"-20 UNEF
20	51.5	46	32	56.5	1" 3/16-18 UNEF
22	56	50.5	37	59	1" 3/16-18 UNEF
24	60	54	40	59	1" 7/16-18 UNEF
28	67	61	45	66	1" 7/16-18 UNEF
32	76	69	52	66	1" 3/4-18 UNS
36	82	73.5	58	66	2"-18 UNS
40	88	80	63.8	68	2"1/4-16 UN

Dimensions in mm

Dimension "L" can be different from the value indicated according to backshells accessories, wires size and some special insert configurations.

CVBS - Bayonet Connector with protected mating ramps

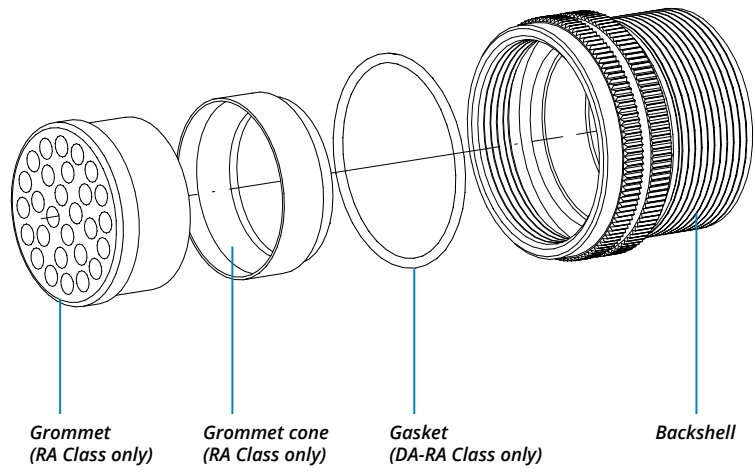

RF	Insulating material	-	Chloroprene rubber	20-27	Insert Arrangement		Size - Type
		V	Fluoride rubber				
		S	Silicone rubber	S	Contact Gender	S	Socket contacts
		RF	Fire resistant rubber			P	Pin contacts
CVBS	Series Code	CVBS	Bayonet Connector with protected mating ramps	X	Polarization Code**		Alternate Positions
[]	Shell Material	-	Aluminum	CR	Contact Termination	-	Solder contacts
61	Shell Type	61	Plug Connector Rubber covered coupling nut (short version)			CR	Crimp contacts
		A	non watertight			LC	Less contacts
DA	Connector Class	DA	with waterproof O-ring (IP67***)	CD5	Contact Plating	-	Silver plating
		RA	with waterproof O-ring and grommet (IP67***)			CD5	Gold plating
GG	Coupling Nut Type	GG	Rubber Covered	F7	Shell finish	F5	Electroless nickel (*)
						F7	Black epoxy varnish (*)
T	Connector Modification**	T	With plastic caps			F16	CCF - Black passivation (*) - conductive
				N	Modification Code**	F26	hard anodization (*)
						N	Consult our sales office
						S	

*** Protection degree: IP 67 (only in the mating area with mated connectors) according to EN 60529 (*) RoHS compliance (***) If required

P/N Sample: RF CVBS 61DAGGT 20-27SX CR CD5 F7 N

CVBS - Bayonet Connector with protected mating ramps

Plug Connector with rubber covered coupling nut (short version) (61..GG) with Backshell Class (AC - ACF)

Connector provided with backshell, MS3057...C type Cable-Clamp. (for jacketed cable)
 Rubber covered coupling nut (short version) able to protect against dust and impact.

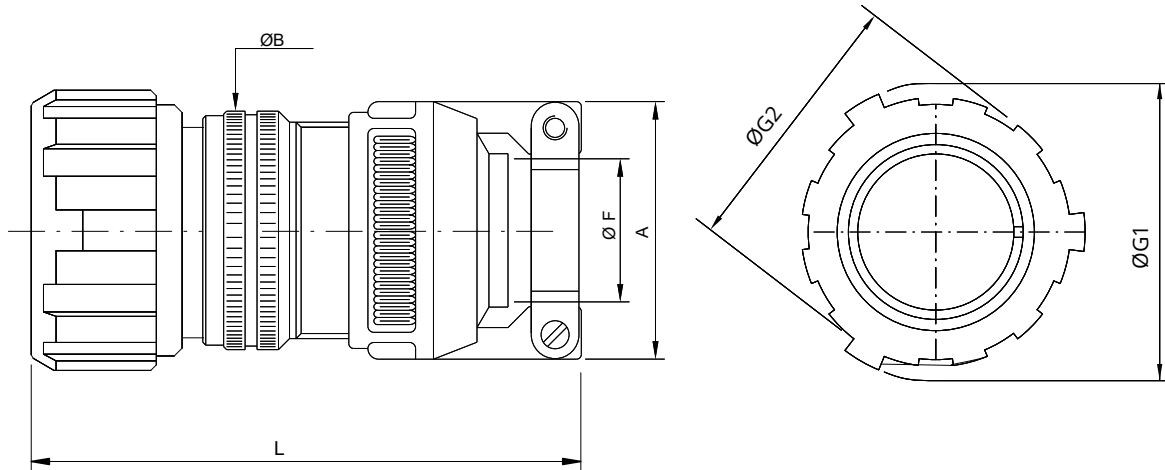

Shell size	ØG1	ØG2	L max	ØB ±0.2	A max	ØF cable dimension	
						Min	Max
10SL	33.5	28.5	62.5	20	23	2.4	7.9
14S	40.2	34.7	69.5	24	26	5.8	11.2
16S	44.4	41.35	72.2	27	28.5	8	13.5
16	-	-	-	-	-	-	-
18	49	43.5	83.5	30	32	9.6	15.9
20	51.5	46	83.5	32	37.5	11.3	19
22	56	50.5	85.5	37	37.5	11.3	19
24	60	54	92.5	40	43.5	15.5	23.8
28	67	61	99.5	45	43.5	15.5	23.8
32	76	69	104	52	54	23.4	31.8
36	82	73.5	108.5	58	58	25.4	35
40	88	80	112	63.2	63.5	30	41.3

Dimensions in mm

Dimension "L" can be different from the value indicated according to backshells accessories, wires size and some special insert configurations.

CVBS - Bayonet Connector with protected mating ramps

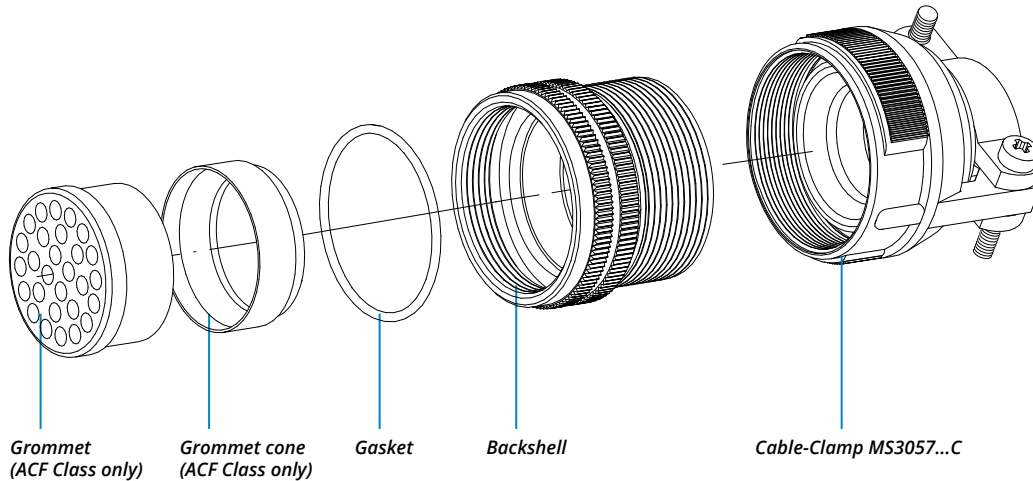

RF	Insulating material	-	Chloroprene rubber
		V	Fluoride rubber
		S	Silicone rubber
		RF	Fire resistant rubber
CVBS	Series Code	CVBS	Bayonet Connector with protected mating ramps
[empty]	Shell Material	-	Aluminum
61	Shell Type	61	Plug Connector Rubber covered coupling nut (short version)
ACF	Connector Class	AC	with waterproof O-ring (IP67)
		ACF	with waterproof O-ring and grommet (IP67)
GG	Coupling Nut Type	GG	Rubber Covered
T	Connector Modification**	T	With plastic caps

20-27	Insert Arrangement	Size - Type	
S	Contact Gender	S	Socket contacts
		P	Pin contacts
X	Polarization Code**	Alternate Positions	
CR	Contact Termination	-	Solder contacts
		CR	Crimp contacts
		LC	Less contacts
CD5	Contact Plating	-	Silver plating
		CD5	Gold plating
		F5	Electroless nickel (*)
		F7	Black epoxy varnish (*)
F7	Shell finish	F16	CCF - Black passivation (*) - conductive
N	Modification Code**	F26	hard anodization (*)
		N	Consult our sales office
S		S	

P/N Sample: RF CVBS 61ACFGGT 20-27SX CR CD5 F7 N

(*) RoHS compliance

(**) If required

CVBS - Bayonet Connector with protected mating ramps

Plug Connector with rubber covered coupling nut (short version) (61..GG) with Backshell Class (DA..M - RA..M DA..PG - RA..PG)

Connector with backshell provided with an internal Metric or PG thread suitable for Cable Glands or conduit adapters. Rubber covered coupling nut (short version) able to protect against dust and impact.

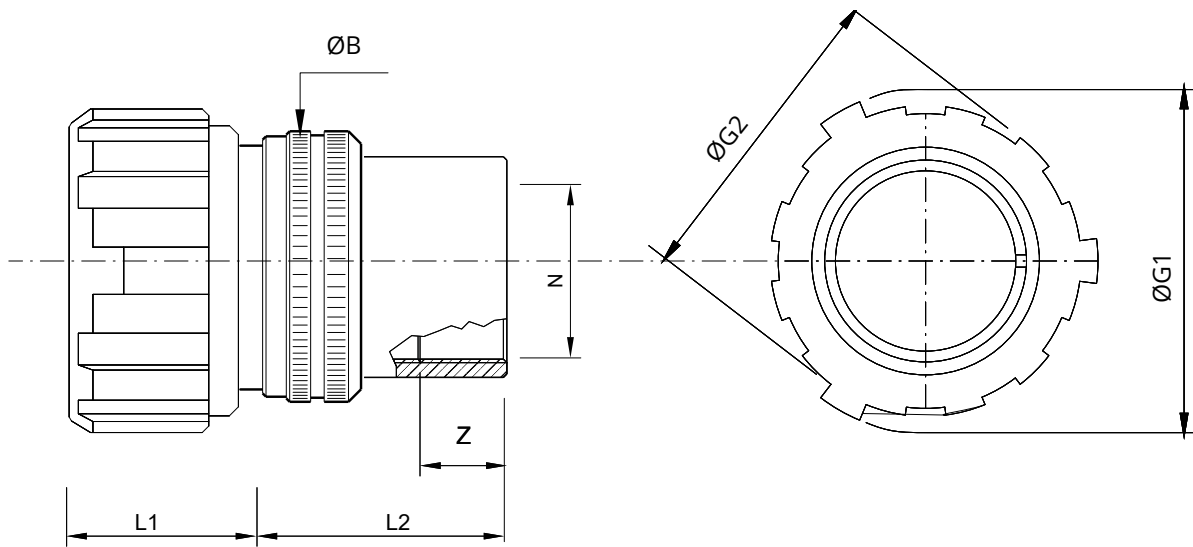

Shell size	ØG1	ØG2	ØB ±0.2	Z min	L1	N Backshell Metric thread	L2 M	N Backshell PG Thread	L2 PG
10SL	33.5	28.5	20	8	21	M12 - M16	32	(PG9) - PG13.5	26
14S	40.2	34.7	24	9	22	M12 - M16 - (M20) - (M25)	30	(PG9) - PG11 - PG13.5 - (PG16)	30
16S	44.4	41.35	27	9	23	(M16) - M20	40	PG13.5 - (PG16)	38
16	-	-	-	-	-	-	-	-	-
18	49	43.5	30	9	28	M20 - M25	50	(PG11) - (PG13.5) - PG16 - PG21	50
20	51.5	46	32	9	28	M16 - M20 - M25 - (M32)	50	PG11-PG13.5-PG16-PG21-PG29	50
22	56	50.5	37	10	29	M16 - M20 - M25 - M32	50	PG13.5 - (PG16) - (PG29)	50
24	60	54	40	10	29	M20 - M25 - M32 - M40	50	PG16 - PG21 - PG29	50
28	67	61	45	10	29	(M25) - M32 - M40	63	PG21 - PG29 - PG36	60
32	76	69	52	10	31	(M25) - (M32) - M40	55	PG21 - (PG29) - PG36	60
36	82	73.5	58	13	31	M40 - M50	56	PG29 - (PG36) - (PG42)	65
40	88	80	63.8	13	32	M40 - (M50) - M63	65	PG29 - (PG36) - (PG42) - (PG48)	65

Dimensions in mm

Dimensions "L1 and L2" can be different from the value indicated according to backshells accessories, wires size and some special insert configurations.

(...) The threads in parentheses are versions on request with non standard backshell length (the dimensions L2 and Z are different from this page indication).

Please consult our sales office for the specific dimensions.

CVBS - Bayonet Connector with protected mating ramps

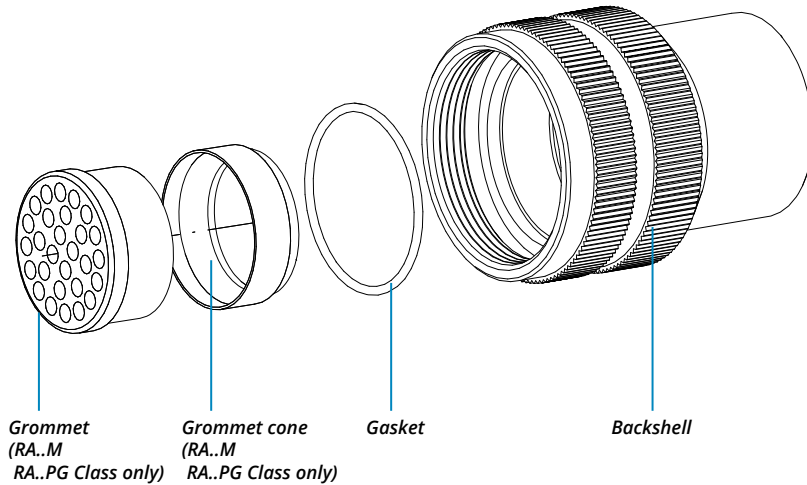

RF	Insulating material	-	Chloroprene rubber
		V	Fluoride rubber
		S	Silicone rubber
		RF	Fire resistant rubber
CVBS	Series Code	CVBS	Bayonet Connector with protected mating ramps
[]	Shell Material	-	Aluminum
61	Shell Type	61	Plug Connector Rubber covered coupling nut (short version)
DA	Connector Class	DA	with waterproof O-ring (IP67***)
		RA	with waterproof O-ring and grommet (IP67***)
GG	Coupling Nut Type	GG	Rubber Covered
T	Connector Modification**	T	With plastic caps
20-27	Insert Arrangement		Size - Type

S	Contact Gender	S	Socket contacts
		P	Pin contacts
X	Polarization Code**		Alternate Positions
M12	Backshell internal thread	M	Provided with an internal Metric thread
		PG	Provided with an internal PG thread
CR	Contact Termination	-	Solder contacts
		CR	Crimp contacts
		LC	Less contacts
CD5	Contact Plating	-	Silver plating
		CD5	Gold plating
		F5	Electroless nickel (*)
		F7	Black epoxy varnish (*)
F7	Shell finish	F16	CCF - Black passivation (*) - conductive
		F26	hard anodization (*)
		N	
N	Modification Code**	N	Consult our sales office
		S	

*** Protection degree: IP 67 (only in the mating area with mated connectors) according to EN 60529 (*) RoHS compliance (***) If required

P/N Sample: RF CVBS 61DAGGT 20-27SX M12 CR CD5 F7 N

CVBS - Bayonet Connector with protected mating ramps

Plug Connector with rubber covered coupling nut (short version) (61..GG) with Backshell Class (AST - ST)

Connector with backshell with internal cable retention system (on request ST1/ST2 with clamps for cable diameter reduction) with an external unef thread. Rubber covered coupling nut (short version) able to protect against dust and impact.

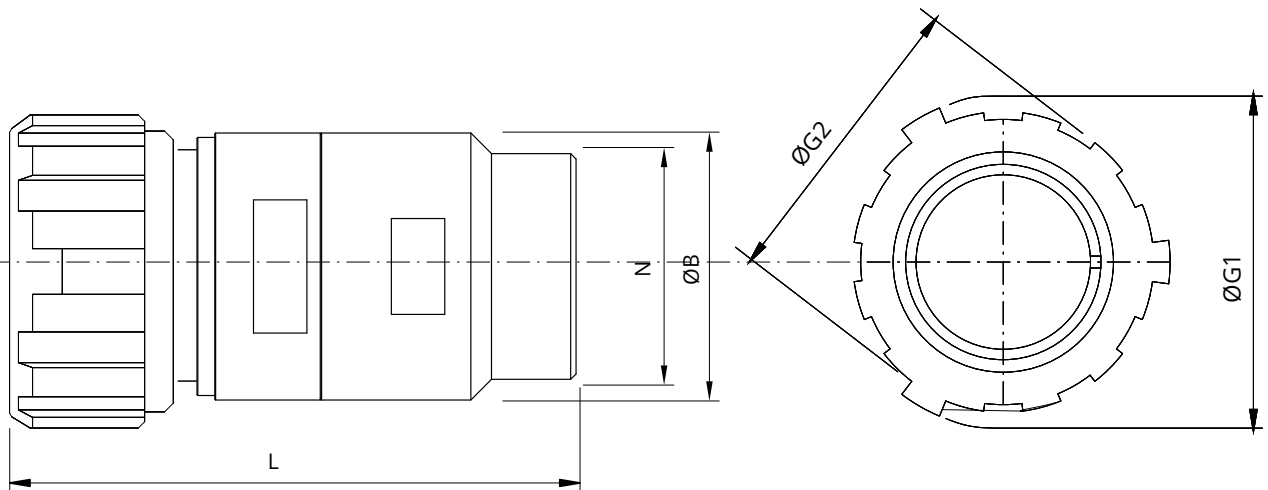

Shell size	ØG1	ØG2	ØB ±0.2	L	N Backshell Thread in inches	Cable Range		
						ST	ST1	ST2
18	49	43.5	30	90	1"-20 UNEF	14-9	9-4	*
20	51.5	46	32	90	1" 3/16-18 UNEF	19-14	14-9	*
22	56	50.5	38	90	1" 3/16-18 UNEF	19-14	14-9	*
24	60	54	45	100	1" 7/16-18 UNEF	23-18	18-13	*
28	67	61	48	100	1" 7/16-18 UNEF	23-18	18-13	*
32	76	69	55	110	1" 3/4-18 UNS	31-25	25-19	19-13
36	82	73.5	58	115	2"-18 UNS	33-25	25-18	*
40	88	80	65	115	2"1/4-16 UN	39-31	31-24	24-16

Dimensions in mm

* On request (please consult our Sales Office)

Dimension "L" can be different from the value indicated according to backshells accessories, wires size and some special insert configurations.

CVBS - Bayonet Connector with protected mating ramps

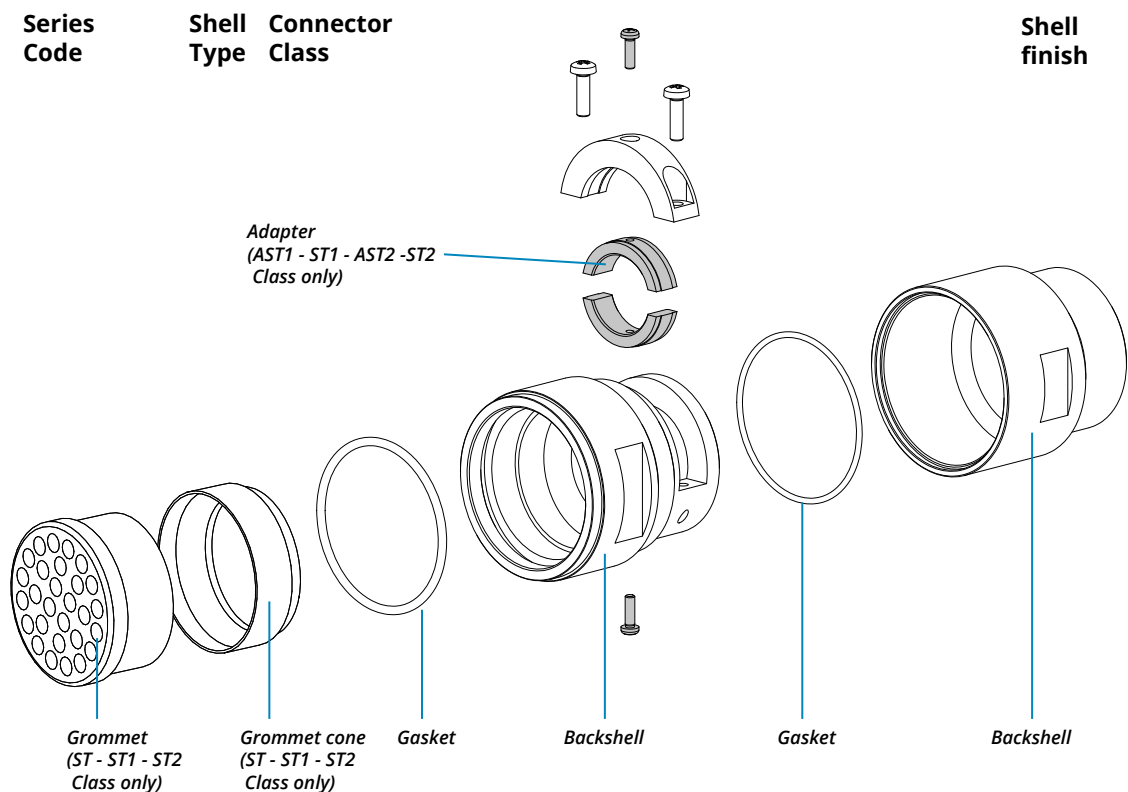

RF	Insulating material	-	Chloroprene rubber
		V	Fluoride rubber
		S	Silicone rubber
		RF	Fire resistant rubber
CVBS	Series Code	CVBS	Bayonet Connector with protected mating ramps
	Shell Material	-	Aluminum
61	Shell Type	61	Plug Connector Rubber covered coupling nut (short version)
		AST	with waterproof O-ring (IP67***)
		ST	with waterproof O-ring and grommet (IP67***)
ST	Connector Class	AST1	with waterproof O-ring (IP67***)
		ST1	with waterproof O-ring and grommet (IP67***)
		AST2	with waterproof O-ring (IP67***)
		ST2	with waterproof O-ring and grommet (IP67***)
GG	Coupling Nut Type	GG	Rubber Covered

T	Connector Modification**	T	With plastic caps
20-27	Insert Arrangement		Size - Type
S	Contact Gender	S	Socket contacts
		P	Pin contacts
X	Polarization Code**		Alternate Positions
CR	Contact Termination	-	Solder contacts
		CR	Crimp contacts
		LC	Less contacts
CD5	Contact Plating	-	Silver plating
		CD5	Gold plating
F7	Shell finish	F5	Electroless nickel (*)
		F7	Black epoxy varnish (*)
		F16	CCF - Black passivation (*) - conductive
		F26	hard anodization (*)
N	Modification Code**	N	Consult our sales office
		S	

*** Protection degree: IP 67 (only in the mating area with mated connectors) according to EN 60529 (*) RoHS compliance (**) If required

P/N Sample: RF CVBS 61STGGT 20-27SX CR CD5 F7 N

CVBS - Bayonet Connector with protected mating ramps

Plug Connector with rubber covered coupling nut (short version) (61..GG) with Backshell Class (AST..M - ST..M)

Connector with backshell with internal cable retention system (on request ST1/ST2 with clamps for cable diameter reduction) with an internal Metric thread. Rubber covered coupling nut (short version) able to protect against dust and impact.

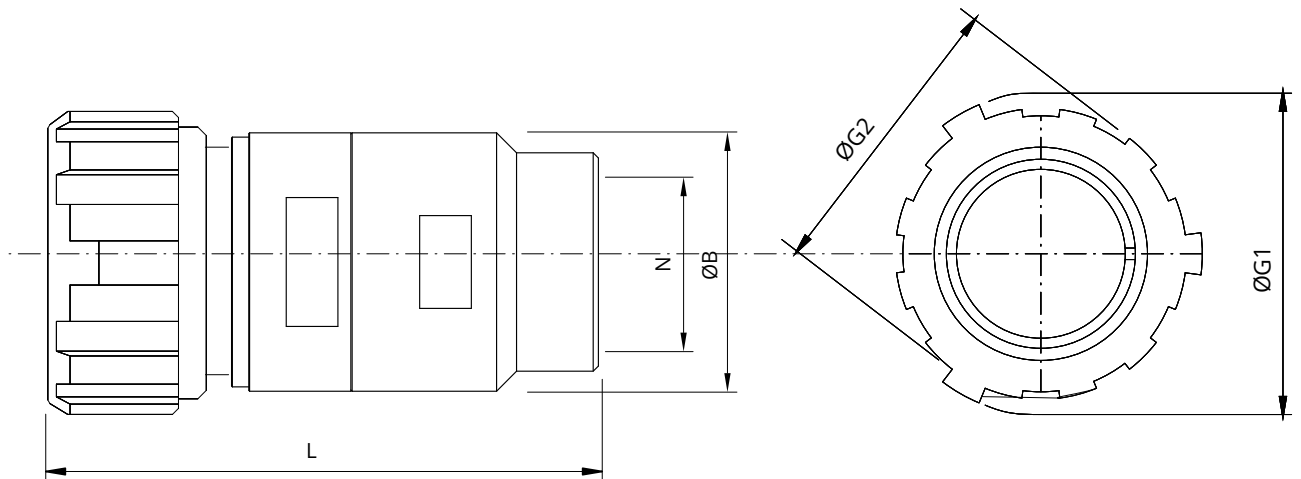

Shell size	ØG1	ØG1	ØB ±0.2	L	N Backshell Thread Metric	Cable Range ST	ST1	ST2
18	49	43.5	30	90	M16 - M20	14-9	9-4	*
20	51.5	46	32	90	M20	19-14	14-9	*
22	56	50.5	38	90	M20	19-14	14-9	*
24	60	54	45	100	M25	23-18	18-13	*
28	67	61	48	100	M25	23-18	18-13	*
32	76	69	55	110	M32 - M40	31-25	25-19	19-13
36	82	73.5	58	115	M32 - M40	33-25	25-18	*
40	88	80	65	115	M40 - M50	39-31	31-24	24-16

Dimensions in mm

* On request (please consult our Sales Office)

Dimension "L" can be different from the value indicated according to backshells accessories, wires size and some special insert configurations.

CVBS - Bayonet Connector with protected mating ramps

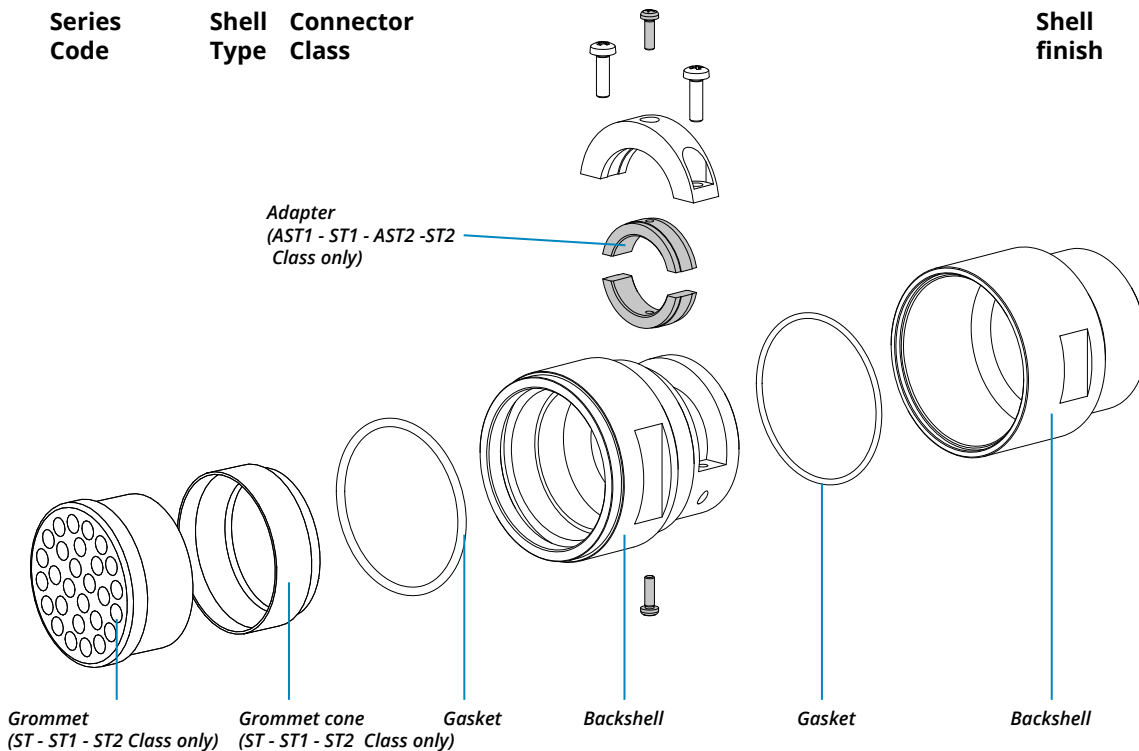

RF	Insulating material	-	Chloroprene rubber
		V	Fluoride rubber
		S	Silicone rubber
		RF	Fire resistant rubber
CVBS	Series Code	CVBS	Bayonet Connector with protected mating ramps
	Shell Material	-	Aluminum
61	Shell Type	61	Plug Connector Rubber covered coupling nut (short version)
		AST	with waterproof O-ring (IP67***)
		ST	with waterproof O-ring and grommet (IP67***)
ST	Connector Class	AST1	with waterproof O-ring (IP67***)
		ST1	with waterproof O-ring and grommet (IP67***)
		AST2	with waterproof O-ring (IP67***)
		ST2	with waterproof O-ring and grommet (IP67***)
GG	Coupling Nut Type	GG	Rubber Covered
T	Connector Modification**	T	With plastic caps

20-27	Insert Arrangement	Size - Type	
S	Contact Gender	S	Socket contacts
		P	Pin contacts
X	Polarization Code**		Alternate Positions
M	Backshell internal thread	M	Provided with an internal Metric thread
CR	Contact Termination	-	Solder contacts
		CR	Crimp contacts
		LC	Less contacts
CD5	Contact Plating	-	Silver plating
		CD5	Gold plating
F7	Shell finish	F5	Electroless nickel (*)
		F7	Black epoxy varnish (*)
		F16	CCF - Black passivation (*) - conductive
		F26	hard anodization (*)
N	Modification Code**	N	Consult our sales office
		S	

*** Protection degree: IP 67 (only in the mating area with mated connectors) according to EN 60529 (*) RoHS compliance (***) If required

P/N Sample: RF CVBS 61STGGT 20-27SX M CR CD5 F7 N

CVBS - Bayonet Connector with protected mating ramps

Plug Connector with rubber covered coupling nut (short version) (61..GG) with Backshell Class (AST..FS - ST..FS)

Connector with backshell with internal cable retention system (on request ST1/ST2 with clamps for cable diameter reduction) with a special adapter for rubber conduits. Rubber covered coupling nut (short version) able to protect against dust and impact.

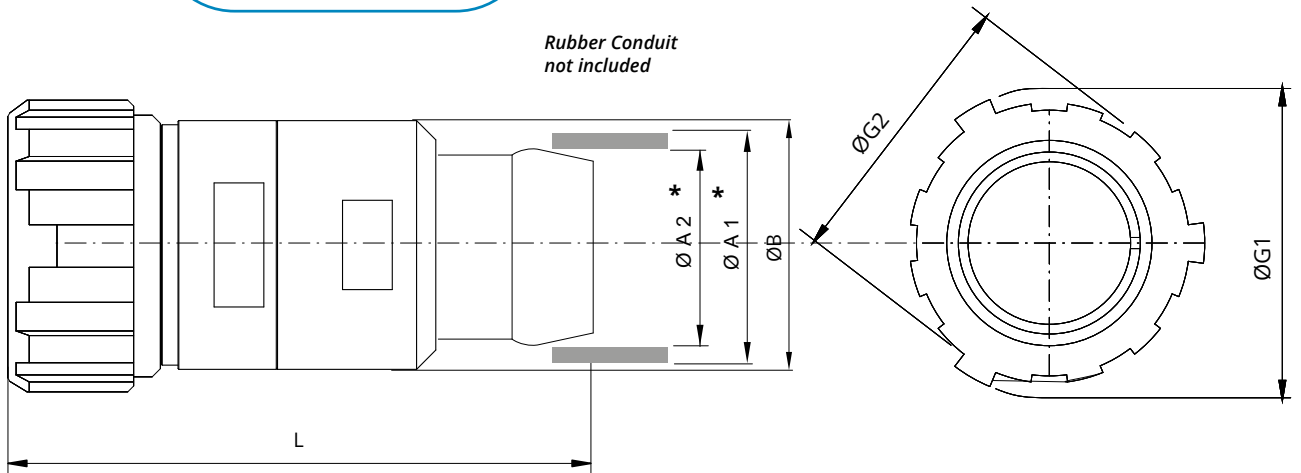

Please consult our Sales Office for further details about this dimension and according to conduit size.

Backshell Conduit Size	ØA1*	ØA2*
FS2015	20	15
FS2520	25	20
FS2722	27	22
FS3328	33	28
FS3530	35	30
FS4035	40	35
FS4540	45	40
FS5045	50	45
FS5945	59	45

Shell size	ØG1	ØG1	ØB ±0.2	L	Cable Range		
					ST	ST1	ST2
18	49	43.5	30	120	14-9	9-4	*
20	51.5	46	32	120	19-14	14-9	*
22	56	50.5	38	120	19-14	14-9	*
24	60	54	45	125	23-18	18-13	*
28	67	61	48	125	23-18	18-13	*
32	76	69	55	139	31-25	25-19	19-13
36	82	73.5	58	139	33-25	25-18	*
40	88	80	65	139	39-31	31-24	24-16

Dimensions in mm

* On request (please consult our Sales Office)

Dimension "L" can be different from the value indicated according to backshells accessories, wires size and some special insert configurations.

CVBS - Bayonet Connector with protected mating ramps



Series Code

Shell Type

Connector Class

Backshell Conduits size

Shell finish

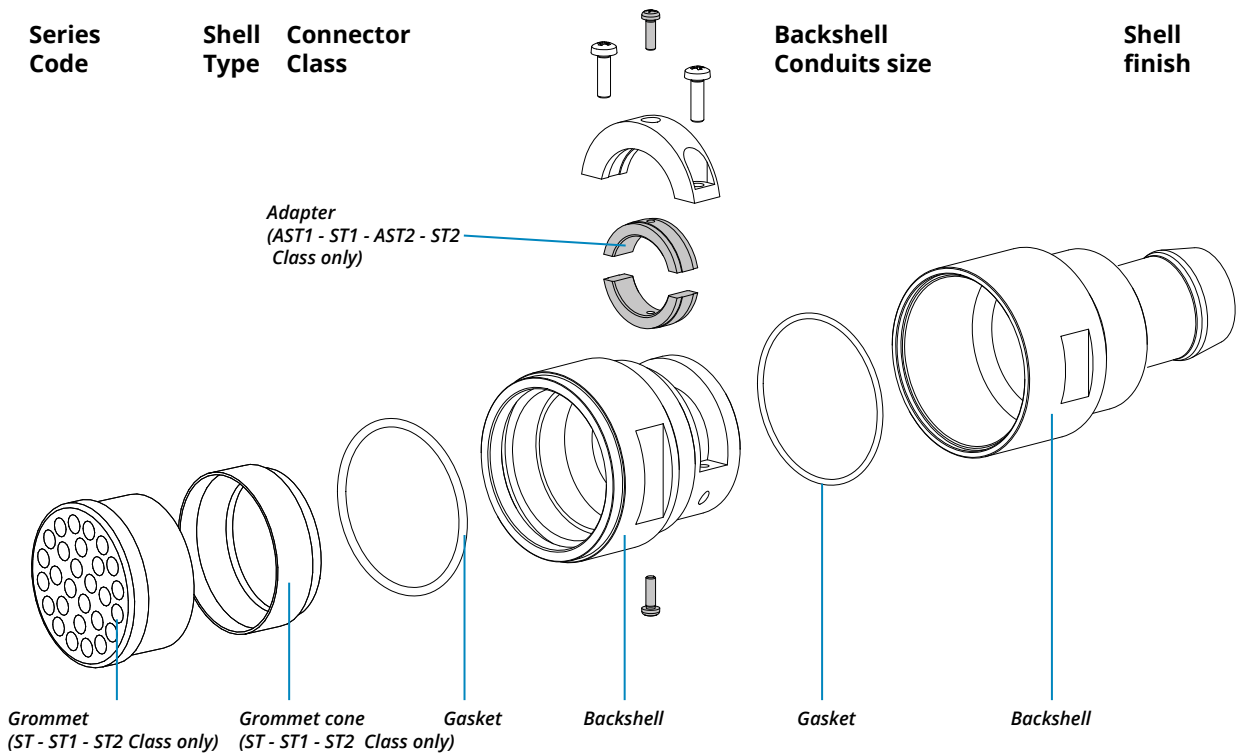

RF	Insulating material	-	Chloroprene rubber	20-27	Insert Arrangement	Size - Type	
		V	Fluoride rubber	S	Contact Gender	S	Socket contacts
		S	Silicone rubber			P	Pin contacts
		RF	Fire resistant rubber	X	Polarization Code**	Alternate Positions	
CVBS	Series Code	CVBS	Bayonet Connector with protected mating ramps	FS	Backshell Conduits size	FS	Provided with a special adapter for rubber conduits
[]	Shell Material	-	Aluminum	2015	Conduit Size	xxxx	ØA1/ØA2
61	Shell Type	61	Plug Connector Rubber covered coupling nut (short version) with waterproof O-ring (IP67***)	CR	Contact Termination	-	Solder contacts
		AST	with waterproof O-ring and grommet (IP67***)			CR	Crimp contacts
		ST	with waterproof O-ring and grommet (IP67***)			LC	Less contacts
ST	Connector Class	AST1	with waterproof O-ring (IP67***)	CD5	Contact Plating	-	Silver plating
		ST1	with waterproof O-ring and grommet (IP67***)			CD5	Gold plating
		AST2	with waterproof O-ring (IP67***)	F7	Shell finish	F5	Electroless nickel (*)
		ST2	with waterproof O-ring and grommet (IP67***)			F7	Black epoxy varnish (*)
T	Connector Modification**	T	With plastic caps			F16	CCF - Black passivation (*) - conductive
GG	Coupling Nut Type	GG	Rubber Covered			F26	hard anodization (*)
				N	Modification Code**	N	Consult our sales office
						S	Consult our sales office

*** Protection degree: IP 67 (only in the mating area with mated connectors) according to EN 60529 (*) RoHS compliance (**) If required

P/N Sample: RF CVBS 61STGGT 20-27SX FS2015 CR CD5 F7 N

CVBS - Bayonet Connector with protected mating ramps

Plug Connector with rubber covered coupling nut (short version) (81..GG) with 90° Elbow Class (A - DA - RA)

Connector with 90° elbow provided with an external thread suitable for MS3057...A or C type Cable-Clamps (to be ordered separately). Rubber covered coupling nut (short version) able to protect against dust and impact.

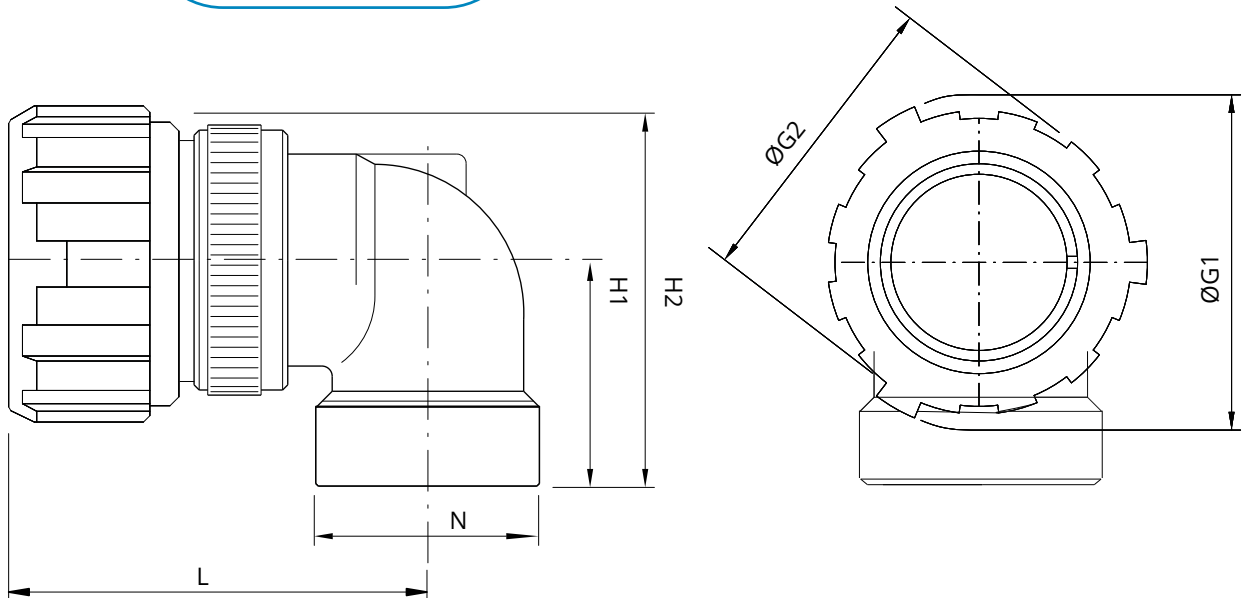

Shell size	ØG1	ØG2	L max	H1 max	H2 max	N Backshell Thread in inches
18	49	43.5	61.5	31	55.5	1"-20 UNEF
20	51.5	46	63.5	33	58.8	1" 3/16-18 UNEF
22	56	50.5	65.5	35	63	1" 3/16-18 UNEF
24	60	54	69	38	68	1" 7/16-18 UNEF
28	67	61	69	40	73.5	1" 7/16-18 UNEF
32	76	69	74	46	84	1" 3/4-18 UNS
36	82	73.5	77.5	49	90	2"-18 UNS
40	88	80	82.5	53	97	2" 1/4-16 UN

Dimensions in mm

Dimension "L" can be different from the value indicated according to backshells accessories, wires size and some special insert configurations.

CVBS - Bayonet Connector with protected mating ramps

RF	CVBS		81	DA	GG	T	20-27	S	X		CR	CD5	F7		N
Series Code		Shell Type		Connector Class								Shell finish			

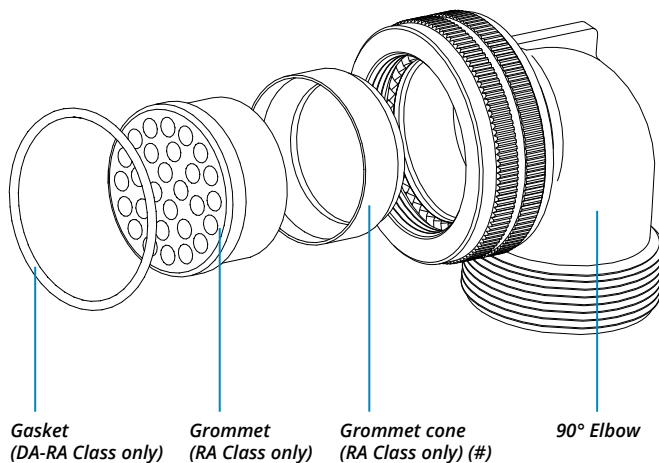

RF	Insulating material	-	Chloroprene rubber	20-27	Insert Arrangement		Size - Type		
		V	Fluoride rubber			S	Contact Gender	S	Socket contacts
		S	Silicone rubber					P	Pin contacts
		RF	Fire resistant rubber			X	Polarization Code**		Alternate Positions
CVBS	Series Code	CVBS	Bayonet Connector with protected mating ramps	CR	Contact Termination	-	Solder contacts		
	Shell Material	-	Aluminum			CR	Crimp contacts		
81	Shell Type	81	Plug Connector with 90° elbow Rubber covered coupling nut (short version)			LC	Less contacts		
DA	Connector Class	A	non watertight	CD5	Contact Plating	-	Silver plating		
		DA	with waterproof O-ring (IP67***)			F5	Electroless nickel (*)		
GG	Coupling Nut Type	RA	with waterproof O-ring and grommet (IP67***) (#)	F7	Shell finish	F7	Black epoxy varnish (*)		
		GG	Rubber Covered			F16	CCF - Black passivation (*) - conductive		
T	Connector Modification**	T	With plastic caps	N	Modification Code**	N	Consult our sales office		
				S		S	Consult our sales office		

*** Protection degree: IP 67 (only in the mating area with mated connectors) according to EN 60529 (*) RoHS compliance (**) If required

P/N Sample: RF CVBS 81DAGGT 20-27SX CR CD5 F7 N

(#) In some sizes the grommet cone is not needed

CVBS - Bayonet Connector with protected mating ramps

Plug Connector with rubber covered coupling nut (short version) (81..GG) with 90° Elbow Class (AST..M - ST..M)

Connector with backshell with internal cable retention system (on request ST1/ST2 with clamps for cable diameter reduction) with an internal Metric thread. Rubber covered coupling nut (short version) able to protect against dust and impact.

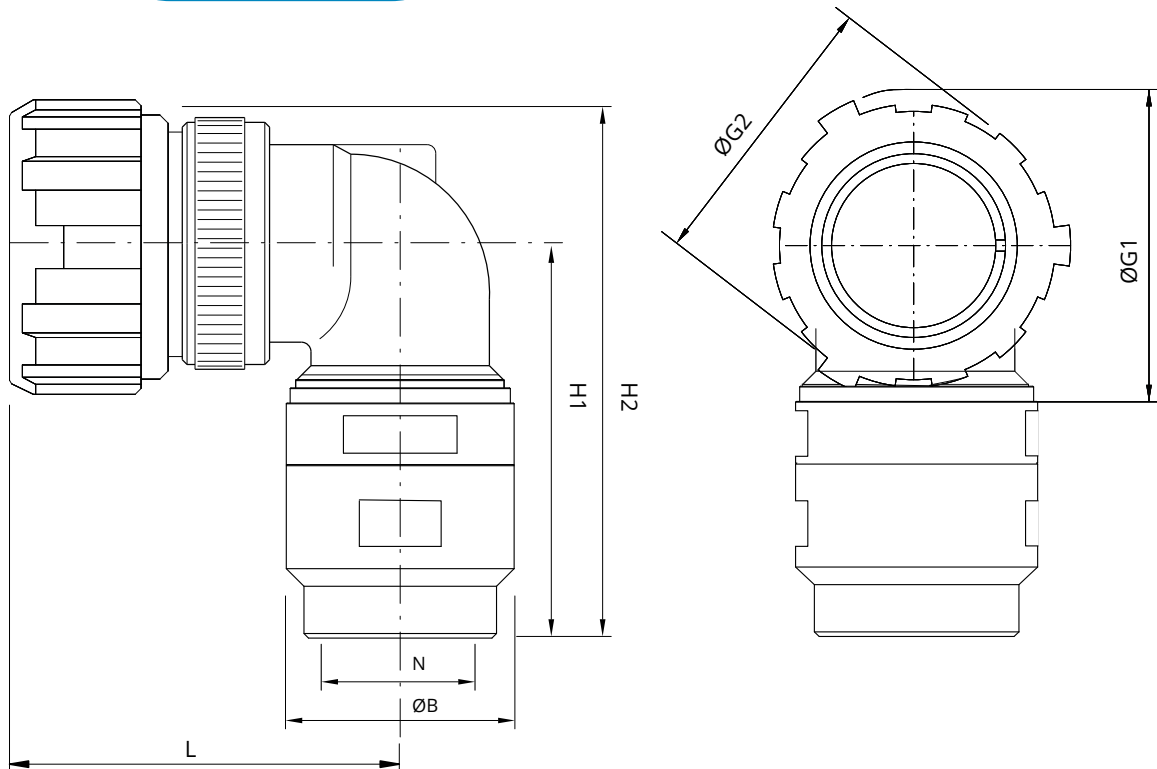

Shell size	ØG1	ØG2	ØB ±0.2	L max	H1	H2	N Backshell Thread Metric	Cable Range		
								ST	ST1	ST2
18	49	43.5	30	61.5	*	*	M16 - M20	14-9	9-4	*
20	51.5	46	32	63.5	93	119	M20 - M32	19-14	14-9	*
22	56	50.5	38	65.5	*	*	M20	19-14	14-9	*
24	60	54	45	69	*	*	M25	23-18	18-13	*
28	67	61	48	69	*	*	M25	23-18	18-13	*
32	76	69	55	74	*	*	M32 - M40	31-25	25-19	19-13
36	82	73.5	58	78	120	162	M32 - M40	33-25	25-18	*
40	88	80	65	82	135	180	M40 - M50	39-31	31-24	24-16

Dimensions in mm

* On request (please consult our Sales Office)

Dimension "L" can be different from the value indicated according to backshells accessories, wires size and some special insert configurations.

CVBS - Bayonet Connector with protected mating ramps



Series Code

Shell Type Connector Class

Shell finish

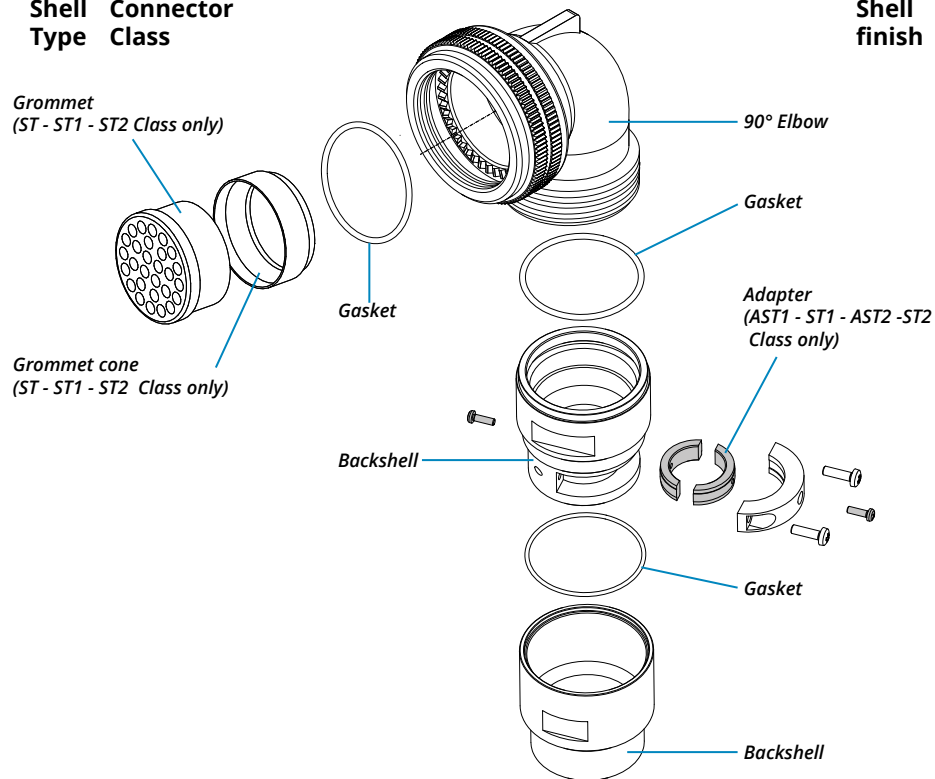

RF	Insulating material	- Chloroprene rubber V Fluoride rubber S Silicone rubber RF Fire resistant rubber	20-27	Insert Arrangement	Size - Type
CVBS	Series Code	CVBS Bayonet Connector with protected mating ramps	S	Contact Gender	S Socket contacts P Pin contacts
	Shell Material	- Aluminum	X	Polarization Code**	Alternate Positions
81	Shell Type	81 Plug Connector with 90° elbow Rubber covered coupling nut (short version) AST with waterproof O-ring (IP67***) ST with waterproof O-ring and grommet (IP67***) AST1 with waterproof O-ring (IP67***) ST1 with waterproof O-ring and grommet (IP67***) AST2 with waterproof O-ring (IP67***) ST2 with waterproof O-ring and grommet (IP67***)	M	Backshell internal thread	M Provided with an internal Metric thread
ST	Connector Class		CR	Contact Termination	- Solder contacts CR Crimp contacts LC Less contacts
GG	Coupling Nut Type	GG Rubber Covered	CD5	Contact Plating	- Silver plating CD5 Gold plating
T	Connector Modification**	T With plastic caps	F7	Shell finish	F5 Electroless nickel (*) F7 Black epoxy varnish (*) F16 CCF - Black passivation (*) - conductive F26 hard anodization (*)
			N	Modification Code**	N S Consult our sales office

*** Protection degree: IP 67 (only in the mating area with mated connectors) according to EN 60529 (*) RoHS compliance (***) If required

P/N Sample: RF CVBS 81STGGT 20-27SX M CR CD5 F7 N

CVBS - Bayonet Connector with protected mating ramps

Front Mounting Receptacle (26) unable to Accept Rear Accessories

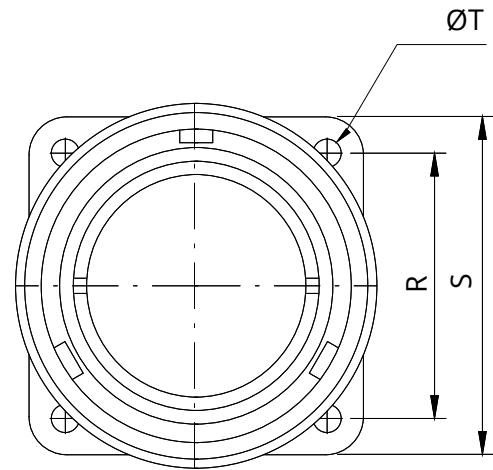
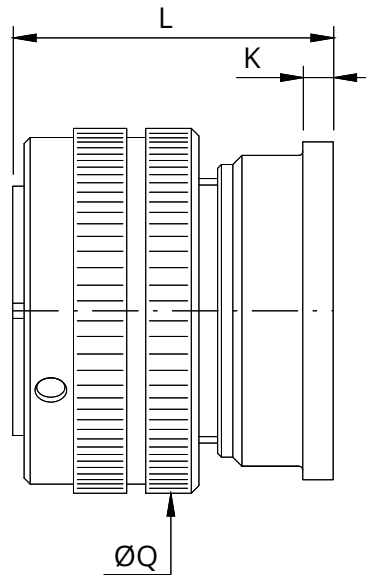
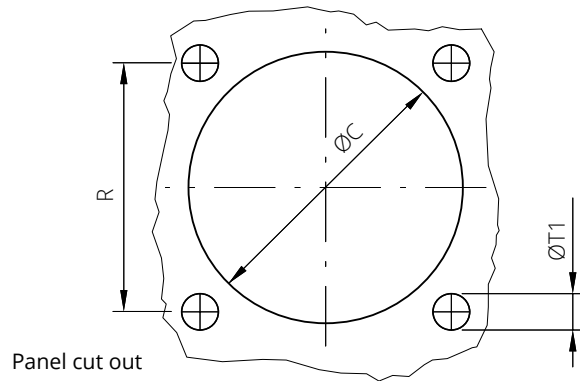

Shell size	L	K ±0.2	ØQ	R ±0.1	S ±0.3	ØT ±0.2	ØT1 Through holes	ØC ±0.2
10SL	37	2.8	23.2	18.2	25.4	3.1	3.4	17
14S	37.2	3.2	29.5	23	30.2	3.1	3.4	20
16S	37.2	3.2	33	24.6	32.5	3.1	3.4	23
16	38.3	3.2	33.6	24.6	32.5	3.1	3.4	23
18	38.3	4	37	27	34.9	3.1	3.4	26.5
20	38.3	4	41	29.4	38.1	3.1	3.4	30
22	38.3	4	43	31.8	41	3.1	3.4	33
24	40.8	4	48	34.9	44.5	3.7	3.9	36
28	41	4	53	39.7	50.8	3.7	3.9	42
32	43.9	4	60	44.5	57	4.4	4.5	48.5
36	45	4	66.2	49.2	63.5	4.4	4.5	55
40	45	4	72.4	55.6	69.8	4.4	4.5	61

Dimensions in mm

Dimension "L" can be different from the value indicated according to wires size and some special insert configurations.

CVBS - Bayonet Connector with protected mating ramps

RF CVBS 26 T 20-27 S X CR CD5 F7 G N

Series Code Shell Material Type

Shell finish

RF	Insulating material	-	Chloroprene rubber
		V	Fluoride rubber
		S	Silicone rubber
		RF	Fire resistant rubber
CVBS	Series Code	CVBS	Bayonet Connector with protected mating ramps
	Shell Material	-	Aluminum
26	Shell Type	26	Front mounting receptacle connector with coupling nut, unable to accept rear accessories
T	Connector Modification**	T	With plastic caps
		FF	Receptacle connector with threaded holes
		-	Receptacle connector with through holes
		FS	Receptacle connector with countersunk holes
20-27	Insert Arrangement		Size - Type
S	Contact Gender	S	Socket contacts
		P	Pin contacts
X	Polarization Code**		Alternate Positions
CR	Contact Termination	-	Solder contacts
		CR	Crimp contacts
		LC	Less contacts
		DS	PCB contacts
CD5	Contact Plating	-	Silver plating
		CD5	Gold plating
F7	Shell finish	F5	Electroless nickel (*)
		F7	Black epoxy varnish (*)
		F16	CCF - Black passivation (*) - conductive
		F26	hard anodization (*)
G	Panel Gasket	-	Without gasket
		G	With waterproof panel gasket
		G2	With shielded panel gasket
		G3	With waterproof shielded panel gasket
N	Modification Code**	N	Consult our sales office
		S	

P/N Sample: RF CVBS 26T 20-27SX CR CD5 F7 G N

(*) RoHS compliance

(**) If required

CVBS - Bayonet Connector with protected mating ramps

Front Mounting Receptacle, heavy duty coupling nut (265) unable to Accept Rear Accessories

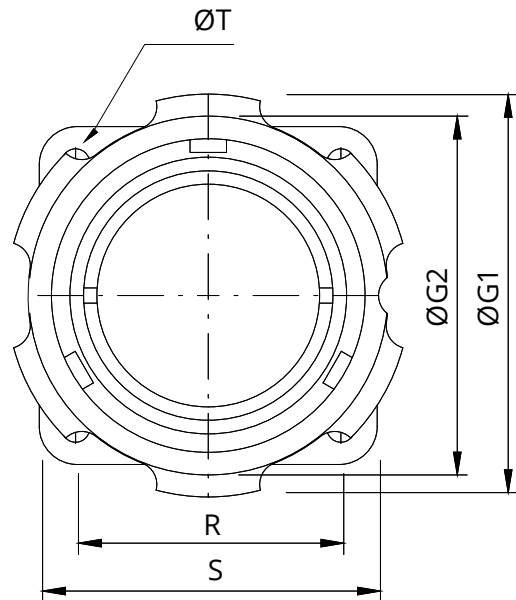
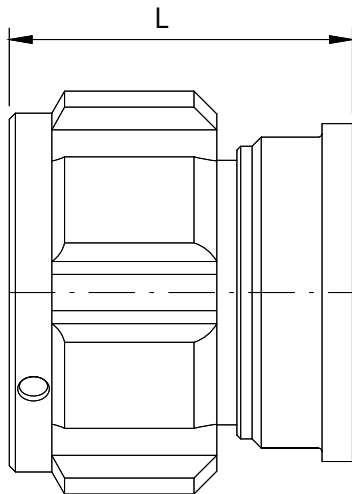
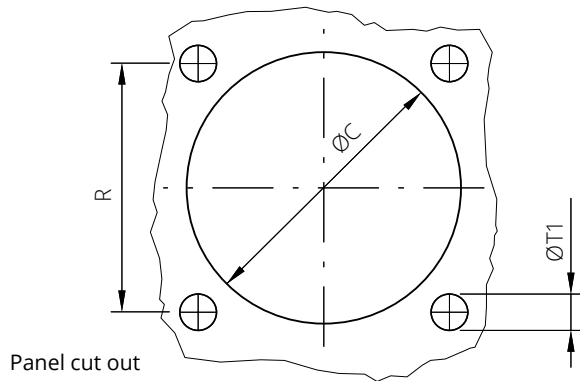

Shell size	L	ØG1 ±0.5	ØG2 ±0.5	R ±0.1	S ±0.3	ØT ±0.2	ØT1 Through holes	ØC ±0.2
20 *	38.3	46.4	40.9	29.4	38.1	3.1	3.4	30
24	40.8	53	47.4	34.9	44.5	3.7	3.9	36
28	41	60.3	54.8	39.7	50.8	3.7	3.9	42
32	43.9	67.1	61.8	44.5	57	4.4	4.5	48.5
40	45	79.1	73.6	55.6	69.8	4.4	4.5	61

(*) Consult our Sales Office for the availability of this size

Dimensions in mm

Dimension "L" can be different from the value indicated according to wires size and some special insert configurations.

CVBS - Bayonet Connector with protected mating ramps

RF	CVBS		265		T	20-27	S	X		CR	CD5	F7	G	N
Series Code		Shell Material Type											Shell finish	

RF	Insulating material	-	Chloroprene rubber
		V	Fluoride rubber
		S	Silicone rubber
		RF	Fire resistant rubber
CVBS	Series Code	CVBS	Bayonet Connector with protected mating ramps
	Shell Material	-	Aluminum
265	Shell Type	265	Front mounting receptacle connector with heavy duty coupling nut, unable to accept rear accessories
T	Connector Modification**	T	With plastic caps
		FF	Receptacle connector with threaded holes
		-	Receptacle connector with through holes
		FS	Receptacle connector with countersunk holes
20-27	Insert Arrangement		Size - Type
S	Contact Gender	S	Socket contacts
		P	Pin contacts
X	Polarization Code**		Alternate Positions
CR	Contact Termination	-	Solder contacts
		CR	Crimp contacts
		LC	Less contacts
		DS	PCB contacts
CD5	Contact Plating	-	Silver plating
		CD5	Gold plating
F7	Shell finish	F5	Electroless nickel (*)
		F7	Black epoxy varnish (*)
		F16	CCF - Black passivation (*) - conductive
		F26	hard anodization (*)
G	Panel Gasket	-	Without gasket
		G	With waterproof panel gasket
		G2	With shielded panel gasket
		G3	With waterproof shielded panel gasket
N	Modification Code**	N	Consult our sales office
		S	

P/N Sample: RF CVBS 265T 20-27SX CR CD5 F7 G N

(*) RoHS compliance

(**) If required

CVBS - Bayonet Connector with protected mating ramps

Through-Bulkhead Connector (TB)

Available in the following versions: pin-socket contacts, pin-pin or socket-socket contacts.

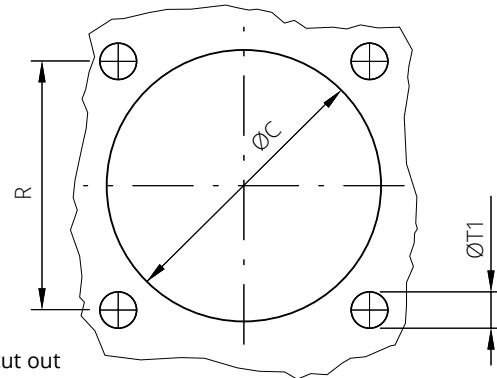

Panel cut out

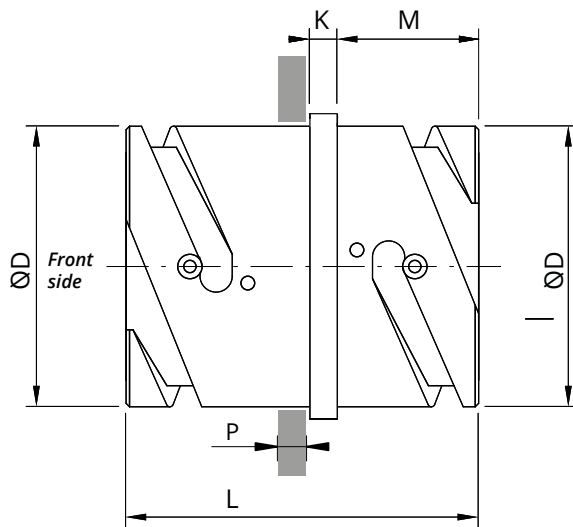

In case of PS contact gender, Socket in Front side.

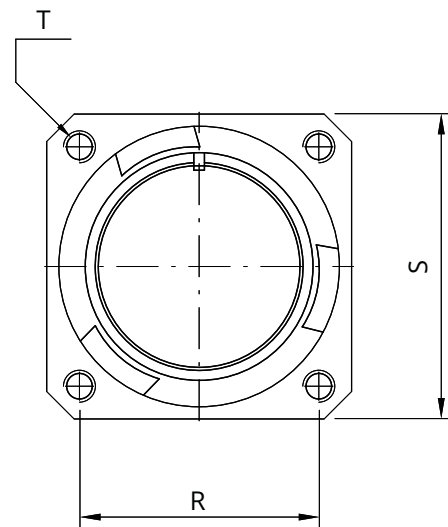

Shell size	ØD +0 -0.15	L	K ±0.2	M ±0.2	R ±0.1	S ±0.3	ØT ±0.2	ØT1 Threaded holes	ØC ±0.2	P Panel Thickness Max Through bulkhead, gasket side mounting connectors
10SL	18.2	37.5	2.8	14.2	18.2	25.4	M4	4.5	19.1	10
14S	24.6	37.5	3.2	14.2	23	30.2	M4	4.5	25.5	9.6
16S	27.4	37.5	3.2	14.2	24.6	32.5	M4	4.5	28.3	9.6
16	27.4	51.4	3.2	19	24.6	32.5	M4	4.5	28.3	13.8
18	30.8	51.4	4	19	27	34.9	M4	4.5	31.7	13
20	34.2	51.6	4	19	29.4	38.1	M4	4.5	35	13
22	37.4	51.4	4	19	31.8	41	M4	4.5	38.3	12.25
24	40.9	51.4	4	20.6	34.9	44.5	M4	4.5	41.8	11.25
28	46.7	51.4	4	20.6	39.7	50.8	M5	5.5	47.6	12.4
32	53.4	51.4	4	22.2	44.5	57	M5	5.5	54.3	9
36	59.6	51.4	4	22.2	49.2	63.5	M5	5.5	60.5	8.3
40	65.5	51.4	4	22.2	55.6	69.8	M5	5.5	66.4	9

Dimensions in mm

Dimension "L" can be different from the value indicated according to wires size and some special insert configurations.

CVBS - Bayonet Connector with protected mating ramps



Series Code Shell Material Type

Shell finish

RF	Insulating material	-	Chloroprene rubber
		V	Fluoride rubber
		S	Silicone rubber
		RF	Fire resistant rubber
CVBS	Series Code	CVBS	Bayonet Connector with protected mating ramps
	Shell Material	-	Aluminum
TB	Shell Type	TB	Through-bulkhead connector.
T	Connector Modification**	T	With plastic caps
		-	Receptacle connector with threaded holes
		FP	Receptacle connector with through holes
		FS	Receptacle connector with countersunk holes
20-27	Insert Arrangement		Size - Type
PS	Contact Gender	PS	Pin + Socket contacts
		SS***	Socket + Socket contacts
		PP	Pin + Pin contacts
X	Polarization Code**		Alternate Positions
CD5	Contact Plating	-	Silver plating
		CD5	Gold plating
		F5	Electroless nickel (*)
F7	Shell finish	F7	Black epoxy varnish (*)
		F16	CCF - Black passivation (*) - conductive
		F26	hard anodization (*)
		-	Without gasket
G	Panel Gasket	G	With waterproof panel gasket
		G2	With shielded panel gasket
		G3	With waterproof shielded panel gasket
		-	Without gasket
N	Modification Code**	N	Consult our sales office
		S	

P/N Sample: RF CVBS TBT 20-27PSX CD5 F7 G N

(*) RoHS compliance

(**) If required

*** On request

CVBS - Bayonet Connector with protected mating ramps

Dummy Receptacle Connector (05)

Useful to hold the plug connectors when not in use.

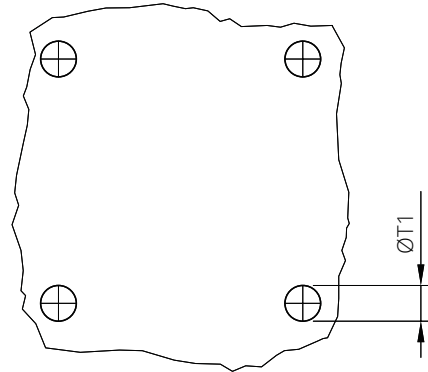

Panel cut out

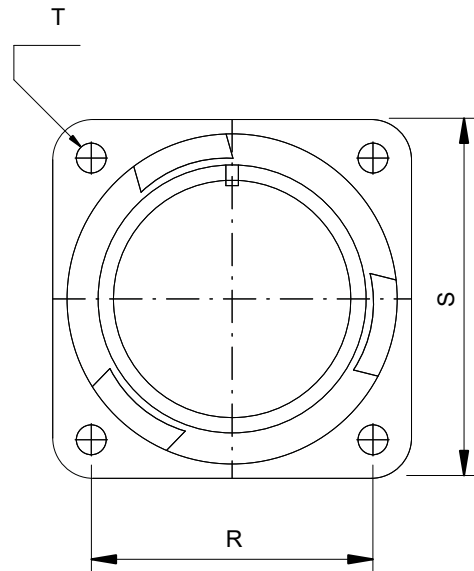
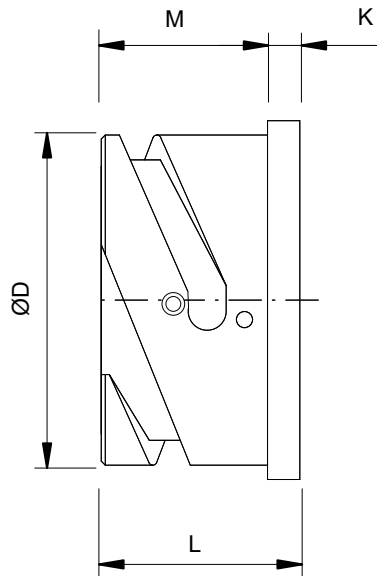

Shell size	ØD +0 -0.15	L	K ±0.2	M ±0.2	R ±0.1	S ±0.3	ØT ±0.2	ØT1 Through holes
10SL	18.2	17	2.8	14.2	18.2	25.4	3.1	3.4
14S	24.6	17.7	3.2	14.5	23	30.2	3.1	3.4
16S	27.4	17.4	3.2	14.2	24.6	32.5	3.1	3.4
16	27.4	22.2	3.2	19	24.6	32.5	3.1	3.4
18	30.8	23	4	19	27	34.9	3.1	3.4
20	34.2	23	4	19	29.4	38.1	3.1	3.4
22	37.4	23.7	4	19.7	31.8	41	3.1	3.4
24	40.9	24.6	4	20.6	34.9	44.5	3.7	3.9
28	46.7	24.6	4	20.6	39.7	50.8	3.7	3.9
32	53.4	26.2	4	22.2	44.5	57	4.4	4.5
36	59.6	26.2	4	22.2	49.2	63.5	4.4	4.5
40	65.5	26.2	4	22.2	55.6	69.8	4.4	4.5

Dimensions in mm

Dimension "L" can be different from the value indicated according to wires size and some special insert configurations.

CVBS - Bayonet Connector with protected mating ramps

	CVBS		05		T	20						F7		S
	Series Code	Shell Material	Shell Type									Shell finish		

CVBS	Series Code	CVBS	Bayonet Connector with protected mating ramps
	Shell Material	-	Aluminum
05	Shell Type	05	Dummy Receptacle Connector
		T	With plastic caps
T	Connector Modification**	FF	Receptacle connector with threaded holes
		-	Receptacle connector with through holes
		FS	Receptacle connector with countersunk holes
20	Shell size		
		F5	Electroless nickel (*)
F7	Shell finish	F7	Black epoxy varnish (*)
		F16	CCF - Black passivation (*) - conductive
		F26	hard anodization (*)
S	Modification Code**	S	Consult our sales office

P/N Sample: CVBS 05T 20 F7 N

(*) RoHS compliance

(**) If required

CVBSG - Bayonet Connector with external insulated coating - Shell - Backshell

RF CVBSG 00 DA T 20-27 S X PG16 CR CD5 F7 G N



CVBSG series has been modified to design safety connectors. The shells of plug connectors have been rubber jacketed. Accessories in rubber material or with rubber protection are also available for cable retention.

Main characteristics:

- These connectors are particularly suitable for applications with mechanical shock
- Rubber jacket and insulating parts are in accordance with EN 45545-2 standards
- Standard panel receptacle supplied with countersunk holes for easy mating with rubber jacketed nuts
- Accessories made of rubber material or with rubber protection are also available for cable retention

Available in several versions suitable for all applications and manufactured in different materials and finishes:

- Aluminum alloy with different types of protection finishes according to RoHS directives.

CVBSG	Series Code	CVBSG	Bayonet Connector with external insulated coating
	Shell Material	-	Aluminum
00	Shell Type	xx	Flange/Plug Shell with ramp/threaded or with nut
DA	Connector Class	xx	With backshell
T	Connector Modification**	T	With plastic caps
		FF	Receptacle connector with threaded holes (to specify for 00/02/05 shell only)
		FP	Receptacle connector with through holes (to specify for 03 shell only)
		FS	Receptacle connector with countersunk holes
PG16	Backshell Conduits size or internal thread	-	Without internal thread
F7	Shell finish	xx	Conduits size or internal thread
		F7	Black epoxy varnish (<i>RoHS compliance</i>)
		F16	CCF - Black passivation - conductive (<i>RoHS compliance</i>)
G	Panel Gasket	F26	Hard anodization (<i>RoHS compliance</i>)
		-	Without gasket
		G	With waterproof panel gasket
		G2	With shielded panel gasket
N	Modification Code**	G3	With waterproof shielded panel gasket
		N	Contacts and hole plugs (Consult our sales office)
		S	Customization (Consult our sales office)

CVBSG - Bayonet Connector with external insulated coating

Front Mounting Receptacle (00) with Backshell Class (DA...M - RA...M)

Connector with backshell provided with an internal Metric or PG thread suitable for Cable Glands or conduit adapters.

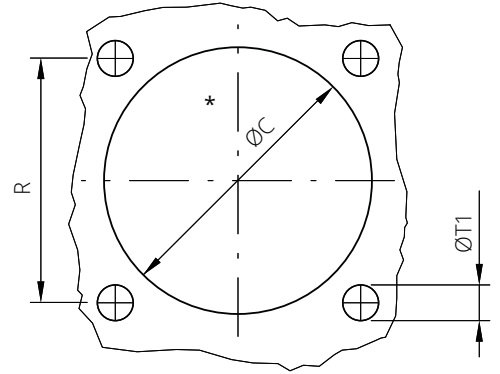
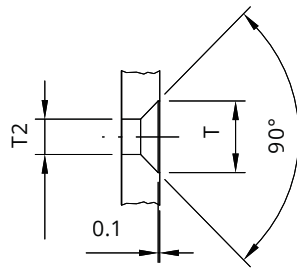

Panel cut out

* For installation with backshell mounted, consult our sales office.

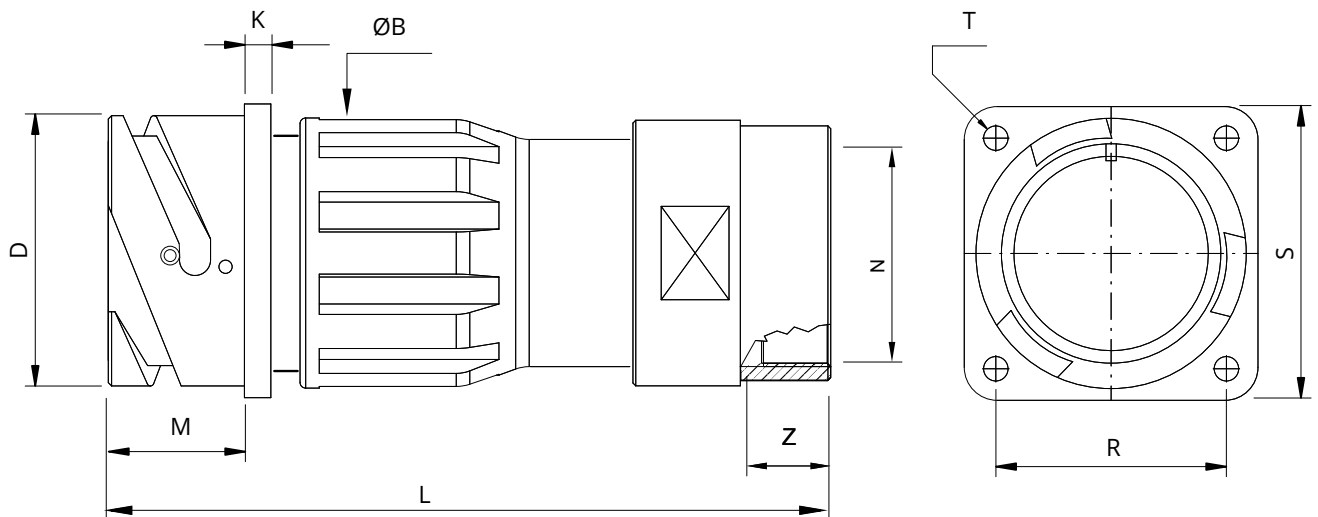

Shell size	ØD +0 -0.15	L max	M ±0.2	K ±0.2	ØB ±0.3	Z min	N Backshell Metric Thread	R ±0.1	S ±0.3	ØT ±0.2	ØT2	ØT1	ØC* ±0.2
18	30.8	99	19	4	37	12	M20	27	34.9	6.5	3.1	3.4	26.5
20	34.2	116	19	4	42	15	M25	29.4	38.1	6.5	3.1	3.4	30
22	37.4	116	19.7	4	45	15	M25	31.8	41	6.5	3.1	3.4	33
24	40.9	136	20.6	4	47.8	16	M32	34.9	44.5	7.5	3.7	3.9	36
28	46.7	136	20.6	4	54.6	16	M32	39.7	50.8	7.5	3.7	3.9	42
32	53.4	140	22.2	4	61.8	16	M32	44.5	57	8	4.4	4.5	48.5
36	59.6	148	22.2	4	65.6	16	M32	49.2	63.5	8.5	4.4	4.5	55
40	65.5	151	22.2	4	74	16	M32	55.6	69.8	8.5	4.4	4.5	61

Dimensions in mm

Dimension "L" can be different from the value indicated according to backshells accessories, wires size and some special insert configurations.

CVBSG - Bayonet Connector with external insulated coating



Series Code **Shell Material Type** **Shell Class** **Connector Class**

Backshell internal thread

Shell finish

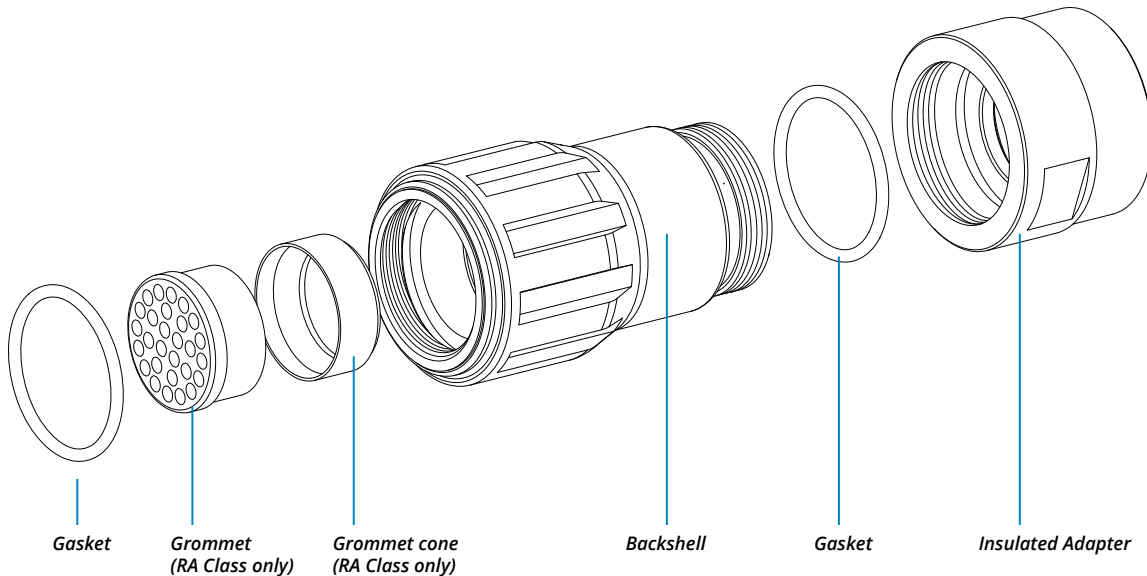

The accessories for this class are not always available in stock for all sizes; we suggest you consult our Sales Office for availability

RF	Insulating material	RF	Fire resistant rubber	X	Polarization Code**	Alternate Positions
CVBSG	Series Code	CVBSG	Bayonet Connector with external insulated coating	M12	Backshell internal thread	M Provided with an internal Metric thread PG Provided with an internal PG thread
[]	Shell Material	-	Aluminum	CR	Contact Termination	- Solder contacts CR Crimp contacts LC Less contacts
00	Shell Type	00	Front mounting Receptacle	CD5	Contact Plating	- Silver plating CD5 Gold plating
DA	Connector Class	DA	with waterproof O-ring (IP67***)	F7	Shell finish	F7 Black epoxy varnish (*) F16 CCF - Black passivation (*) - conductive F26 hard anodization (*)
T	Connector Modification**	T	With plastic caps	-	-	Without gasket G With waterproof panel gasket
20-4	Insert Arrangement	-	Receptacle connector with through holes	G	Panel Gasket	G2 With shielded panel gasket G3 With waterproof shielded panel gasket
S	Contact Gender	S	Size - Type	N	Modification Code**	N Consult our sales office S
		P	Socket contacts			
			Pin contacts			

*** Protection degree: IP 67 (only in the mating area with mated connectors) according to EN 60529 (*) RoHS compliance (**) If required

P/N Sample: RF CVBSG 00DAT 20-4SX M12 CR CD5 F7 G N

CVBSG - Bayonet Connector with external insulated coating

Rear Mounting Receptacle (030) with Backshell Class (DA...M - RA...M)

Connector with backshell provided with an internal Metric or PG thread suitable for Cable Glands or conduit adapters.

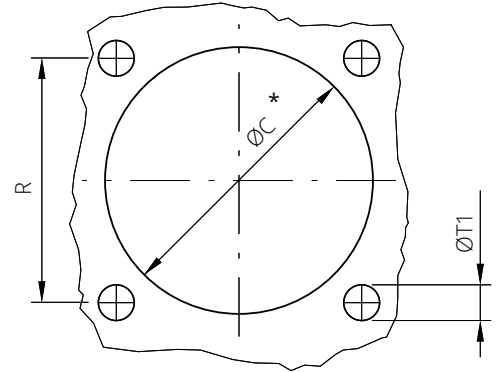

Panel cut out

* For installation with backshell mounted, consult our sales office.

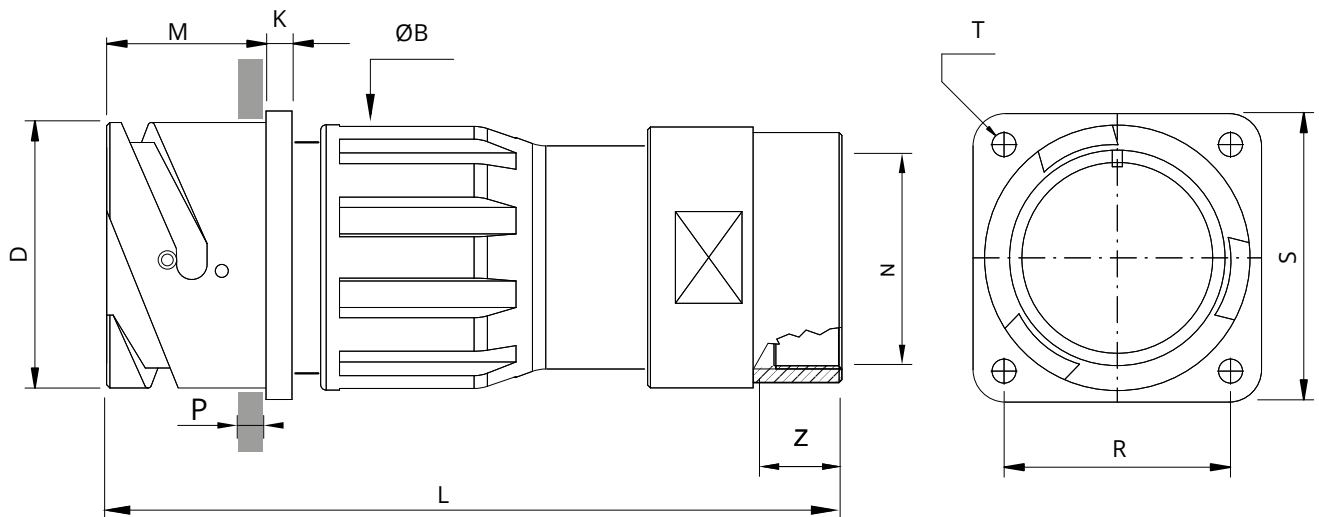

Shell size	ØD +0 -0.15	L max	M ±0.2	K ±0.2	ØB ±0.3	Z min	N Backshell Metric Thread	R ±0.1	S ±0.3	ØT	ØT1	P Panel Thickness Max	ØC* ±0.2
18	30.8	103	23.4	4	37	12	M20	27	34.9	M4	4.5	7.25	31.7
20	34.2	120	23.4	4	42	15	M25	29.4	38.1	M4	4.5	7.3	35
22	37.4	120	23.4	4	45	15	M25	31.8	41	M4	4.5	7.3	38.3
24	40.9	139	23.4	4	47.8	16	M32	34.9	44.5	M4	4.5	6.85	41.8
28	46.7	140	24.4	4	54.6	16	M32	39.7	50.8	M5	5.5	7.8	47.6
32	53.4	143	24.4	4	61.8	16	M32	44.5	57	M5	5.5	7.5	54.3
36	59.6	151	24.4	4	65.6	16	M32	49.2	63.5	M5	5.5	7.5	60.5
40	65.5	154	24.4	4	74	16	M32	55.6	69.8	M5	5.5	7.5	66.4

Dimensions in mm

Dimension "L" can be different from the value indicated according to backshells accessories, wires size and some special insert configurations.

CVBSG - Bayonet Connector with external insulated coating



Series Code **Shell Material** **Shell Type** **Connector Class**

Backshell internal thread

Shell finish

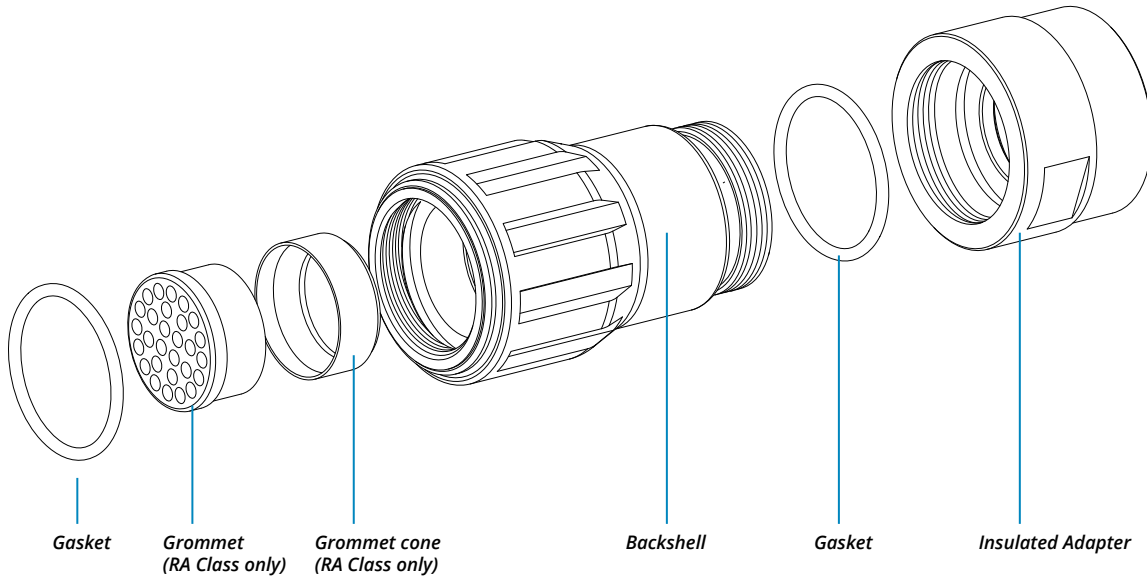

The accessories for this class are not always available in stock for all sizes; we suggest you consult our Sales Office for availability

RF	Insulating material	RF	Fire resistant rubber	X	Polarization Code**		Alternate Positions
CVBSG	Series Code	CVBSG	Bayonet Connector with external insulated coating	M12	Backshell internal thread	M	Provided with an internal Metric thread
	Shell Material	-	Aluminum			PG	Provided with an internal PG thread
030	Shell Type	030	Rear mounting Receptacle	CR	Contact Termination	-	Solder contacts
DA	Connector Class	DA	with waterproof O-ring (IP67***)			CR	Crimp contacts
		RA	with waterproof O-ring and grommet (IP67***)			LC	Less contacts
		T	With plastic caps	CD5	Contact Plating	-	Silver plating
T	Connector Modification**	-	Receptacle connector with threaded holes			F7	Black epoxy varnish (*)
		FP	Receptacle connector with through holes			F16	CCF - Black passivation (*) - conductive
20-4	Insert Arrangement		Size - Type			F26	hard anodization (*)
S	Contact Gender	S	Socket contacts	G	Panel Gasket	-	Without gasket
		P	Pin contacts			G	With waterproof panel gasket
						G2	With shielded panel gasket
						G3	With waterproof shielded panel gasket
				N	Modification Code**	N	Consult our sales office
						S	Consult our sales office

*** Protection degree: IP 67 (only in the mating area with mated connectors) according to EN 60529 (*) RoHS compliance (***) If required

P/N Sample: RF CVBSG 030DAT 20-4SX M12 CR CD5 F7 G N

CVBSG - Bayonet Connector with external insulated coating

Rear Mounting Receptacle (030) with Backshell Class (DA...FS - RA...FS)

Connector with special adapter for rubber conduits.

Conduit's size must be specified adding the diameter dimensions in the P/N (i.e.: CVBSG 030DA...FS5040...).

Rubber covered coupling nut able to protect against dust and impact.

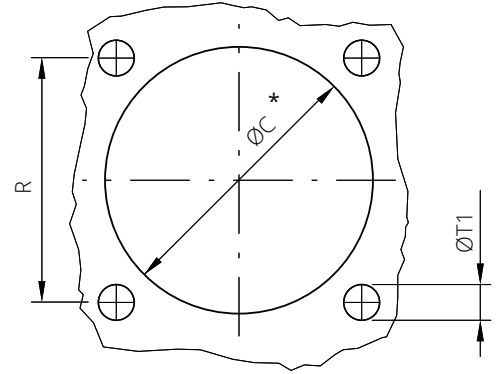

Panel cut out

* For installation with backshell mounted, consult our sales office.

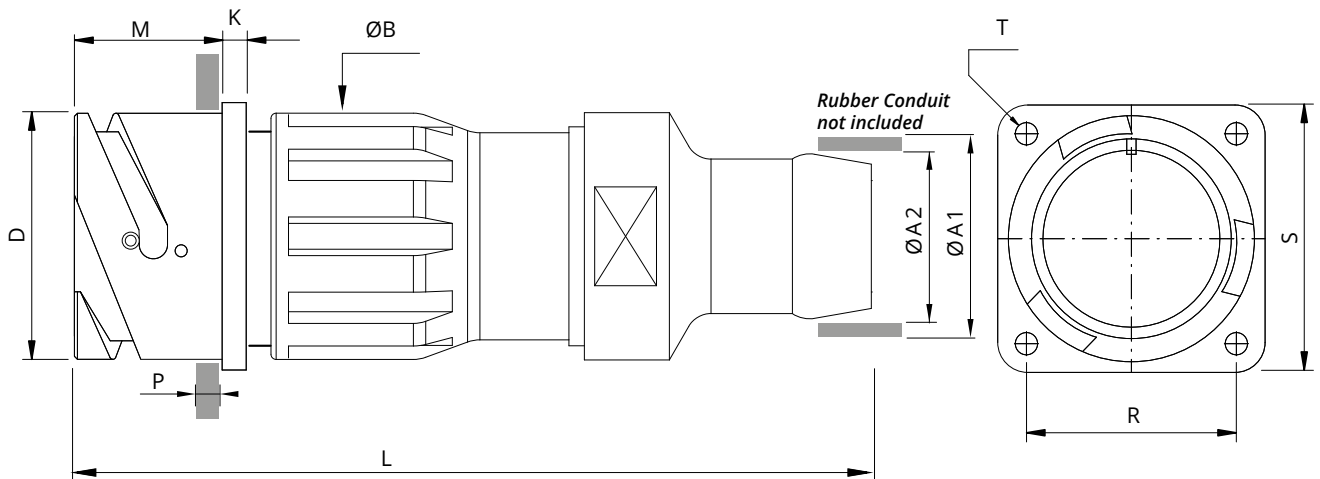

Shell size	ØD	L	M	K	ØB	R	S	ØT	ØT1	P	ØC*
	+0 -0.15	max	±0.2	±0.2	±0.3	±0.1	±0.3			Panel Thickness Max	±0.2
18	30.8	119	23.4	4	37	27	34.9	M4	4.5	7.25	31.7
20	34.2	132	23.4	4	42	29.4	38.1	M4	4.5	7.3	35
22	37.4	132	23.4	4	45	31.8	41	M4	4.5	7.3	38.3
24	40.9	150	23.4	4	47.8	34.9	44.5	M4	4.5	6.85	41.8
28	46.7	150	24.4	4	54.6	39.7	50.8	M5	5.5	7.8	47.6
32	53.4	150	24.4	4	61.8	44.5	57	M5	5.5	7.5	54.3
36	59.6	160	24.4	4	65.6	49.2	63.5	M5	5.5	7.5	60.5
40	65.5	165	24.4	4	74	55.6	69.8	M5	5.5	7.5	66.4

Backshell Conduit Size	ØA1	ØA2
FS1813	18	13
FS2015	20	15
FS2520	25	20
FS2722	27	22
FS3328	33	28
FS2924	29	24
FS3530	35	30
FS3833	38	33
FS4030	40	30
FS4035	40	35
FS4540	45	40
FS5040	50	40
FS5045	50	45
FS5247	52	47
FS5550	55	50

Dimensions in mm

Dimension "L" can be different from the value indicated according to backshells accessories, wires size and some special insert configurations.

CVBSG - Bayonet Connector with external insulated coating

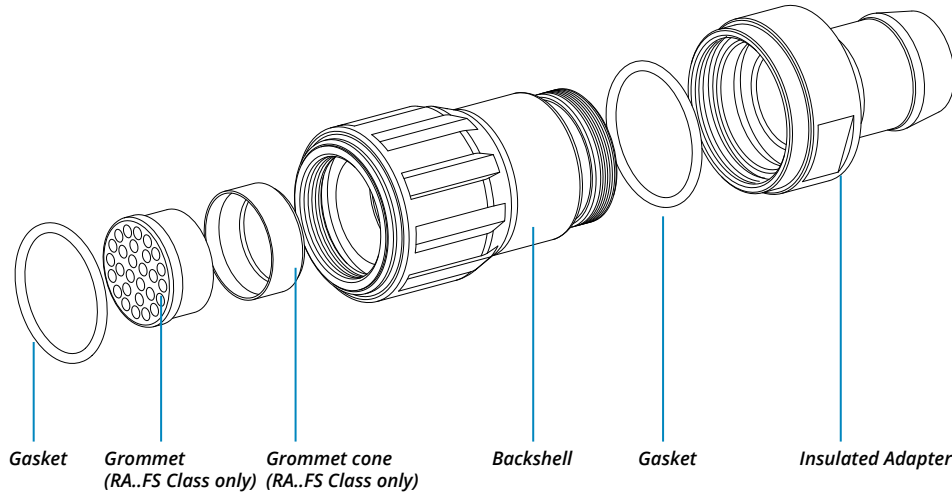

The accessories for this class are not always available in stock for all sizes; we suggest you consult our Sales Office for availability

RF	Insulating material	RF	Fire resistant rubber	X	Polarization Code**		Alternate Positions
CVBSG	Series Code	CVBSG	Bayonet Connector with external insulated coating	FS..	Backshell Conduits size	FS	Provided with a special adapter for rubber conduits
[]	Shell Material	-	Aluminum	xxxx	Conduit Size	xxxx	ØA1ØA2
030	Shell Type	030	Rear mounting Receptacle	CR	Contact Termination	-	Solder contacts
DA	Connector Class	DA	with waterproof O-ring (IP67***)	CR		CR	Crimp contacts
		RA	with waterproof O-ring and grommet (IP67***)	LC		LC	Less contacts
T	Connector Modification**	T	With plastic caps	CD5	Contact Plating	-	Silver plating
		-	Receptacle connector with threaded holes	F7	Shell finish	F7	Black epoxy varnish (*)
		FP	Receptacle connector with through holes			F16	CCF - Black passivation (*) - conductive
20-4	Insert Arrangement		Size - Type			F26	hard anodization (*)
S	Contact Gender	S	Socket contacts	G	Panel Gasket	-	Without gasket
		P	Pin contacts			G	With waterproof panel gasket
						G2	With shielded panel gasket
				N	Modification Code**	G3	With waterproof shielded panel gasket
						N	Consult our sales office
						S	

*** Protection degree: IP 67 (only in the mating area with mated connectors) according to EN 60529 (*) RoHS compliance (**) If required

P/N Sample: RF CVBSG 030DAT 20-4SX FS5040 CR CD5 F7 G N

CVBSG - Bayonet Connector with external insulated coating

Rear Mounting Receptacle (030) with Backshell Class (DA...MTG - RA...MTG)

Connector with a special adapter for clamping and retaining rubber conduits, with nut.
 Conduit's size must be specified adding the diameter dimensions in the P/N (i.e.: CVBSG 030DA...MTG2015...).
 Rubber covered coupling nut able to protect against dust and impact.

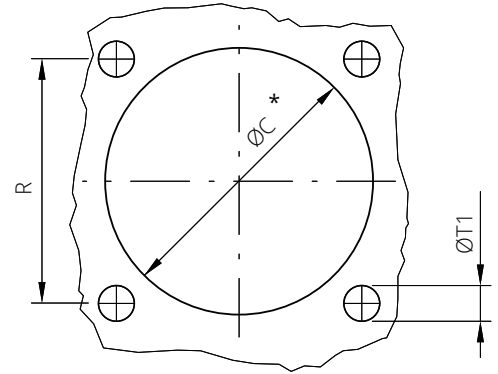

Panel cut out

* For installation with backshell mounted, consult our sales office.

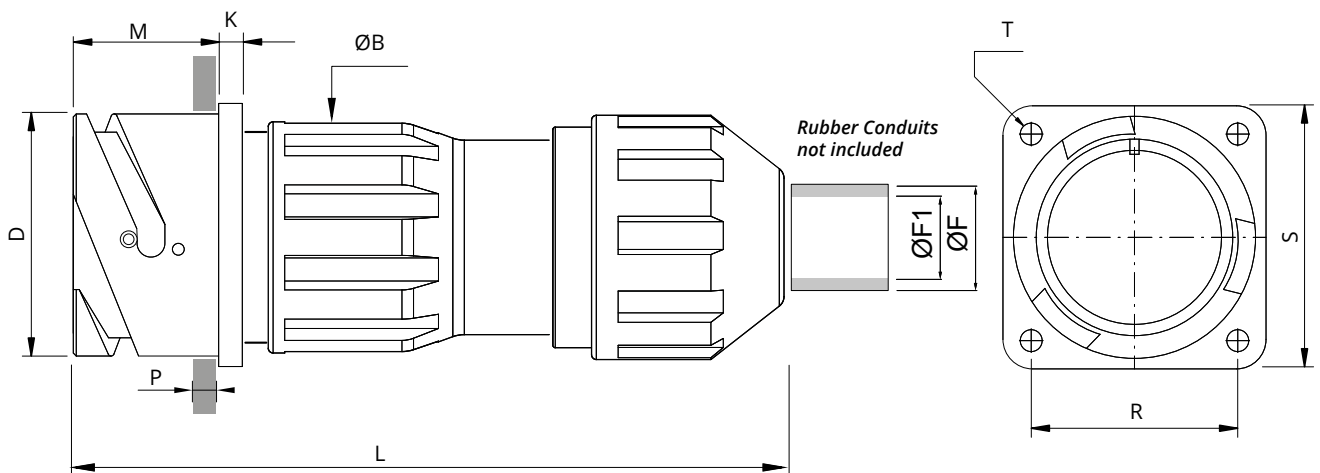

Shell size	ØD +0 -0.15	L max	M ±0.2	K ±0.2	ØB ±0.3	ØF	ØF1	Backshell Conduit Size**	R ±0.1	S ±0.3	ØT	ØT1	P Panel Thickness Max	ØC* ±0.2
18	30.8	106	23.4	4	37	17 20	12 15	MTG1712 MTG2015	27	34.9	M4	4.5	7.25	31.7
20	34.2	124	23.4	4	42	*	*	*	29.4	38.1	M4	4.5	7.3	35
22	37.4	124	23.4	4	45	32	27	MTG3227	31.8	41	M4	4.5	7.3	38.3
24	40.9	145	23.4	4	47.8	*	*	*	34.9	44.5	M4	4.5	6.85	41.8
28	46.7	145	24.4	4	54.6	29	24	MTG2924	39.7	50.8	M5	5.5	7.8	47.6
32	53.4	147	24.4	4	61.8	*	*	*	44.5	57	M5	5.5	7.5	54.3
36	59.6	155	24.4	4	65.6	*	*	*	49.2	63.5	M5	5.5	7.5	60.5
40	65.5	160	24.4	4	74	*	*	*	55.6	69.8	M5	5.5	7.5	66.4

Dimensions in mm

Dimension "L" can be different from the value indicated according to backshells accessories, wires size and some special insert configurations.

** Dimensions ØF1 and ØF2 are determined by conduit size.

*Please consult our Sales Office for further details.

CVBSG - Bayonet Connector with external insulated coating



Series Code

Shell Type

Connector Class

Backshell Conduits size

Shell finish

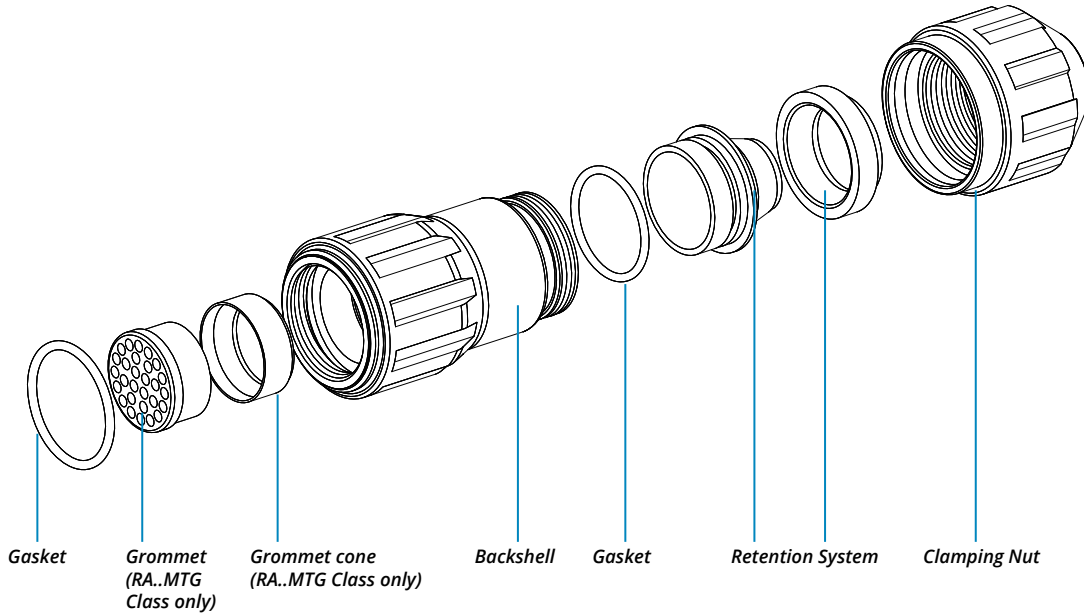

The accessories for this class are not always available in stock for all sizes; we suggest you consult our Sales Office for availability

RF	Insulating material	RF	Fire resistant rubber	X	Polarization Code**		Alternate Positions
CVBSG	Series Code	CVBSG	Bayonet Connector with external insulated coating	MTG	Backshell Conduits size	MTG	Provided with a special adapter for rubber conduits, with nut.
	Shell Material	-	Aluminum	2015	Conduit Size	xxxx	ØFØF1
030	Shell Type	030	Rear mounting Receptacle	CR	Contact Termination	-	Solder contacts
DA	Connector Class	DA	with waterproof O-ring (IP67***)	CR		CR	Crimp contacts
		RA	with waterproof O-ring and grommet (IP67***)	LC		LC	Less contacts
		T	With plastic caps	CD5	Contact Plating	-	Silver plating
T	Connector Modification**	-	Receptacle connector with threaded holes	F7	Shell finish	F7	Black epoxy varnish (*)
		FP	Receptacle connector with through holes			F16	CCF - Black passivation (*) - conductive
20-4	Insert Arrangement		Size - Type			F26	hard anodization (*)
S	Contact Gender	S	Socket contacts	G	Panel Gasket	-	Without gasket
		P	Pin contacts			G	With waterproof panel gasket
				G2		G2	With shielded panel gasket
				G3		G3	With waterproof shielded panel gasket
				N	Modification Code**	N	Consult our sales office
						S	Consult our sales office

*** Protection degree: IP 67 (only in the mating area with mated connectors) according to EN 60529 (*) RoHS compliance (**) If required

P/N Sample: RF CVBSG 030DAT 20-4SX MTG2015 CR CD5 F7 G N

CVBSG - Bayonet Connector with external insulated coating

Plug Connector (06) with Backshell Class (DAM - RAM)

Protected connector with rubber coated backshell and strain relief.
 Cable retention and watertightness are guaranteed by conical gasket and metal cone.
 Rubber covered coupling nut able to protect against dust and impact.

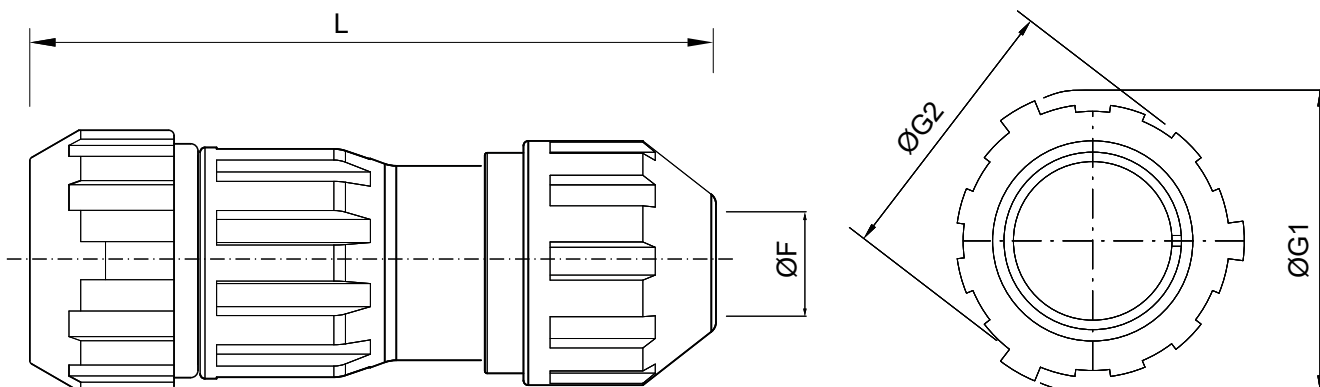

Shell size	ØG1	ØG2	L max	ØF	
				Min	Max
18	49	43.5	102	9.6	15.9
20	51.5	46	120	11.3	19
22	56	50.5	120	11.3	19
24	60	54	145	15.5	23.8
28	67	61	145	15.5	23.8
32	76	69	147	23.4	31.8
36	82	73.5	155	25.4	35
40	88	80	160	30	41.3

Dimensions in mm

Dimension "L" can be different from the value indicated according to backshells accessories, wires size and some special insert configurations.

CVBSG - Bayonet Connector with external insulated coating

RF	CVBSG		06	DAM	T	20-4	S	X	CR	CD5	F7		N
Series Code	Shell Material	Shell Type	Connector Class								Shell finish		

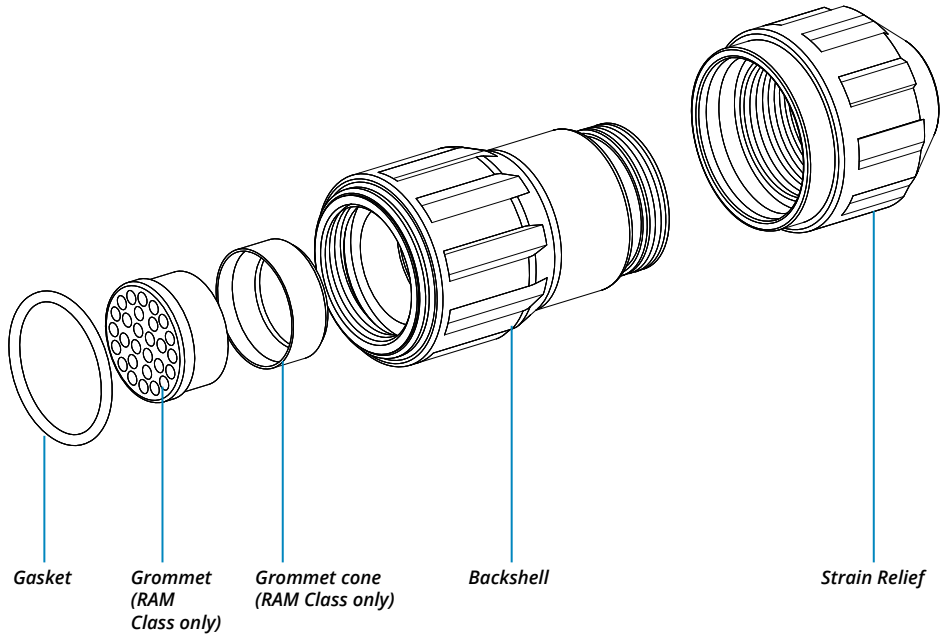

The accessories for this class are not always available in stock for all sizes; we suggest you consult our Sales Office for availability

RF	Insulating material	RF	Fire resistant rubber	S	Contact Gender	S	Socket contacts
CVBSG	Series Code	CVBSG	Bayonet Connector with external insulated coating	P		P	Pin contacts
	Shell Material	-	Aluminum	X	Polarization Code**		Alternate Positions
06	Shell Type	06	Plug Connector	CR	Contact Termination	-	Solder contacts
DAM	Connector Class	DAM	with waterproof O-ring (IP67***)	CR		CR	Crimp contacts
		RAM	with waterproof O-ring and grommet (IP67***)	LC		LC	Less contacts
T	Connector Modification**	T	With plastic caps	CD5	Contact Plating	-	Silver plating
20-4	Insert Arrangement		Size - Type	F7	Shell finish	CD5	Gold plating
				F7		F7	Black epoxy varnish (*)
				F16		F16	CCF - Black passivation (*) - conductive
				F26		F26	hard anodization (*)
				N	Modification Code**	N	Consult our sales office
				S		S	

*** Protection degree: IP 67 (only in the mating area with mated connectors) according to EN 60529 (*) RoHS compliance (***) If required

P/N Sample: RF CVBSG 06DAMT 20-4SX CR CD5 F7 N

CVBSG - Bayonet Connector with external insulated coating

Plug Connector (06) with Backshell Class (DA..M - RA..M)

Connector with backshell provided with an internal Metric or PG thread suitable for Cable Glands or conduit adapters. Rubber covered coupling nut able to protect against dust and impact.

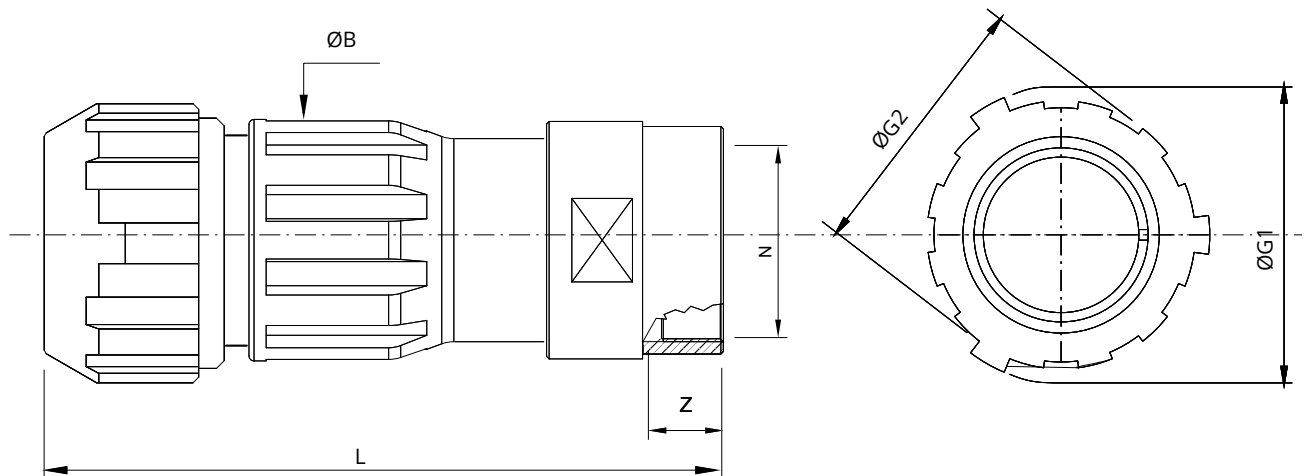

Shell size	ØG1	ØG2	L max	ØB ±0.3	Z min	N Backshell Metric Thread
18	49	43.5	99	37	12	M20
20	51.5	46	116	42	15	M25
22	56	50.5	116	45	15	M25
24	60	54	141	47.8	16	M32
28	67	61	141	54.6	16	M32
32	76	69	143	61.8	16	M32
36	82	73.5	151	65.6	16	M32
40	88	80	156	74	16	M32

Dimensions in mm

Dimension "L" can be different from the value indicated according to backshells accessories, wires size and some special insert configurations.

CVBSG - Bayonet Connector with external insulated coating



Series Code

Shell Type

Connector Class

Backshell internal thread

Shell finish

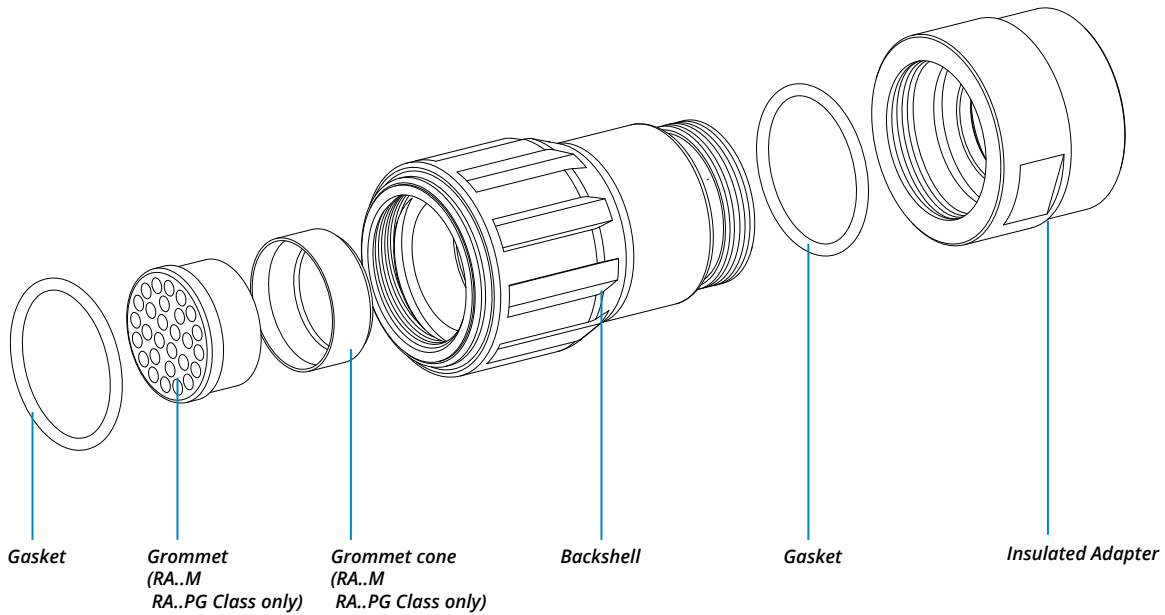

The accessories for this class are not always available in stock for all sizes; we suggest you consult our Sales Office for availability

RF	Insulating material	RF	Fire resistant rubber	S	Contact Gender	S	Socket contacts
CVBSG	Series Code	CVBSG	Bayonet Connector with external insulated coating	P		P	Pin contacts
	Shell Material	-	Aluminum	X	Polarization Code**		Alternate Positions
06	Shell Type	06	Plug Connector	M12	Backshell internal thread	M	Provided with an internal Metric thread
DA	Connector Class	DA	with waterproof O-ring (IP67***)	PG		PG	Provided with an internal PG thread
RA		RA	with waterproof O-ring and grommet (IP67***)	CR	Contact Termination	-	Solder contacts
T	Connector Modification**	T	With plastic caps	CR		CR	Crimp contacts
20-4	Insert Arrangement		Size - Type	LC		LC	Less contacts
				CD5	Contact Plating	-	Silver plating
				CD5		CD5	Gold plating
				F7	Shell finish	F7	Black epoxy varnish (*)
						F16	CCF - Black passivation (*) - conductive
						F26	hard anodization (*)
				N	Modification Code**	N	Consult our sales office
						S	

*** Protection degree: IP 67 (only in the mating area with mated connectors) according to EN 60529 (*) RoHS compliance (**) If required

P/N Sample: RF CVBSG 06DAT 20-4SX M12 CR CD5 F7 N

CVBSG - Bayonet Connector with external insulated coating

Plug Connector (06) with Backshell Class (DA..FS - RA..FS)

Connector with special adapter for rubber conduits.

Conduit's size must be specified adding the diameter dimensions in the P/N (i.e.: CVBSG 06DA...FS5040...).

Rubber covered coupling nut able to protect against dust and impact.

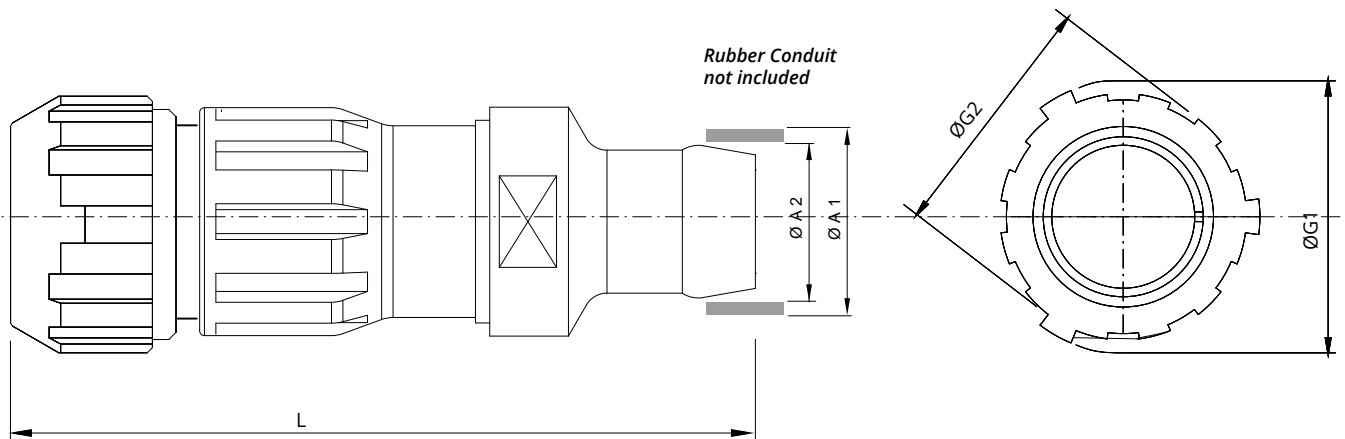

Please consult our Sales Office for further details about this dimension and according to conduit size.

Shell size	ØG1	ØG2	L max	ØB ±0.3
18	49	43.5	115	37
20	51.5	46	128	42
22	56	50.5	128	45
24	60	54	150	47.8
28	67	61	150	54.6
32	76	69	150	61.8
36	82	73.5	160	65.6
40	88	80	165	74

Backshell Conduit Size	ØA1	ØA2
FS1813	18	13
FS2015	20	15
FS2520	25	20
FS2722	27	22
FS3328	33	28
FS2924	29	24
FS3530	35	30
FS3833	38	33
FS4030	40	30
FS4035	40	35
FS4540	45	40
FS5040	50	40
FS5045	50	45
FS5247	52	47
FS5550	55	50

Dimensions in mm

Dimension "L" can be different from the value indicated according to backshells accessories, wires size and some special insert configurations.

CVBSG - Bayonet Connector with external insulated coating

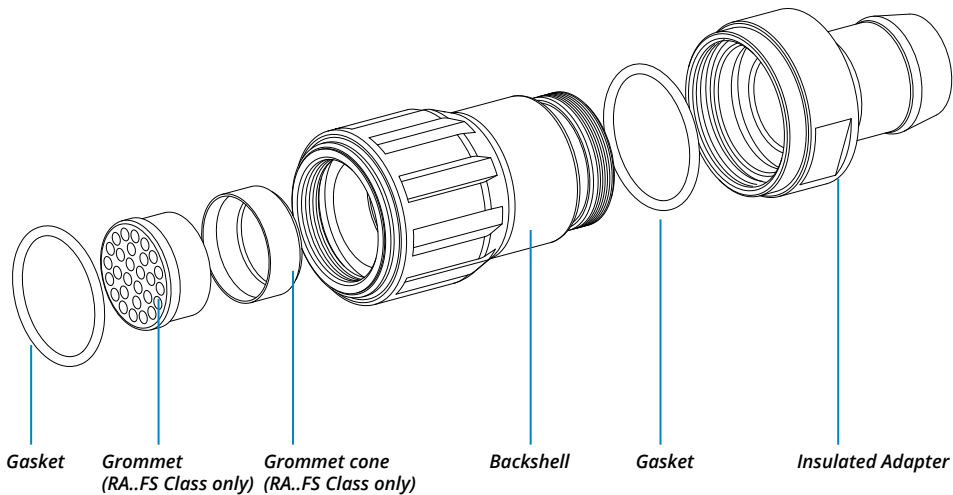

The accessories for this class are not always available in stock for all sizes; we suggest you consult our Sales Office for availability

RF	Insulating material	RF	Fire resistant rubber	X	Polarization Code**		Alternate Positions
CVBSG	Series Code	CVBSG	Bayonet Connector with external insulated coating	FS..	Backshell Conduits size or internal thread	FS	Provided with a special adapter for rubber conduits
	Shell Material	-	Aluminum	xxxx	Conduit Size	xxxx	ØA1ØA2
06	Shell Type	06	Plug Connector	CR	Contact Termination	-	Solder contacts
DA	Connector Class	DA	with waterproof O-ring (IP67***)	CR		CR	Crimp contacts
		RA	with waterproof O-ring and grommet (IP67***) #	LC		LC	Less contacts
T	Connector Modification**	T	With plastic caps	CD5	Contact Plating	-	Silver plating
20-4	Insert Arrangement		Size - Type	CD5		CD5	Gold plating
S	Contact Gender	S	Socket contacts	F7	Shell finish	F7	Black epoxy varnish (*)
		P	Pin contacts			F16	CCF - Black passivation (*) - conductive
				N	Modification Code**	N	Consult our sales office
						S	

*** Protection degree: IP 67 (only in the mating area with mated connectors) according to EN 60529 (*) RoHS compliance (**) If required

P/N Sample: RF CVBSG 06DAT 20-4SX FS5040 CR CD5 F7 N

CVBSG - Bayonet Connector with external insulated coating

Plug Connector (06) with Backshell Class (DA..MTG - RA..MTG)

Connector with a special adapter for clamping and retaining rubber conduits, with nut.
 Conduit's size must be specified adding the diameter dimensions in the P/N (i.e.: CVBSG 06DA...MTG2025...).
 Rubber covered coupling nut able to protect against dust and impact.

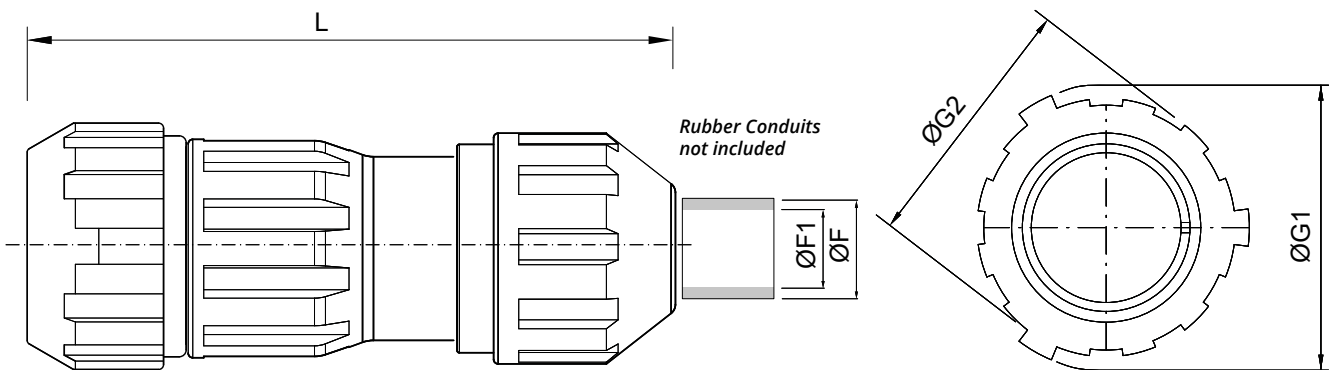

Shell size	ØG1	ØG2	L max	ØF	ØF1	Backshell Conduit Size**
18	49	43.5	102	17 20	12 15	MTG1712 MTG2015
20	51.5	46	120	*	*	*
22	56	50.5	120	32	27	MTG3227
24	60	54	145	*	*	*
28	67	61	145	29	24	MTG2924
32	76	69	147	*	*	*
36	82	73.5	155	*	*	*
40	88	80	160	*	*	*

** Dimensions ØF1 and ØF2 are determined by conduit size.

*Please consult our Sales Office for further details.

Dimensions in mm

Dimension "L" can be different from the value indicated according to backshells accessories, wires size and some special insert configurations.

CVBSG - Bayonet Connector with external insulated coating



Series Shell Code Material Type

Shell Connector Class

Backshell Conduits size

Conduit Size

Shell finish

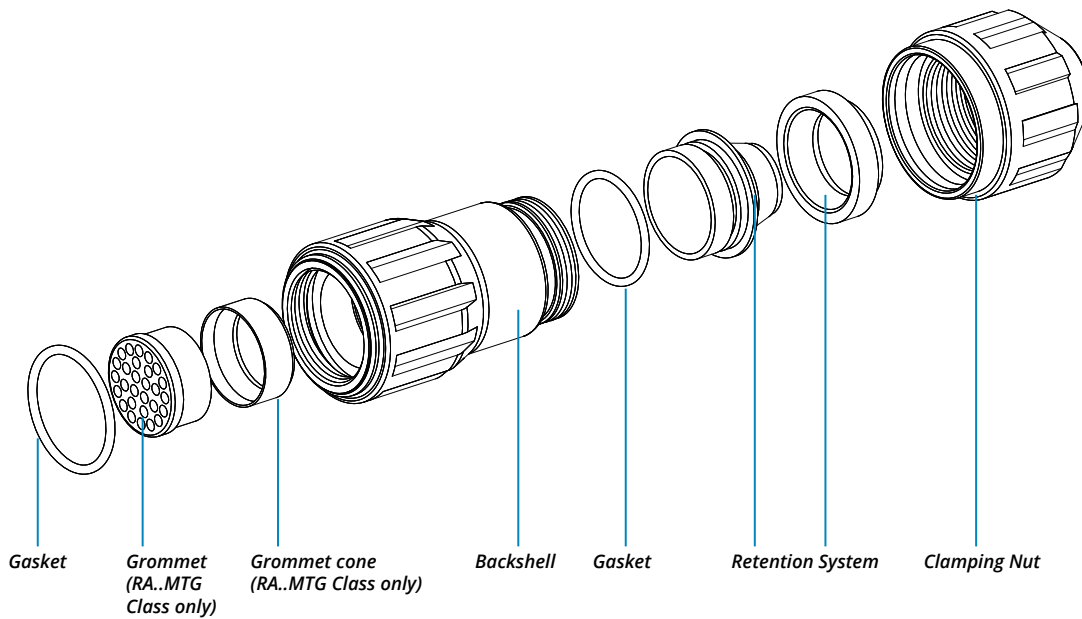

The accessories for this class are not always available in stock for all sizes; we suggest you consult our Sales Office for availability

RF	Insulating material	RF	Fire resistant rubber	X	Polarization Code**		Alternate Positions
CVBSG	Series Code	CVBSG	Bayonet Connector with external insulated coating	MTG	Backshell Conduits size	MTG	Provided with a special adapter for rubber conduits, with nut.
	Shell Material	-	Aluminum	2015	Conduit Size	xxxx	ØFØF1
06	Shell Type	06	Plug Connector	CR	Contact Termination	-	Solder contacts
DA	Connector Class	DA	with waterproof O-ring (IP67***)	CR		CR	Crimp contacts
		RA	with waterproof O-ring and grommet (IP67***) #	LC		LC	Less contacts
T	Connector Modification**	T	With plastic caps	CD5	Contact Plating	-	Silver plating
20-4	Insert Arrangement		Size - Type	CD5		CD5	Gold plating
S	Contact Gender	S	Socket contacts	F7	Shell finish	F7	Black epoxy varnish (*)
		P	Pin contacts			F16	CCF - Black passivation (*) - conductive
				N	Modification Code**	N	hard anodization (*)
						S	Consult our sales office

*** Protection degree: IP 67 (only in the mating area with mated connectors) according to EN 60529 (*) RoHS compliance (***) If required

P/N Sample: RF CVBSG 06DAT 20-4SX MTG2015 CR CD5 F7 N

CVBSG - Bayonet Connector with external insulated coating

Plug Connector (06) with Backshell Class (AMK - MK)

Connectors provided with gasket and iris spring connected to one another by an internal ring. The iris spring is used to connect multicore jacketed cables or jacketed hoses. An additional gasket added outside of the central body guarantees the complete watertightness. Clamping range on the dimension table has to be chosen according to the cable size and its shielding. Rubber covered coupling nut able to protect against dust and impact.

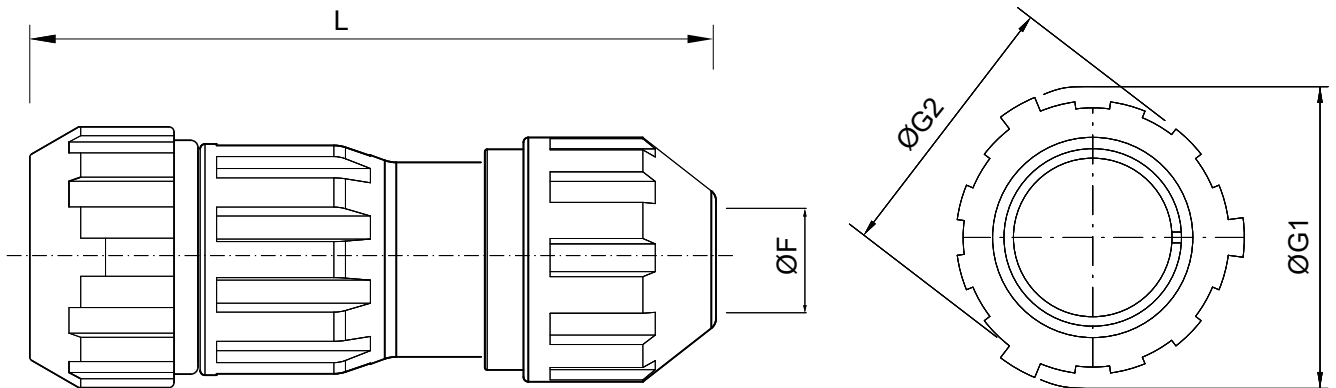

Shell size	ØG1	ØG2	L	ØF Clamping Range **	
				Min	Max
18	49	43.5	102	13	16
20	51.5	46	120	16	19
22	56	50.5	120	16	19
24	60	54	145	19	22
28	67	61	145	22	25
32	76	69	147	28	31
36	82	73.5	155	32	35
40	88	80	160	38	41

Dimensions in mm

Dimension "L" can be different from the value indicated according to backshells accessories, wires size and some special insert configurations.

** Clamping range to be verified with cable section. Please consult our Sales Office.

CVBSG - Bayonet Connector with external insulated coating



Series Code

Shell Type

Connector Class

Shell finish

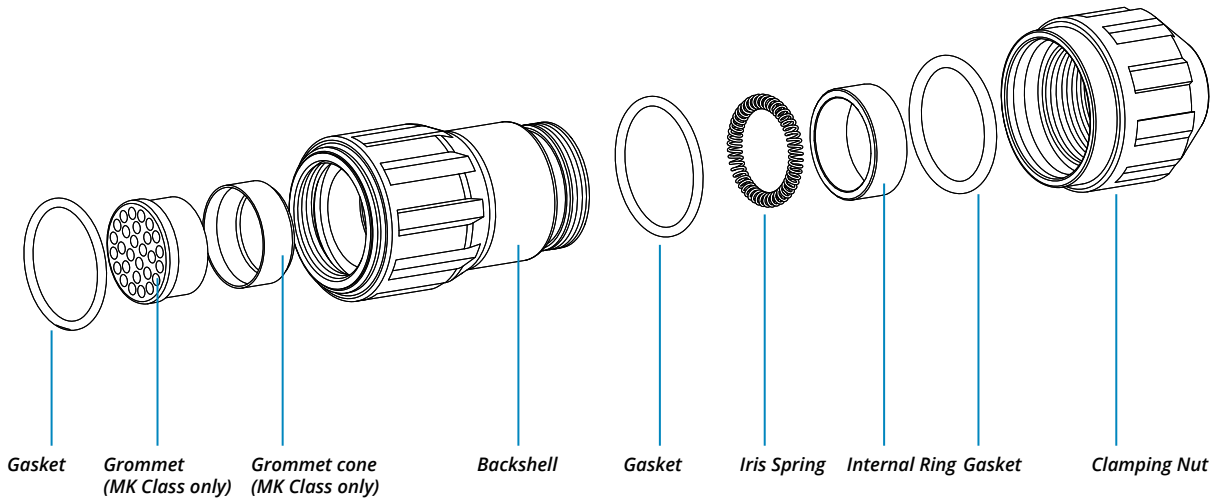

The accessories for this class are not always available in stock for all sizes; we suggest you consult our Sales Office for availability

RF	Insulating material	RF	Fire resistant rubber	S	Contact Gender	S	Socket contacts
CVBSG	Series Code	CVBSG	Bayonet Connector with external insulated coating	P		P	Pin contacts
	Shell Material	-	Aluminum	X	Polarization Code**		Alternate Positions
06	Shell Type	06	Plug Connector	CR	Contact Termination	-	Solder contacts
MK	Connector Class	AMK	with waterproof O-ring (IP67***)	CR		CR	Crimp contacts
		MK	With waterproof O-ring and grommet (IP67***)#	LC		LC	Less contacts
T	Connector Modification**	T	With plastic caps	CD5	Contact Plating	-	Silver plating
20-4	Insert Arrangement		Size - Type	F7	Shell finish	F7	Black epoxy varnish (*)
				F16		F16	CCF - Black passivation (*) - conductive
				F26		F26	hard anodization (*)
				N	Modification Code**	N	Consult our sales office
				S		S	

*** Protection degree: IP 67 (only in the mating area with mated connectors) according to EN 60529 (*) RoHS compliance (***) If required

P/N Sample: RF CVBS 06MKT 20-4SX CR CD5 F7 N

CVBSG - Bayonet Connector with external insulated coating

Plug Connector (96) with Backshell Class (AMK - MK)

Connector provided with grounding finger to guarantee shielding;

Connectors provided with gasket and iris spring connected to one another by an internal ring. The iris spring is used to connect multicore jacketed cables or jacketed hoses. An additional gasket added outside of the central body guarantees the complete watertightness. Clamping range on the dimension table has to be chosen according to the cable size and its shielding. Rubber covered coupling nut able to protect against dust and impact.



Grounding finger

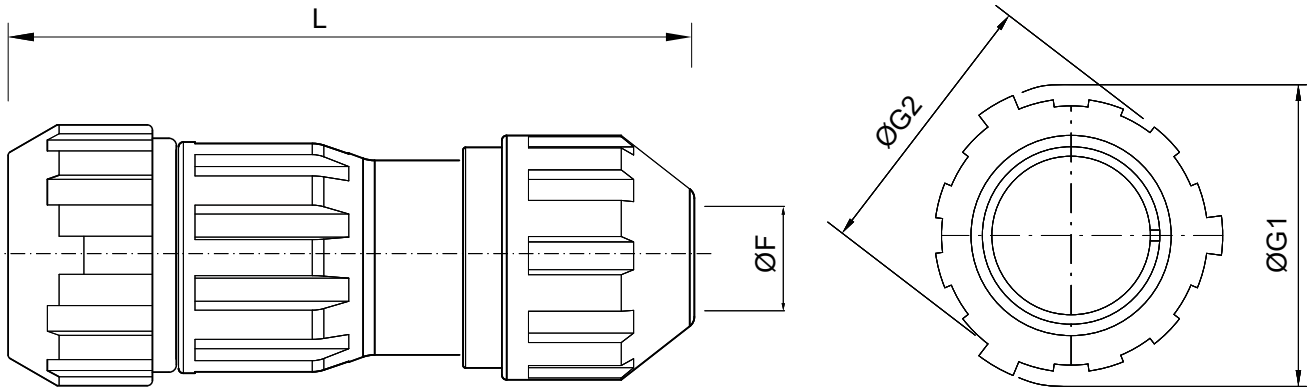
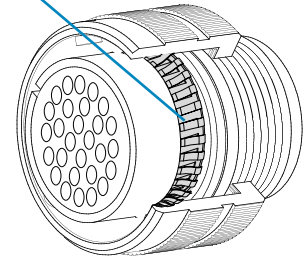

Shell size	ØG1	ØG2	L	ØF Clamping Range **	
				Min	Max
18	49	43.5	102	13	16
20	51.5	46	120	16	19
22	56	50.5	120	16	19
24	60	54	145	19	22
28	67	61	145	22	25
32	76	69	147	28	31
36	82	73.5	155	32	35
40	88	80	160	38	41

Dimensions in mm

Dimension "L" can be different from the value indicated according to backshells accessories, wires size and some special insert configurations.

** Clamping range to be verified with cable section. Please consult our Sales Office.

CVBSG - Bayonet Connector with external insulated coating



Series Code

Shell Type

Connector Class

Shell finish

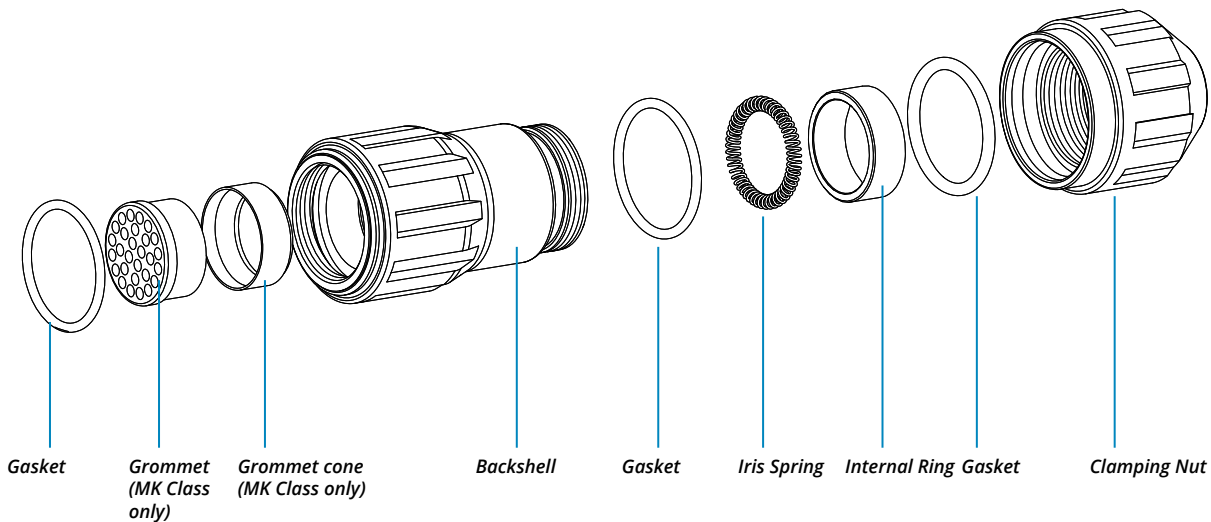

The accessories for this class are not always available in stock for all sizes; we suggest you consult our Sales Office for availability

RF	Insulating material	RF	Fire resistant rubber
CVBSG	Series Code	CVBSG	Bayonet Connector with external insulated coating
	Shell Material	-	Aluminum
96	Shell Type	06	Plug Connector with grounding finger
MK	Connector Class	AMK	with waterproof O-ring (IP67***)
		MK	With waterproof O-ring and grommet (IP67***)#
T	Connector Modification**	T	With plastic caps
20-4	Insert Arrangement		Size - Type

S	Contact Gender	S	Socket contacts
		P	Pin contacts
X	Polarization Code**		Alternate Positions
CR	Contact Termination	-	Solder contacts
		CR	Crimp contacts
		LC	Less contacts
CD5	Contact Plating	-	Silver plating
		CD5	Gold plating
F7	Shell finish	F7	Black epoxy varnish (*)
		F16	CCF - Black passivation (*) - conductive
		F26	hard anodization (*)
N	Modification Code**	N	Consult our sales office
		S	

*** Protection degree: IP 67 (only in the mating area with mated connectors) according to EN 60529 (*) RoHS compliance (**) If required

P/N Sample: RF CVBS 96MKT 20-4SX CR CD5 F7 N

CVBSG - Bayonet Connector with external insulated coating

Plug Connector (08) with 90° Elbow Class (DAM - RAM)

Protected connector with rubber coated backshell and strain relief.
Cable retention and watertightness are guaranteed by conical gasket and metal cone.
Rubber covered coupling nut able to protect against dust and impact.

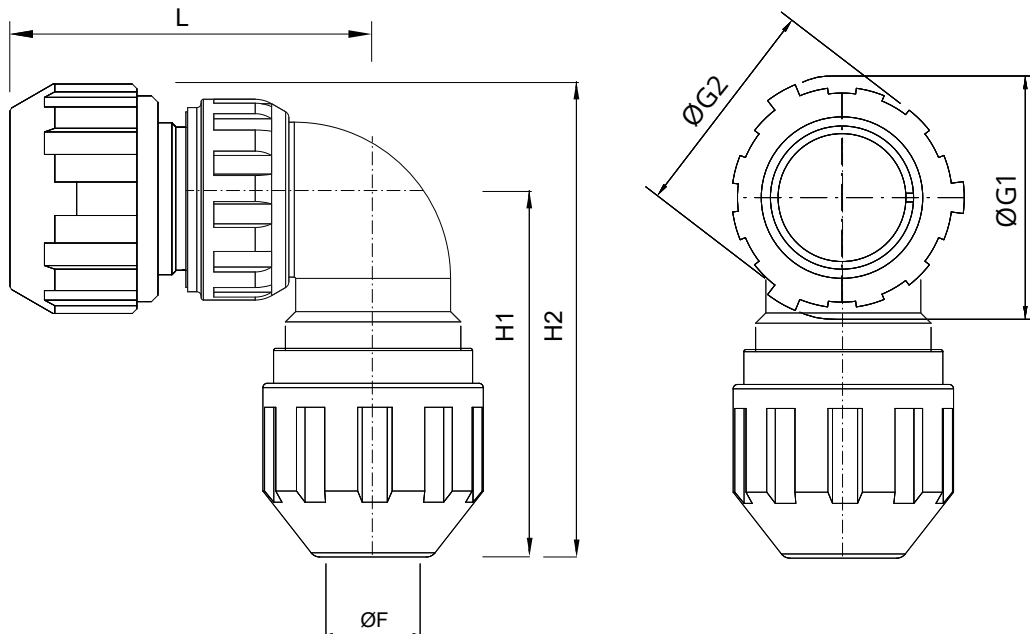

Shell size	ØG1	ØG2	L max	H1 max	H2 max	ØF	
						Min	Max
18	49	43.5	68	66	90.5	9.6	15.9
20	51.5	46	71	68	93.8	11.3	19
22	56	50.5	71	76	104	11.3	19
24	60	54	76	83	113	15.5	23.8
28	67	61	76	84	117.5	15.5	23.8
32	76	69	80	88	126	23.4	31.8
36	82	73.5	84	96	137	25.4	35
40	88	80	88	98	142	30	41.3

Dimensions in mm

Dimension "L" can be different from the value indicated according to backshells accessories, wires size and some special insert configurations.

CVBSG - Bayonet Connector with external insulated coating

RF	CVBSG		08	DAM	T	20-4	S	X	CR	CD5	F7		N
Series Code	Series Code	Shell Material	Shell Type	Connector Class	Connector Modification**	Insert Arrangement	Contact Gender	Polarization Code**	Contact Termination	Contact Plating	Shell finish	Modification Code**	

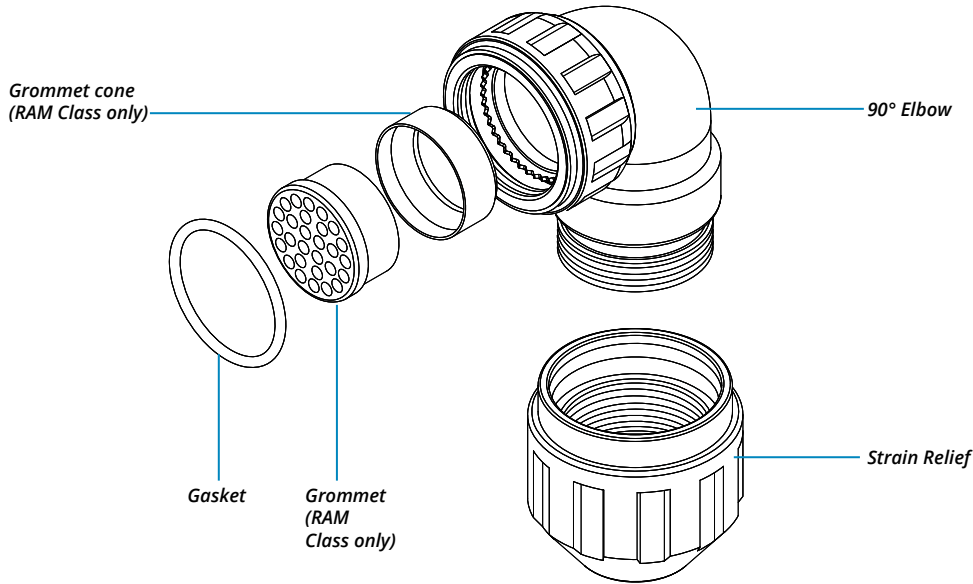

The accessories for this class are not always available in stock for all sizes; we suggest you consult our Sales Office for availability

RF	Insulating material	RF	Fire resistant rubber	S	Contact Gender	S	Socket contacts
CVBSG	Series Code	CVBSG	Bayonet Connector with external insulated coating	P		P	Pin contacts
	Shell Material	-	Aluminum	X	Polarization Code**		Alternate Positions
08	Shell Type	08	Plug Connector with 90° elbow	CR	Contact Termination	-	Solder contacts
DAM	Connector Class	DAM	with waterproof O-ring (IP67***)	CR		CR	Crimp contacts
		RAM	with waterproof O-ring and grommet (IP67***) #	LC		LC	Less contacts
T	Connector Modification**	T	With plastic caps	CD5	Contact Plating	-	Silver plating
20-4	Insert Arrangement		Size - Type	F7	Shell finish	CD5	Gold plating
				N	Modification Code**	F7	Black epoxy varnish (*)
				S		F16	CCF - Black passivation (*) - conductive
						N	Consult our sales office
						S	Consult our sales office

*** Protection degree: IP 67 (only in the mating area with mated connectors) according to EN 60529 (*) RoHS compliance (**) If required

P/N Sample: RF CVBSG 08DAMT 20-4SX CR CD5 F7 N

(#) In some sizes the grommet cone is not needed

CVBSG - Bayonet Connector with external insulated coating

Plug Connector (08) with 90° Elbow Class (DA..M - RA..M)

Connector with backshell provided with an internal Metric or PG thread suitable for Cable Glands or conduit adapters. Rubber covered coupling nut able to protect against dust and impact.

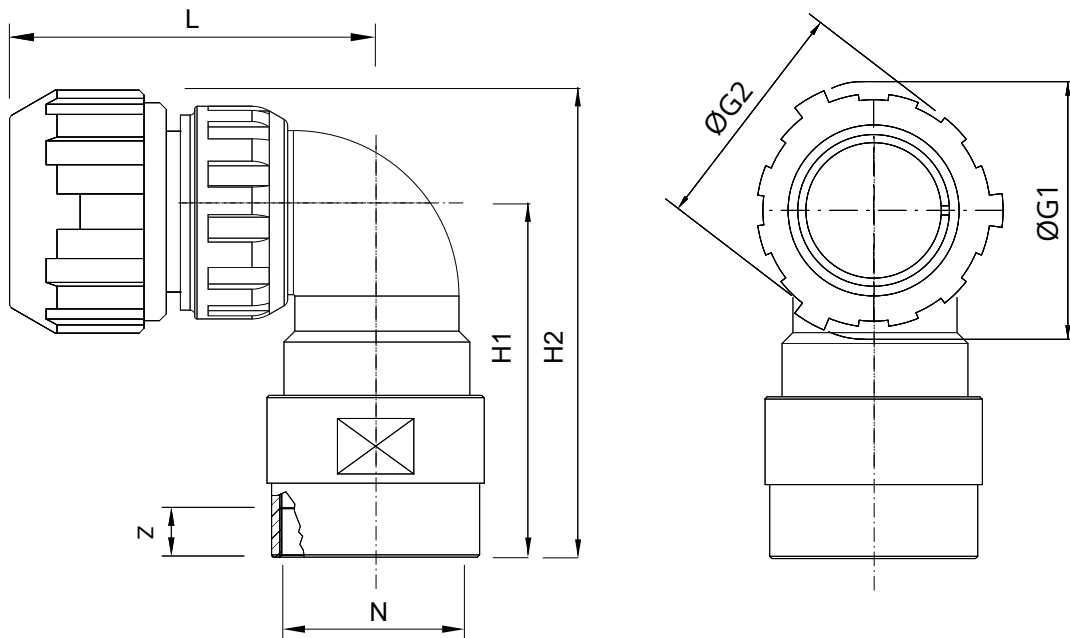

Shell size	ØG1	ØG2	L max	H1	H2	Z min	N Backshell Metric Thread
18	49	43.5	68	65	89.5	12	M20
20	51.5	46	71	67	92.8	15	M25
22	56	50.5	71	73	101	15	M25
24	60	54	76	80	110	16	M32
28	67	61	76	82	115.5	16	M32
32	76	69	80	84	122	16	M32
36	82	73.5	84	92	133	16	M32
40	88	80	88	94	138	16	M32

Dimensions in mm

Dimension "L" can be different from the value indicated according to backshells accessories, wires size and some special insert configurations.

CVBSG - Bayonet Connector with external insulated coating



Series Code

Shell Type

Connector Class

Backshell internal thread

Shell finish

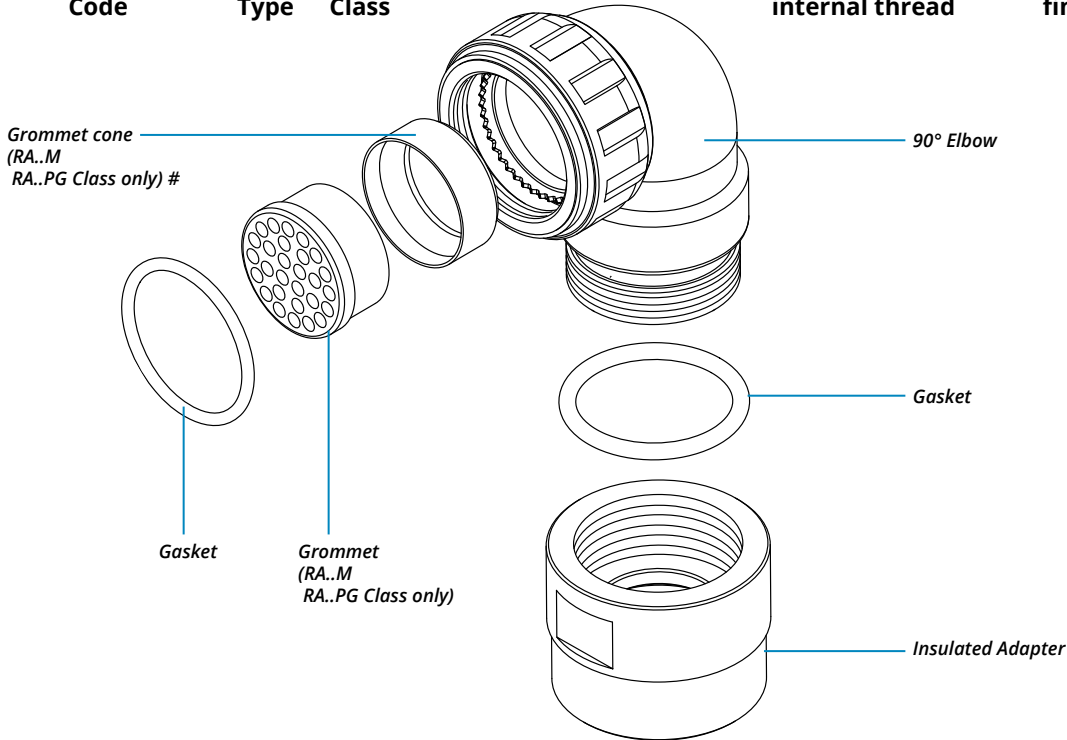

The accessories for this class are not always available in stock for all sizes; we suggest you consult our Sales Office for availability

RF	Insulating material	RF	Fire resistant rubber	S	Contact Gender	S	Socket contacts
						P	Pin contacts
CVBSG	Series Code	CVBSG	Bayonet Connector with external insulated coating	X	Polarization Code**		Alternate Positions
[]	Shell Material	-	Aluminum	M12	Backshell internal thread	M	Provided with an internal Metric thread
						PG	Provided with an internal PG thread
08	Shell Type	08	Plug Connector with 90° elbow	CR	Contact Termination	-	Solder contacts
						CR	Crimp contacts
DA	Connector Class	DA	with waterproof O-ring (IP67***)			LC	Less contacts
		RA	with waterproof O-ring and grommet (IP67***) #	CD5	Contact Plating	-	Silver plating
						CD5	Gold plating
T	Connector Modification**	T	With plastic caps	F7	Shell finish	F7	Black epoxy varnish (*)
						F16	CCF - Black passivation (*) - conductive
20-4	Insert Arrangement		Size - Type	N	Modification Code**	N	Consult our sales office
						S	

*** Protection degree: IP 67 (only in the mating area with mated connectors) according to EN 60529 (*) RoHS compliance (**) If required

P/N Sample: RF CVBSG 08DAT 20-4SX M12 CR CD5 F7 N

(#) In some sizes the grommet cone is not needed

CVBSG - Bayonet Connector with external insulated coating

Plug Connector (08) with 90° Elbow Class (DA..FS - RA..FS)

Connector with special adapter for rubber conduits.
 Conduit's size must be specified adding the diameter dimensions in the P/N (i.e.: CVBSG 08DA...FS5040...).
 Rubber covered coupling nut able to protect against dust and impact.



CVBSG SHELL

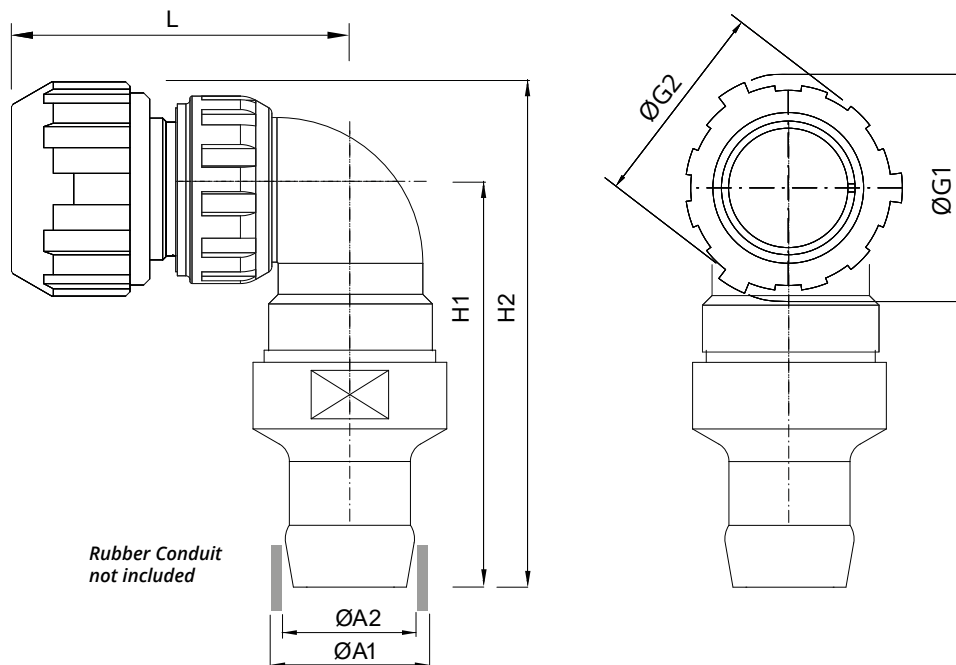

Please consult our Sales Office for further details about this dimension and according to conduit size.

Shell size	ØG1	ØG2	L max	H1	H2
18	49	43.5	68	85	109.5
20	51.5	46	71	85	110.8
22	56	50.5	71	85	113
24	60	54	76	85	115
28	67	61	76	85	118.5
32	76	69	80	85	123
36	82	73.5	84	90	131
40	88	80	88	95	139

Dimensions in mm

Dimension "L" can be different from the value indicated according to backshells accessories, wires size and some special insert configurations.

Backshell Conduit Size	ØA1	ØA2
FS1813	18	13
FS2015	20	15
FS2520	25	20
FS2722	27	22
FS3328	33	28
FS2924	29	24
FS3530	35	30
FS3833	38	33
FS4030	40	30
FS4035	40	35
FS4540	45	40
FS5040	50	40
FS5045	50	45
FS5247	52	47
FS5550	55	50

CVBSG - Bayonet Connector with external insulated coating



Series Code
CVBSG

Shell Type
08

Connector Class
DA

Backshell Conduits size
FS

Shell finish
F7

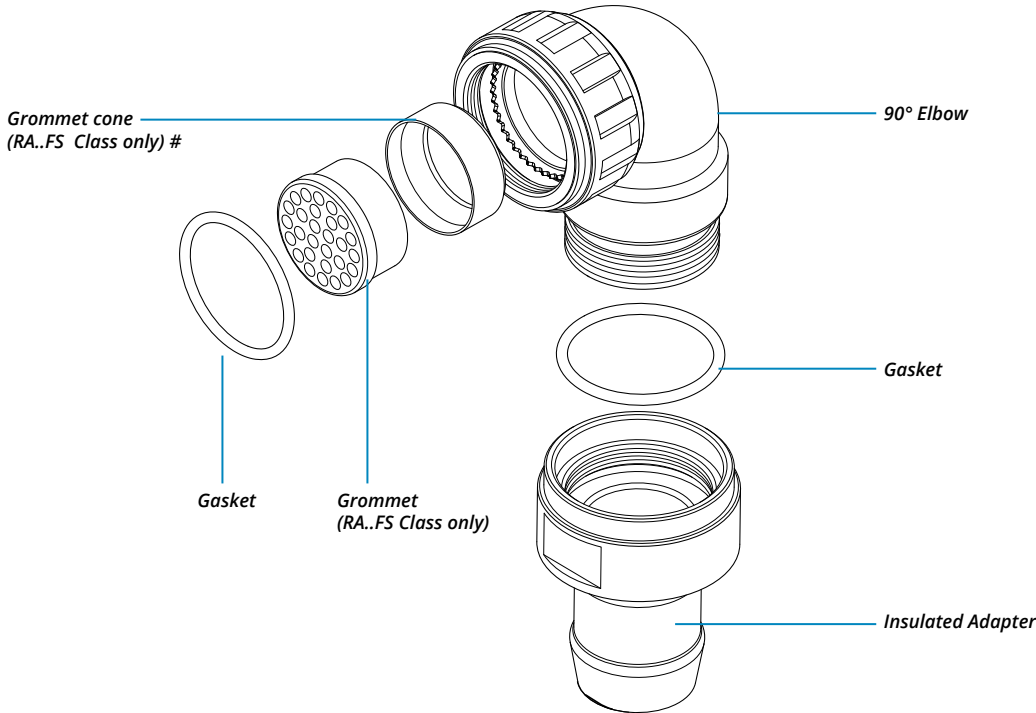

The accessories for this class are not always available in stock for all sizes; we suggest you consult our Sales Office for availability

RF	Insulating material	RF	Fire resistant rubber	X	Polarization Code**		Alternate Positions
CVBSG	Series Code	CVBSG	Bayonet Connector with external insulated coating	FS..	Backshell Conduits size	FS	Provided with a special adapter for rubber conduits
	Shell Material	-	Aluminum	xxxx	Conduit Size	xxxx	ØA1ØA2
08	Shell Type	08	Plug Connector with 90° elbow	CR	Contact Termination	-	Solder contacts
				CR		CR	Crimp contacts
				LC		LC	Less contacts
DA	Connector Class	DA	with waterproof O-ring (IP67***)	CD5	Contact Plating	-	Silver plating
		RA	with waterproof O-ring and grommet (IP67***) #	CD5		CD5	Gold plating
T	Connector Modification**	T	With plastic caps	F7	Shell finish	F7	Black epoxy varnish (*)
				F7		F16	CCF - Black passivation (*) - conductive
20-4	Insert Arrangement		Size - Type	N	Modification Code**	N	Consult our sales office
				N		S	
S	Contact Gender	S	Socket contacts				
		P	Pin contacts				

*** Protection degree: IP 67 (only in the mating area with mated connectors) according to EN 60529 (*) RoHS compliance (**) If required

P/N Sample: RF CVBSG 08DAT 20-4SX FS5040 CR CD5 F7 N

(#) In some sizes the grommet cone is not needed

CVBSG - Bayonet Connector with external insulated coating

Plug Connector (08) with 90° Elbow Class (DA..MTG - RA..MTG)

Connector with a special adapter for clamping and retaining rubber conduits, with nut.
 Conduit's size must be specified adding the diameter dimensions in the P/N (i.e.: CVBSG 08DA...MTG2025...).
 Rubber covered coupling nut able to protect against dust and impact.

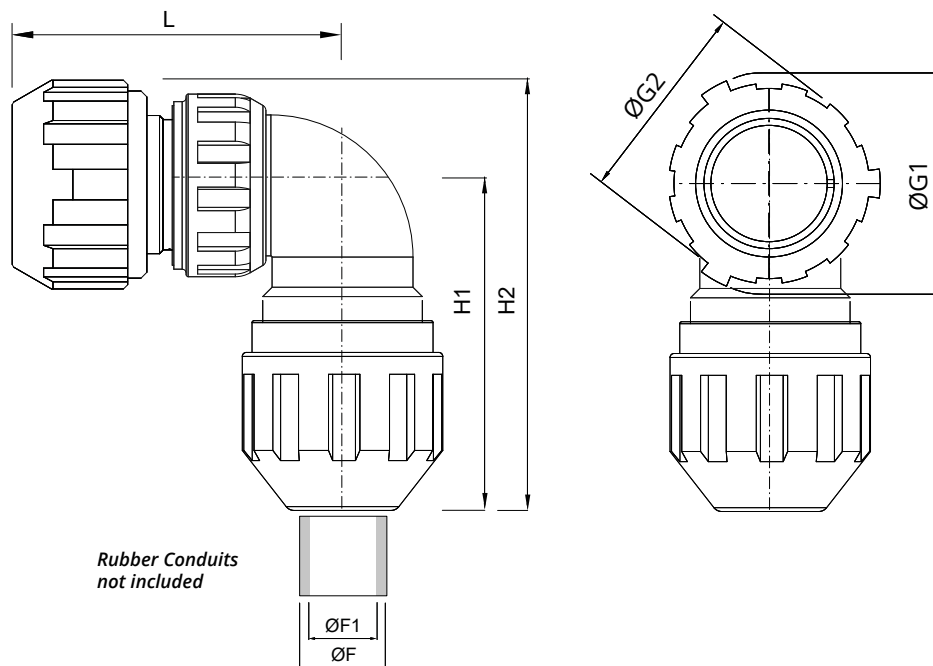

Shell size	ØG1	ØG2	L max	H1 max	H2 max	ØF	ØF1	Backshell Conduit Size**
18	49	43.5	68	66	90.5	17 20	12 15	MTG1712 MTG2015
20	51.5	46	71	68	93.8	*	*	*
22	56	50.5	71	76	104	32	27	MTG3227
24	60	54	76	83	113	*	*	*
28	67	61	76	84	117.5	29	24	MTG2924
32	76	69	80	88	126	*	*	*
36	82	73.5	84	96	137	*	*	*
40	88	80	88	98	142	*	*	*

** Dimensions ØF1 and ØF2 are determined by conduit size.

*Please consult our Sales Office for further details.

Dimensions in mm

Dimension "L" can be different from the value indicated according to backshells accessories, wires size and some special insert configurations.

CVBSG - Bayonet Connector with external insulated coating



Series Code: RF Shell Material: CVBSG Shell Type: 08 Connector Class: DA Modification: T Insert Arrangement: 20-4 Contact Gender: S Polarization: X Backshell Conduits size: MTG Conduit Size: 2015 Contact Termination: CR Contact Plating: CD5 Shell finish: F7 Modification Code: N

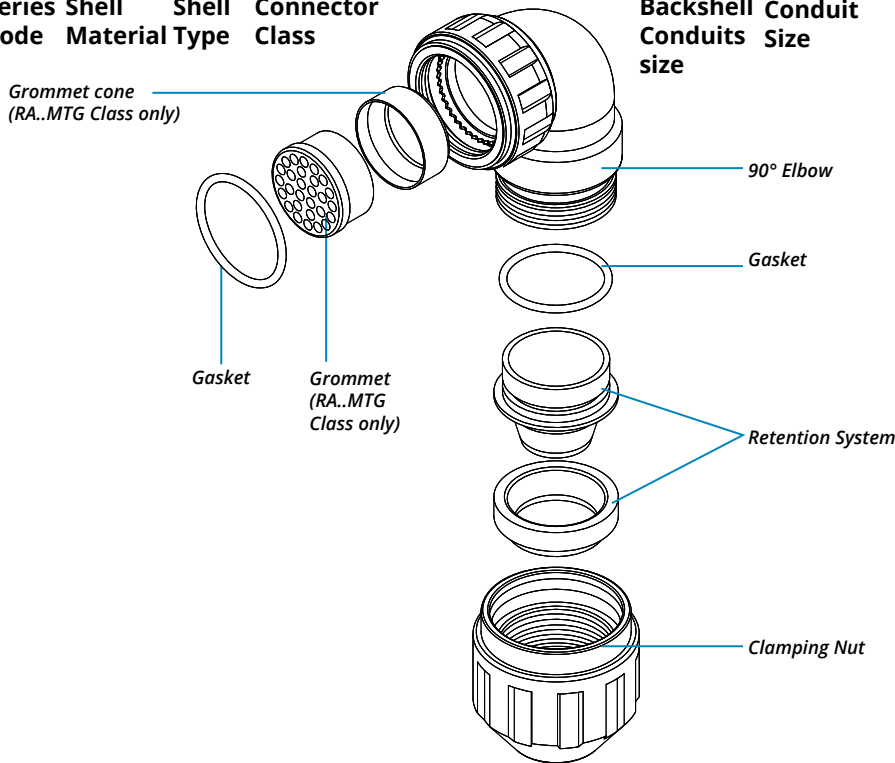

The accessories for this class are not always available in stock for all sizes; we suggest you consult our Sales Office for availability

RF	Insulating material	RF	Fire resistant rubber	X	Polarization Code**		Alternate Positions
CVBSG	Series Code	CVBSG	Bayonet Connector with external insulated coating	MTG	Backshell Conduits size	MTG	Provided with a special adapter for rubber conduits, with nut.
	Shell Material	-	Aluminum	2015	Conduit Size	xxxx	ØFØF1
08	Shell Type	08	Plug Connector with 90° elbow	CR	Contact Termination	-	Solder contacts
				CR		CR	Crimp contacts
				LC		LC	Less contacts
DA	Connector Class	DA	with waterproof O-ring (IP67***)	CD5	Contact Plating	-	Silver plating
		RA	with waterproof O-ring and grommet (IP67***) #	CD5		CD5	Gold plating
T	Connector Modification**	T	With plastic caps	F7	Shell finish	F7	Black epoxy varnish (*)
				F16		F16	CCF - Black passivation (*) - conductive
20-4	Insert Arrangement		Size - Type	N	Modification Code**	N	Consult our sales office
				S		S	
S	Contact Gender	S	Socket contacts				
		P	Pin contacts				

*** Protection degree: IP 67 (only in the mating area with mated connectors) according to EN 60529 (*) RoHS compliance (**) If required

P/N Sample: RF CVBSG 08DAT 20-4SX MTG2015 CR CD5 F7 N

(#) In some sizes the grommet cone is not needed

CVBSG - Bayonet Connector with external insulated coating

Plug Connector with rubber covered coupling nut (short version) (61) with Backshell Class (DAM - RAM)

Protected connector with rubber coated backshell and strain relief.
 Cable retention and watertightness are guaranteed by conical gasket and metal cone.
 Rubber covered coupling nut (short version) able to protect against dust and impact.

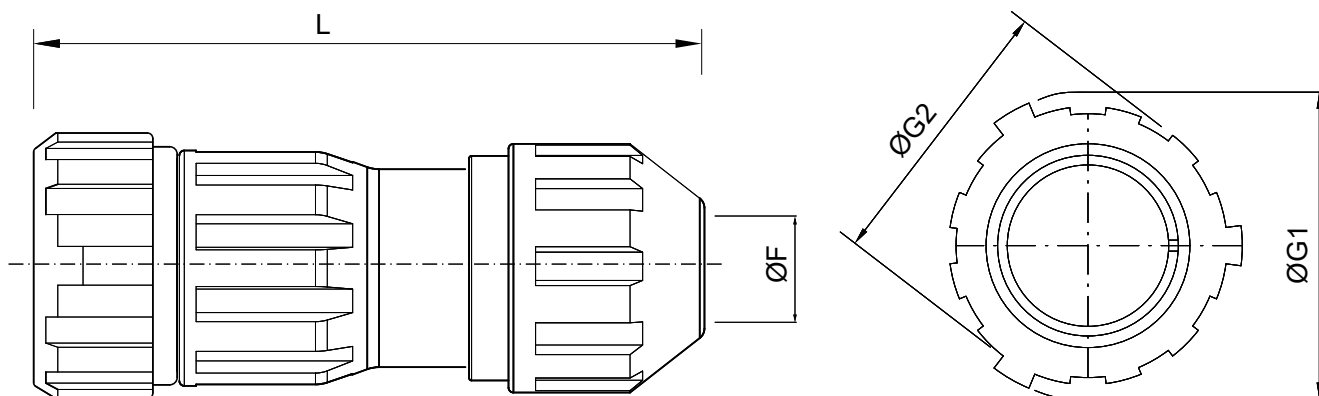

Shell size	ØG1	ØG2	L max	ØF	
				Min	Max
18	49	43.5	102	9.6	15.9
20	51.5	46	120	11.3	19
22	56	50.5	120	11.3	19
24	60	54	145	15.5	23.8
28	67	61	145	15.5	23.8
32	76	69	147	23.4	31.8
36	82	73.5	155	25.4	35
40	88	80	160	30	41.3

Dimensions in mm

Dimension "L" can be different from the value indicated according to backshells accessories, wires size and some special insert configurations.

CVBSG - Bayonet Connector with external insulated coating

RF	CVBSG		61	DAM	T	20-4	S	X	CR	CD5	F7		N
Series Code	Shell Material	Shell Type	Connector Class								Shell finish		

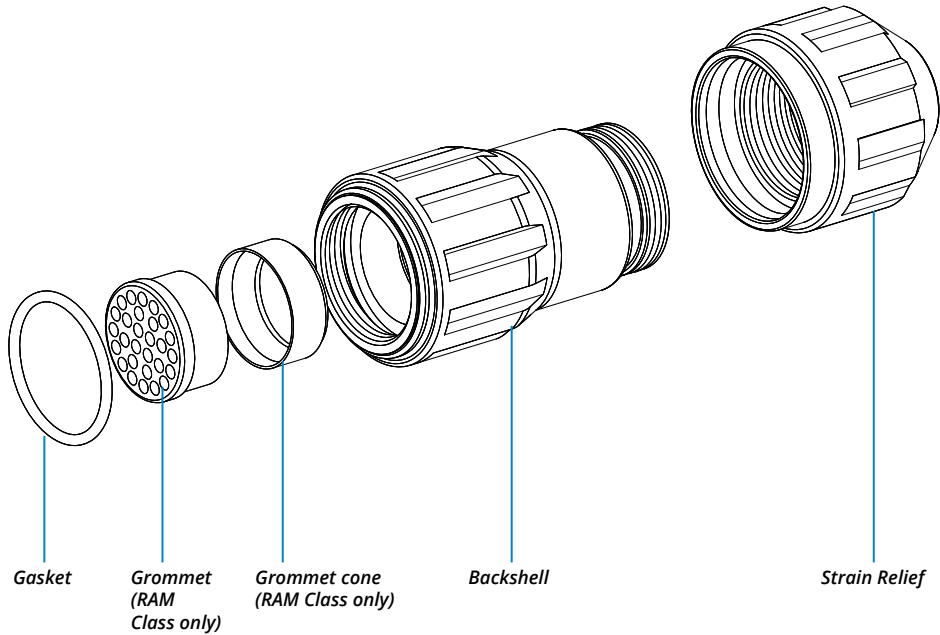

The accessories for this class are not always available in stock for all sizes; we suggest you consult our Sales Office for availability

RF	Insulating material	RF	Fire resistant rubber	S	Contact Gender	S	Socket contacts
CVBSG	Series Code	CVBSG	Bayonet Connector with external insulated coating	P		P	Pin contacts
	Shell Material	-	Aluminum	X	Polarization Code**		Alternate Positions
61	Shell Type	61	Plug Connector Rubber covered coupling nut (short version)	CR	Contact Termination	-	Solder contacts
DAM	Connector Class	DAM	with waterproof O-ring (IP67***)	CR		CR	Crimp contacts
		RAM	with waterproof O-ring and grommet (IP67***)	LC		LC	Less contacts
T	Connector Modification**	T	With plastic caps	CD5	Contact Plating	-	Silver plating
20-4	Insert Arrangement		Size - Type	F7	Shell finish	CD5	Gold plating
				F7		F7	Black epoxy varnish (*)
				F16		F16	CCF - Black passivation (*) - conductive
				F26		F26	hard anodization (*)
				N	Modification Code**	N	Consult our sales office
				S		S	

*** Protection degree: IP 67 (only in the mating area with mated connectors) according to EN 60529 (*) RoHS compliance (**) If required

P/N Sample: RF CVBSG 61DAMT 20-4SX CR CD5 F7 N

CVBSG - Bayonet Connector with external insulated coating

Plug Connector with rubber covered coupling nut (short version) (61) with Backshell Class (DA..M - RA..M)

Connector with backshell provided with an internal Metric or PG thread suitable for Cable Glands or conduit adapters. Rubber covered coupling nut (short version) able to protect against dust and impact.

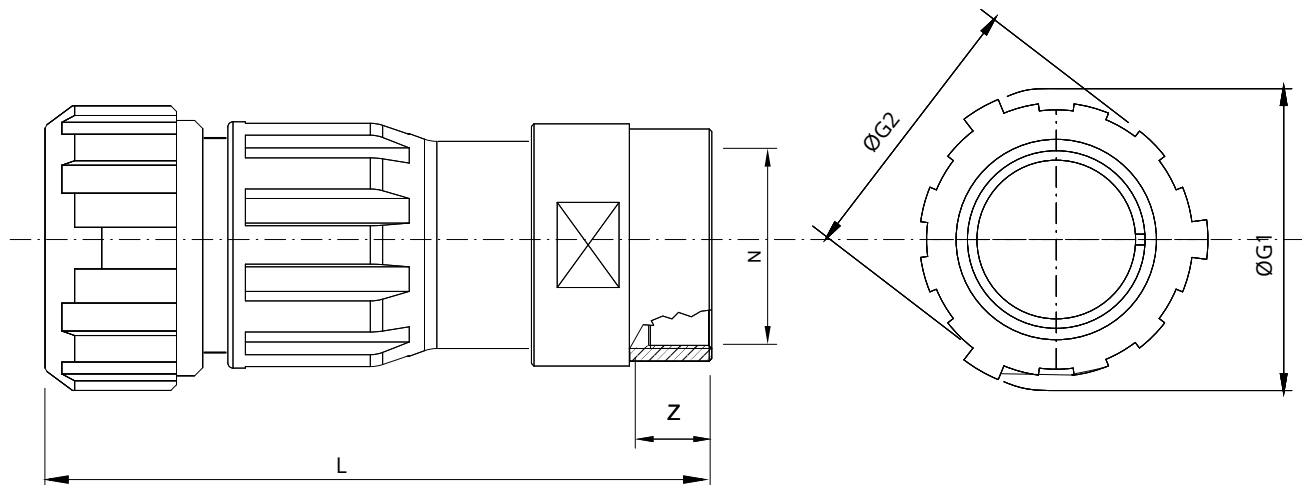

Shell size	ØG1	ØG2	L max	Z min	N Backshell Metric Thread
18	49	43.5	99	12	M20
20	51.5	46	116	15	M25
22	56	50.5	116	15	M25
24	60	54	141	16	M32
28	67	61	141	16	M32
32	76	69	143	16	M32
36	82	73.5	151	16	M32
40	88	80	156	16	M32

Dimensions in mm

Dimension "L" can be different from the value indicated according to backshells accessories, wires size and some special insert configurations.

CVBSG - Bayonet Connector with external insulated coating

RF	CVBSG		61	DA	T	20-4	S	X	M12	CR	CD5	F7		N
Series Code	Series Code	Shell Type	Connector Class	Connector Class	Connector Modification**	Insert Arrangement	Contact Gender	Polarization Code**	Backshell internal thread	Contact Termination	Contact Plating	Shell finish		Modification Code**

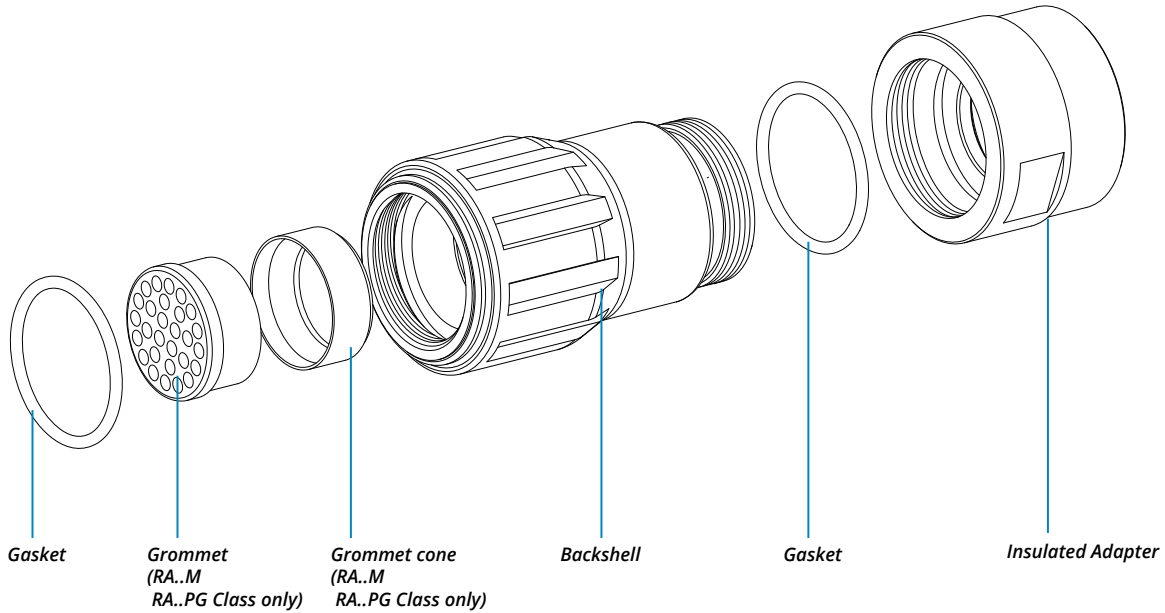

The accessories for this class are not always available in stock for all sizes; we suggest you consult our Sales Office for availability

RF	Insulating material	RF	Fire resistant rubber	S	Contact Gender	S	Socket contacts
CVBSG	Series Code	CVBSG	Bayonet Connector with external insulated coating	X	Polarization Code**		Alternate Positions
	Shell Material	-	Aluminum	M12	Backshell internal thread	M	Provided with an internal Metric thread
61	Shell Type	61	Plug Connector Rubber covered coupling nut (short version)	PG		PG	Provided with an internal PG thread
DA	Connector Class	DA	with waterproof O-ring (IP67***)	-	Contact Termination	-	Solder contacts
		RA	with waterproof O-ring and grommet (IP67***)	CR		CR	Crimp contacts
T	Connector Modification**	T	With plastic caps	LC		LC	Less contacts
20-4	Insert Arrangement		Size - Type	CD5	Contact Plating	-	Silver plating
				F7		CD5	Gold plating
				F16	Shell finish	F7	Black epoxy varnish (*)
				F26		F16	CCF - Black passivation (*) - conductive
				N	Modification Code**	F26	hard anodization (*)
				S		N	Consult our sales office

*** Protection degree: IP 67 (only in the mating area with mated connectors) according to EN 60529 (*) RoHS compliance (**) If required

P/N Sample: RF CVBSG 06DAT 20-4SX M12 CR CD5 F7 N

CVBSG - Bayonet Connector with external insulated coating

Plug Connector with rubber covered coupling nut (short version) (81) with 90° Elbow Class (DA..M - RA..M)

Connector with backshell provided with an internal Metric or PG thread suitable for Cable Glands or conduit adapters. Rubber covered coupling nut (short version) able to protect against dust and impact.

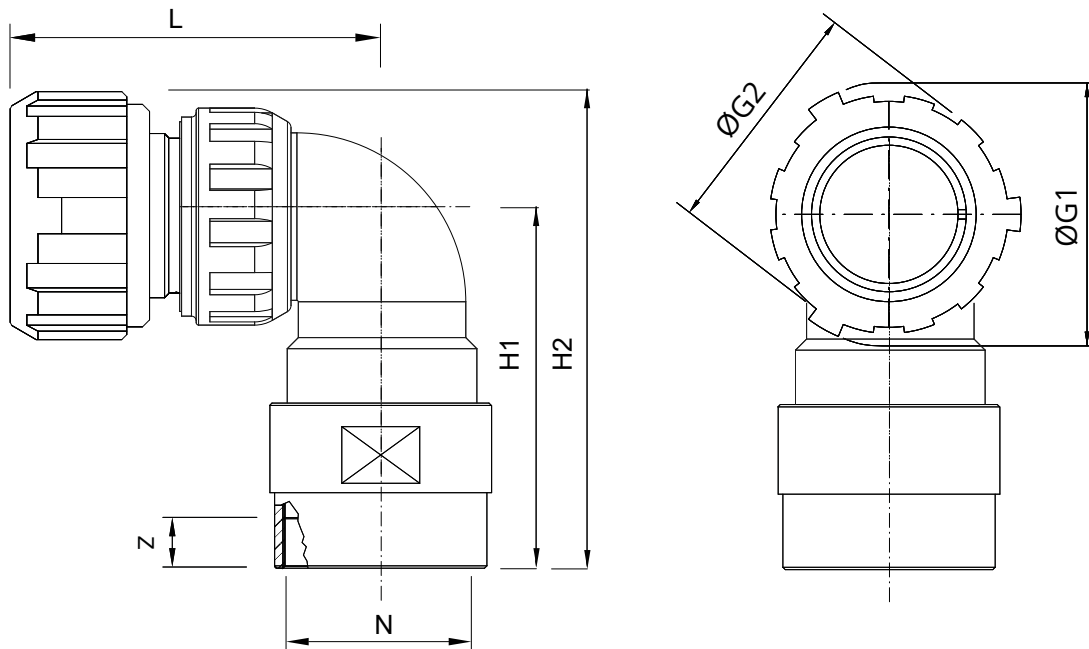

Shell size	ØG1	ØG2	L max	H1	H2	Z min	N Backshell Metric Thread
18	49	43.5	68	65	89.5	12	M20
20	51.5	46	71	67	92.8	15	M25
22	56	50.5	71	73	101	15	M25
24	60	54	76	80	110	16	M32
28	67	61	76	82	115.5	16	M32
32	76	69	80	84	122	16	M32
36	82	73.5	84	92	133	16	M32
40	88	80	88	94	138	16	M32

Dimensions in mm

Dimension "L" can be different from the value indicated according to backshells accessories, wires size and some special insert configurations.

CVBSG - Bayonet Connector with external insulated coating



Series Code

Shell Type

Connector Class

Backshell internal thread

Shell finish

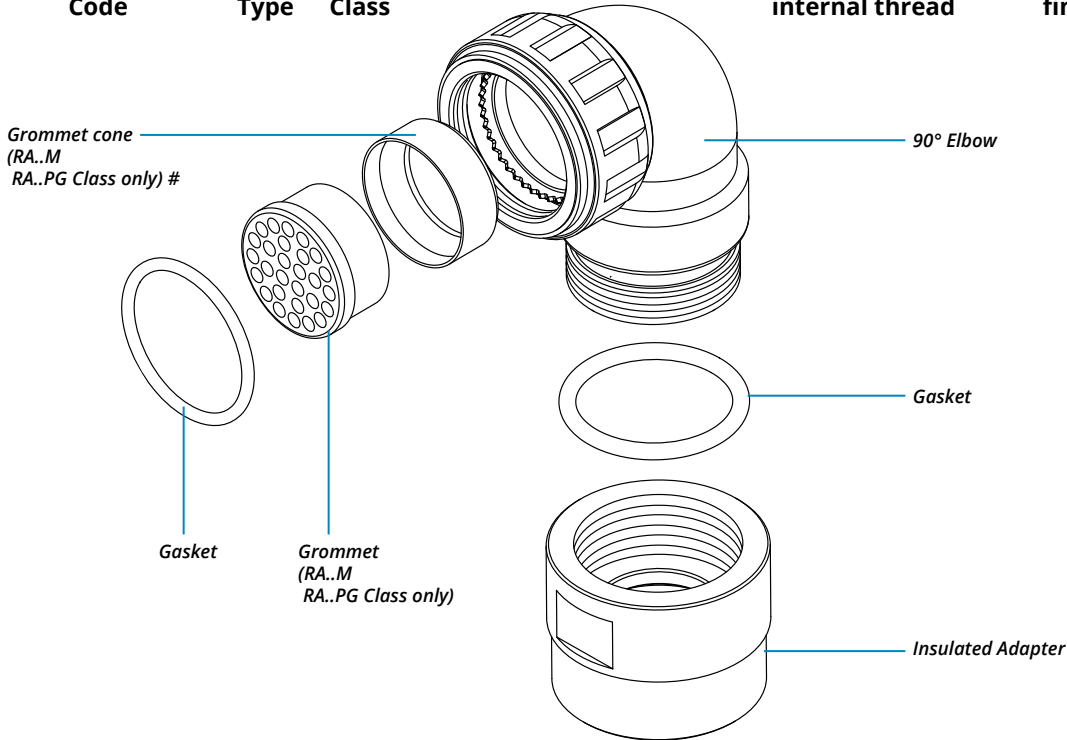

The accessories for this class are not always available in stock for all sizes; we suggest you consult our Sales Office for availability

RF	Insulating material	RF	Fire resistant rubber	S	Contact Gender	S	Socket contacts
CVBSG	Series Code	CVBSG	Bayonet Connector with external insulated coating	P		P	Pin contacts
	Shell Material	-	Aluminum	X	Polarization Code**		Alternate Positions
81	Shell Type	81	Plug Connector with 90° elbow Rubber covered coupling nut (short version)	M12	Backshell internal thread	M	Provided with an internal Metric thread
DA	Connector Class	DA	with waterproof O-ring (IP67***)	PG		PG	Provided with an internal PG thread
RA		RA	with waterproof O-ring and grommet (IP67***) #	CR	Contact Termination	-	Solder contacts
T	Connector Modification**	T	With plastic caps	CR		CR	Crimp contacts
20-4	Insert Arrangement		Size - Type	LC		LC	Less contacts
				CD5	Contact Plating	-	Silver plating
				F7	Shell finish	F7	Black epoxy varnish (*)
				N	Modification Code**	F16	CCF - Black passivation (*) - conductive
						N	Consult our sales office
						S	

*** Protection degree: IP 67 (only in the mating area with mated connectors) according to EN 60529 (*) RoHS compliance (**) If required

P/N Sample: RF CVBSG 81DAT 20-4SX M12 CR CD5 F7 N

(#) In some sizes the grommet cone is not needed

CVBR - Bayonet Connector roller studs - for harsh applications - Shell - Backshell

RF CVBR 00 DA T 20-27 S X PG16 CR CD5 F7 G N



Designed to build a product even more suitable for the harshest application. The studs of the plug connector coupling and a higher number of operations due to a lower wear of the coupling ramps. CVBR series can be supplied from size 18 to size 40.

Main characteristics:

- Suitable for higher number of operations
- The roller-stud guarantees an easier coupling due to a lower wear of the coupling ramps

Available in several versions suitable for all applications and manufactured in different materials and finishes:

- Aluminum alloy with different types of protection finishes according to RoHS directives.

CVBR	Series Code	CVBR	Bayonet Connector roller studs - for harsh applications
	Shell Material	-	Aluminum
00	Shell Type	xx	Flange/Plug Shell with ramp/threaded or with nut
DA	Connector Class	xx	With backshell
T	Connector Modification**	T	With plastic caps
		FF	Receptacle connector with threaded holes (to specify for 00/02/05 shell only)
		FP	Receptacle connector with through holes (to specify for 03 shell only)
		FS	Receptacle connector with countersunk holes
		V	Insert and contacts sealed (solder only)
PG16	Backshell Conduits size or internal thread	-	Without internal thread
		xx	Conduits size or internal thread
F7	Shell finish	F4	CCF - Green passivation - conductive
		F5	Electroless nickel (<i>RoHS compliance</i>)
		F7	Black epoxy varnish (<i>RoHS compliance</i>)
		F16	CCF - Black passivation - conductive (<i>RoHS compliance</i>)
		F26	Hard anodization (<i>RoHS compliance</i>)
G	Panel Gasket	-	Without gasket
		G	With waterproof panel gasket
		G2	With shielded panel gasket
		G3	With waterproof shielded panel gasket
N	Modification Code**	N	Contacts and hole plugs (Consult our sales office)
		S	Customization (Consult our sales office)

CVBR - Bayonet Connector roller studs - for harsh applications

Plug Connector (06) with Backshell Class (A - DA - RA)

Connector with backshell provided with an external thread suitable for MS3057...A or C type Cable-Clamps (to be ordered separately).

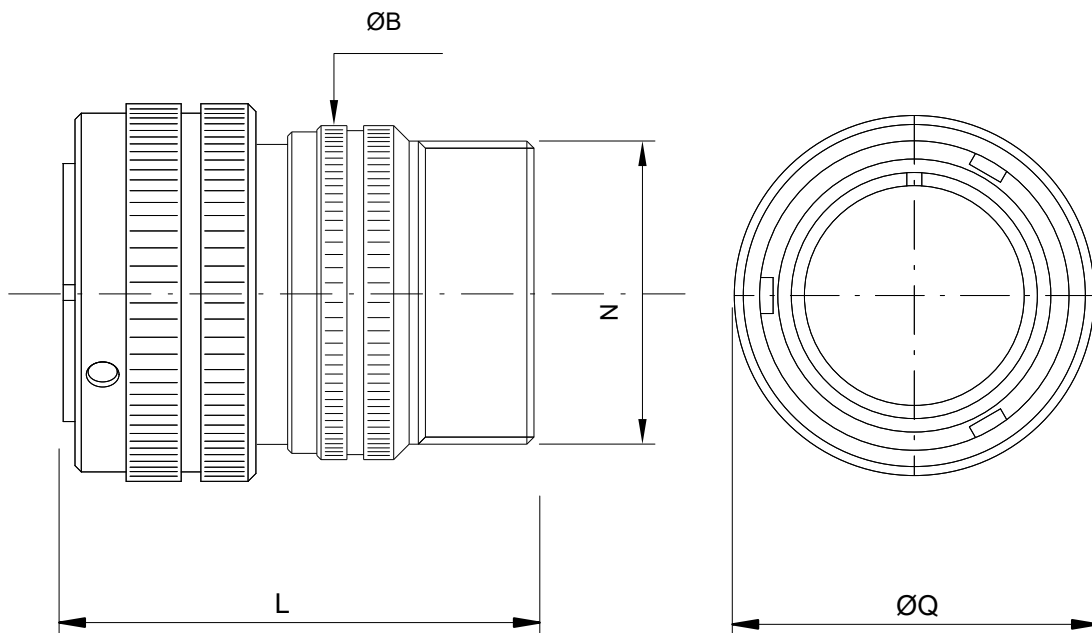
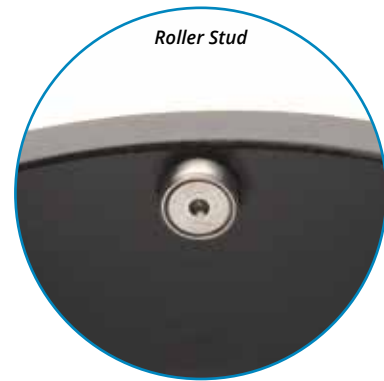

Shell size	ØQ ±0.2	ØB ±0.2	L max	N Backshell Thread in inches
10SL	23.3	20	36	5/8"-24 UNEF
14S	29.5	24	43	3/4"-20 UNEF
16S	33	27	43	7/8"-20 UNEF
16	33	27	49	7/8"-20 UNEF
18	37	30	52	1"-20 UNEF
20	41	32	52.5	1" 3/16-18 UNEF
22	43	37	55	1" 3/16-18 UNEF
24	48	40	55	1" 7/16-18 UNEF
28	53	45	62	1" 7/16-18 UNEF
32	60	52	62	1" 3/4-18 UNS
36	66.2	58	62	2"-18 UNS
40	72.4	63.8	64	2"1/4-16 UN

Dimensions in mm

Dimension "L" can be different from the value indicated according to backshells accessories, wires size and some special insert configurations.

CVBR - Bayonet Connector roller studs - for harsh applications



Series Code: CVBR
 Shell Material: 06
 Shell Type: DA
 Connector Class: T

Shell finish: F7

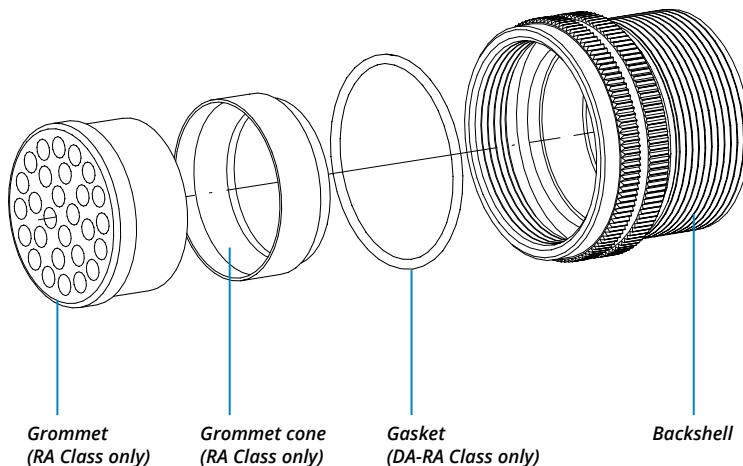

RF	Insulating material	-	Chloroprene rubber
		V	Fluoride rubber
		S	Silicone rubber
		RF	Fire resistant rubber
CVBR	Series Code	CVBR	Bayonet Connector roller studs - for harsh applications
	Shell Material	-	Aluminum
06	Shell Type	06	Plug Connector
DA	Connector Class	A	non watertight
		DA	with waterproof O-ring (IP67***)
		RA	with waterproof O-ring and grommet (IP67***)
T	Connector Modification**	T	With plastic caps
20-27	Insert Arrangement		Size - Type

S	Contact Gender	S	Socket contacts
		P	Pin contacts
X	Polarization Code**		Alternate Positions
CR	Contact Termination	-	Solder contacts
		CR	Crimp contacts
		LC	Less contacts
CD5	Contact Plating	-	Silver plating
		CD5	Gold plating
		F5	Electroless nickel (*)
		F7	Black epoxy varnish (*)
F7	Shell finish	F16	CCF - Black passivation (*) - conductive
		F26	hard anodization (*)
		N	Consult our sales office
N	Modification Code**	N	Consult our sales office
		S	Consult our sales office

*** Protection degree: IP 67 (only in the mating area with mated connectors) according to EN 60529 (*) RoHS compliance (**) If required

P/N Sample: RF CVBR 06DAT 20-27SX CR CD5 F7 N

CVBR - Bayonet Connector roller studs - for harsh applications

Plug Connector (06) with Backshell Class (AF - F)

Connector provided with backshell, MS3057...A type Cable-Clamp and bushing MS3420... (for single wire)

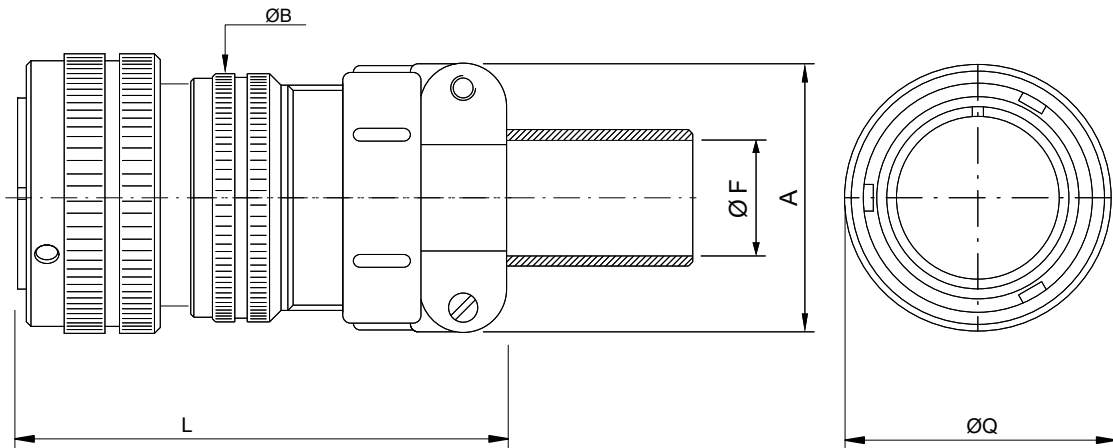
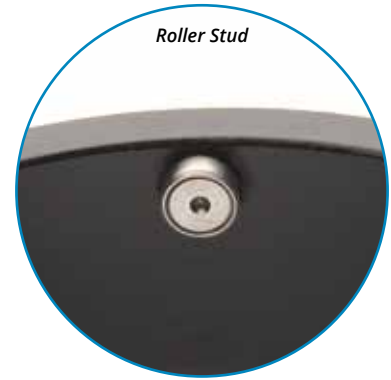

Shell size	ØQ ±0.2	L max	ØB ±0.2	A max	ØF cable max dimension
10SL	23.3	46	20	22.5	5.6
14S	29.5	55	24	28	7.9
16S	33	56.5	27	30	11
16	33	62.5	27	30	11
18	37	67.5	30	31.7	14.2
20	41	68	32	37.5	15.8
22	43	70.5	37	37.5	15.8
24	48	70.5	40	43.5	19
28	53	77.5	45	43.5	19
32	60	77.5	52	51.7	23.8
36	66.2	77.5	58	58.5	31.7
40	72.4	93	63.8	68.5	34.9

Dimensions in mm

Dimension "L" can be different from the value indicated according to backshells accessories, wires size and some special insert configurations.

CVBR - Bayonet Connector roller studs - for harsh applications



Series Code Shell Material Type Connector Class

Shell finish

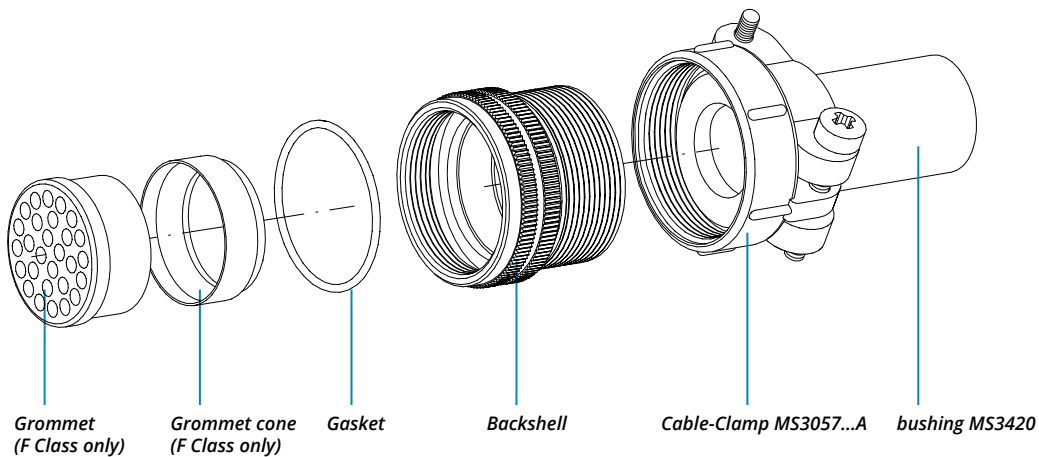

RF	Insulating material	-	Chloroprene rubber
		V	Fluoride rubber
		S	Silicone rubber
		RF	Fire resistant rubber
CVBR	Series Code	CVBR	Bayonet Connector roller studs - for harsh applications
	Shell Material	-	Aluminum
06	Shell Type	06	Plug Connector
AF	Connector Class	AF	with waterproof O-ring (IP54)
		F	with waterproof O-ring and grommet (IP54)
T	Connector Modification**	T	With plastic caps
20-27	Insert Arrangement		Size - Type

S	Contact Gender	S	Socket contacts
		P	Pin contacts
X	Polarization Code**		Alternate Positions
CR	Contact Termination	-	Solder contacts
		CR	Crimp contacts
		LC	Less contacts
CD5	Contact Plating	-	Silver plating
		CD5	Gold plating
		F5	Electroless nickel (*)
F7	Shell finish	F7	Black epoxy varnish (*)
		F16	CCF - Black passivation (*) - conductive
		F26	hard anodization (*)
N	Modification Code**	N	Consult our sales office
		S	

P/N Sample: RF CVBR 06AFT 20-27SX CR CD5 F7 N

(*) RoHS compliance

(**) If required

CVBR - Bayonet Connector roller studs - for harsh applications

Plug Connector (08) with 90° Elbow Class (A - DA - RA)

Connector with 90° elbow provided with an external thread suitable for MS3057...A or C type Cable-Clamps (to be ordered separately).

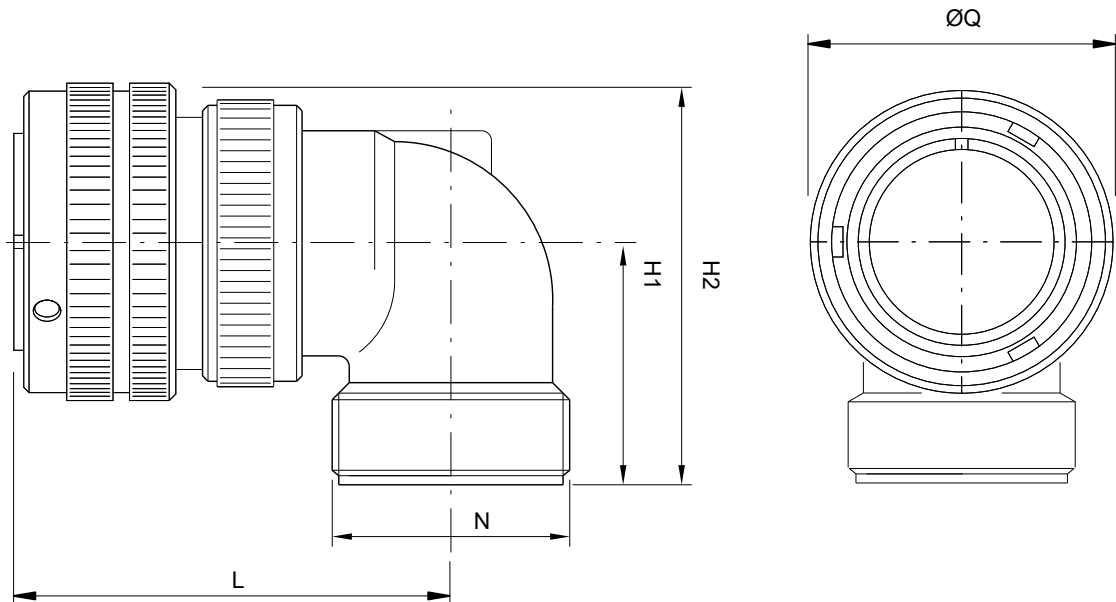
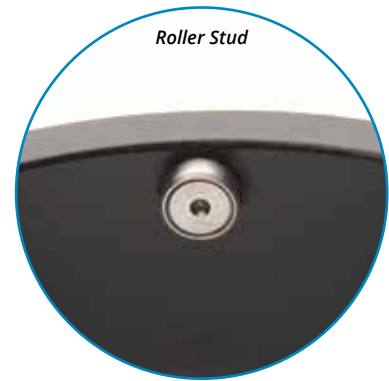

Shell size	ØQ ±0.2	L max	H1 max	H2 max	N Backshell Thread in inches
10SL	23.3	45.5	27	38.7	5/8"-24 UNEF
14S	29.5	45.5	27	41.3	3/4"-20 UNEF
16S	33	47	29	44.9	7/8"-20 UNEF
16	33	56.5	29	44.9	7/8"-20 UNEF
18	37	57.5	31	48.1	1"-20 UNEF
20	41	60	33	51.7	1" 3/16-18 UNEF
22	43	62.5	35	55.3	1" 3/16-18 UNEF
24	48	65.5	38	59.8	1" 7/16-18 UNEF
28	53	65.5	40	65	1" 7/16-18 UNEF
32	60	70	46	74.1	1" 3/4-18 UNS
36	66.2	73.5	49	80.3	2"-18 UNS
40	72.4	78.5	53	87.6	2" 1/4-16 UN

Dimensions in mm

Dimension "L" can be different from the value indicated according to backshells accessories, wires size and some special insert configurations.

CVBR - Bayonet Connector roller studs - for harsh applications

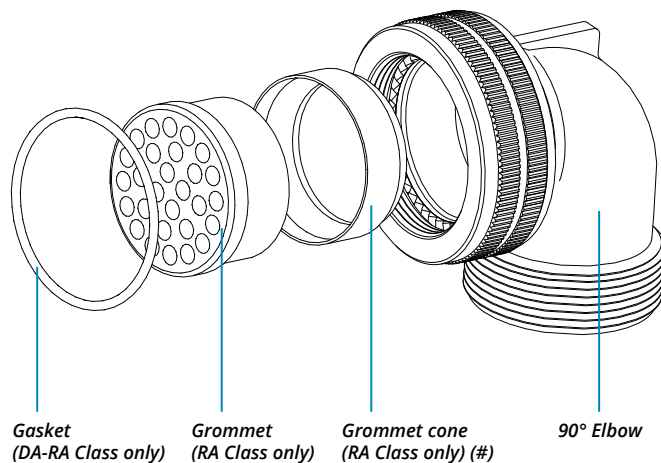

RF	Insulating material	-	Chloroprene rubber
		V	Fluoride rubber
		S	Silicone rubber
		RF	Fire resistant rubber
CVBR	Series Code	CVBR	Bayonet Connector roller studs - for harsh applications
	Shell Material	-	Aluminum
08	Shell Type	08	Plug Connector with 90° elbow
		A	non watertight
DA	Connector Class	DA	with waterproof O-ring (IP67***)
		RA	with waterproof O-ring and grommet (IP67***) (#)
T	Connector Modification**	T	With plastic caps
20-27	Insert Arrangement		Size - Type

S	Contact Gender	S	Socket contacts
		P	Pin contacts
X	Polarization Code**		Alternate Positions
CR	Contact Termination	-	Solder contacts
		CR	Crimp contacts
		LC	Less contacts
CD5	Contact Plating	-	Silver plating
		CD5	Gold plating
F7	Shell finish	F5	Electroless nickel (*)
		F7	Black epoxy varnish (*)
		F16	CCF - Black passivation (*) - conductive
N	Modification Code**	N	Consult our sales office
		S	

*** Protection degree: IP 67 (only in the mating area with mated connectors) according to EN 60529 (*) RoHS compliance (**) If required

P/N Sample: RF CVBR 08DAT 20-27SX CR CD5 F7 N

(#) In some sizes the grommet cone is not needed

GVJ - Oversize Bayonet Connector - Shell - Backshell

RF GVJ 00 DA T 20-27 S X PG16 CR CD5 F7 N



This series benefits of the bayonet coupling itself suitable for the harsh conditions typical in railway applications and of more robust and reliable features obtained by the following modifications.

Main characteristics:

- Bigger shell thicknesses to guarantee resistance against impact and harsh environment.
- Rubber-jacketed coupling nut also in the standard series. The roller studs make the coupling easier and allow a bigger number of operations due to a lower wear of the coupling ramps.
- Five key polarization system (a big key and four smaller).
- Increased dimensions to install insulators with bigger number of contacts (on equal service rating) or bigger contact sizes (for higher voltage).
- Wide range of rear accessories and adapters for all types of cables and protections available.

Available in several versions suitable for all applications and manufactured in different materials and finishes:

- Aluminum alloy with different types of protection finishes according to RoHS directives.

GVJ	Series Code	GVJ	Oversize Bayonet Connector
	Shell Material	-	Aluminum
00	Shell Type	xx	Flange/Plug Shell with ramp/threaded or with nut
DA	Connector Class	xx	With backshell
T	Connector Modification**	T	With plastic caps
		FF	Receptacle connector with threaded holes (to specify for 00/02/05 shell only)
		FP	Receptacle connector with through holes (to specify for 03 shell only)
		FS	Receptacle connector with countersunk holes
		V	Insert and contacts sealed (solder only)
PG16	Backshell Conduits size or internal thread	-	Without internal thread
		xx	Conduits size or internal thread
F7	Shell finish	F7	Black epoxy varnish (<i>RoHS compliance</i>)
		F16	CCF - Black passivation - conductive (<i>RoHS compliance</i>)
		F26	Hard anodization (<i>RoHS compliance</i>)
-	Gasket	-	Supplied with O Ring
N	Modification Code**	N	Contacts and hole plugs (Consult our sales office)
		S	Customization (Consult our sales office)

GVJ - Oversize Bayonet Connector

Front Mounting Receptacle (00) with Backshell Class (A - DA - RA)

Connector with backshell provided with an external thread suitable for MS3057...A or C type Cable-Clamps (to be ordered separately).

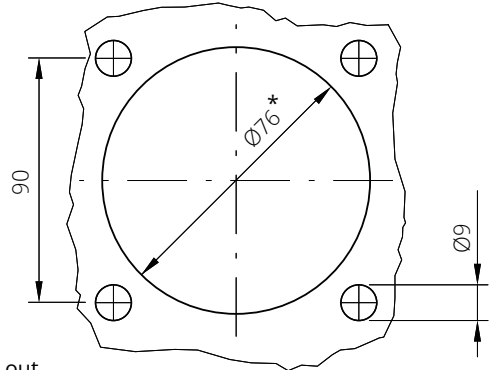

Panel cut out

* For installation with backshell mounted, consult our sales office.

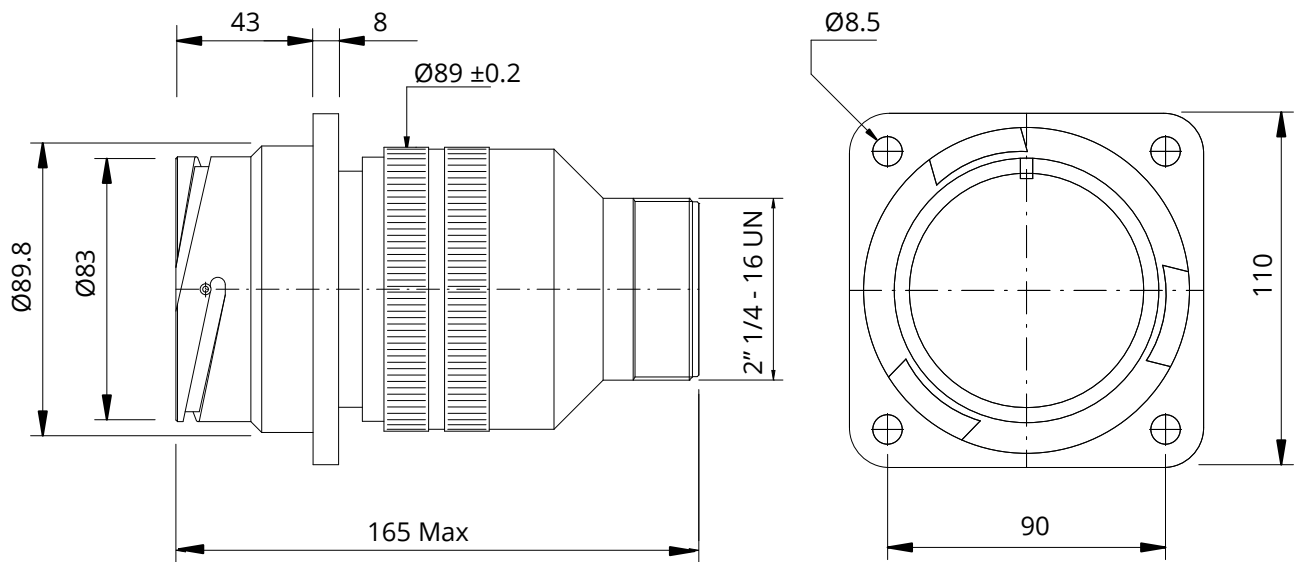

Inserts Arrangement	Insert Material	Contacts Type	N. Total Contacts	Contacts Size/Current Rating								Service Rating Code
				4/0 225A	0 150A	4 80A	8 46A	12 23A	16 13A	18 7.5A	20 7.5A	
● 48A4	Thermoplastic	KT	4	4								D (1250 Vdc - 900 Vac)
48A7	Thermoplastic	KT	6	4			2					A (700 Vdc - 500 Vac)
48-6	Rubber	ST	6	3				3				A (700 Vdc - 500 Vac)
48A9	Rubber	ST	9	3	2			4				(PD4 OV3) 400V
48A58	Rubber	ST	58				1	57				A (700 Vdc - 500 Vac)
48A101	Rubber	ST	101						101			A (700 Vdc - 500 Vac)

● Grommet Available

Dimensions in mm

Dimension "L" can be different from the value indicated according to backshells accessories, wires size and some special insert configurations.

GVJ - Oversize Bayonet Connector



Series Shell Shell Connector
Code Material Type Class

Shell
finish

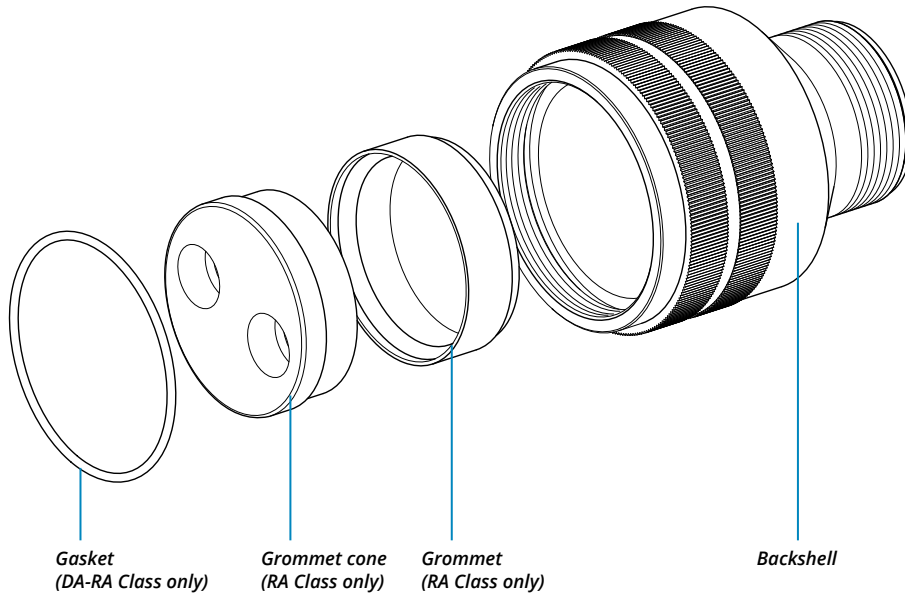

RF	Insulating material	-	Chloroprene rubber or thermoplastic Inserts ****	S	Contact Gender	S	Socket contacts
		RF	Fire resistant rubber	P		P	Pin contacts
GVJ	Series Code	GVJ	Oversize Bayonet Connector with protected mating ramps	X	Polarization Code**		Alternate Positions
	Shell Material	-	Aluminum	CR	Contact Termination	-	Solder contacts
				CR		CR	Crimp contacts
				LC		LC	Less contacts
00	Shell Type	00	Front mounting Receptacle	CD5	Contact Plating	-	Silver plating
		A	non watertight	CD5		CD5	Gold plating
		DA	with waterproof O-ring (IP67***)	F7	Shell finish	F7	Black epoxy varnish (*)
		RA	with waterproof O-ring and grommet (IP67***)	F16		F16	CCF - Black passivation (*) - conductive
				F26		F26	hard anodization (*)
T	Connector Modification**	T	With plastic caps	-	Gasket	-	Supplied with O Ring
		-	Receptacle connector with through holes	N	Modification Code**	N	Consult our sales office
48-6	Insert Arrangement		Size - Type	S		S	

**** Other insulating parts in fire resistant rubber

*** Protection degree: IP 67 (only in the mating area with mated connectors) according to EN 60529 (*) RoHS compliance (**) If required

P/N Sample: RF GVJ 00DAT 48-6SX CR CD5 F7 N

GVJ - Oversize Bayonet Connector

Front Mounting Receptacle (00) with Backshell Class (AC - ACF)

Connector provided with backshell, MS3057...C type Cable-Clamp (for jacketed cable)

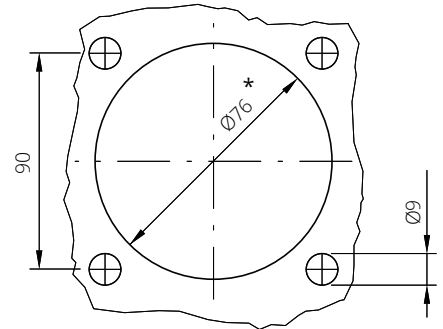

Panel cut out

* For installation with backshell mounted, consult our sales office.

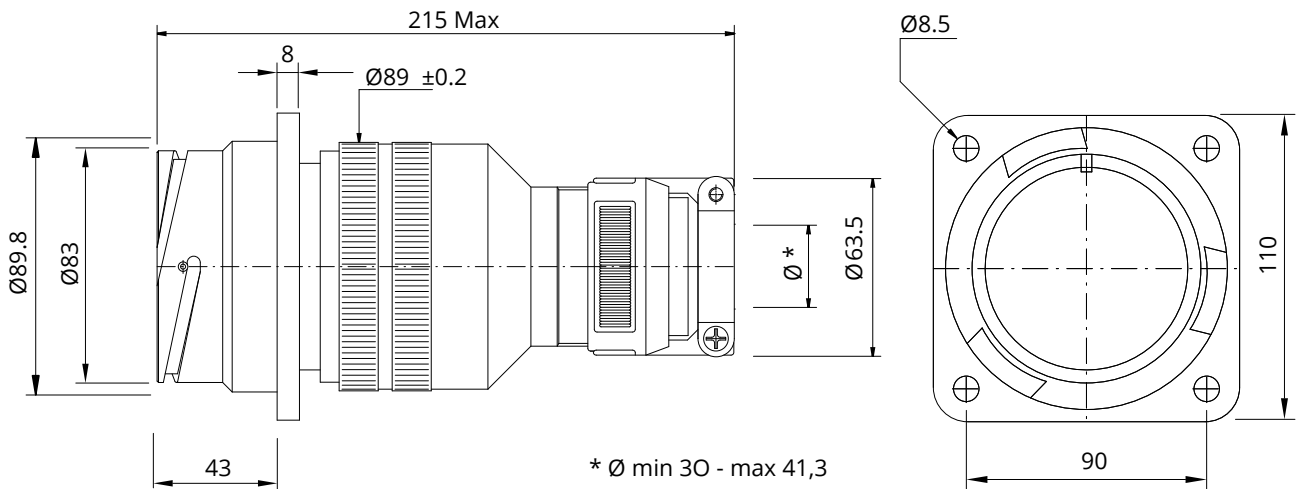

Inserts Arrangement	Insert Material	Contacts Type	N. Total Contacts	Contacts Size/Current Rating								Service Rating Code
				4/0 225A	0 150A	4 80A	8 46A	12 23A	16 13A	18 7.5A	20 7.5A	
● 48A4	Thermoplastic	KT	4	4								D (1250 Vdc - 900 Vac)
48A7	Thermoplastic	KT	6	4			2					A (700 Vdc - 500 Vac)
48-6	Rubber	ST	6	3				3				A (700 Vdc - 500 Vac)
48A9	Rubber	ST	9	3	2			4				(PD4 OV3) 400V
48A58	Rubber	ST	58				1	57				A (700 Vdc - 500 Vac)
48A101	Rubber	ST	101						101			A (700 Vdc - 500 Vac)

● Grommet Available

Dimensions in mm

Dimension "L" can be different from the value indicated according to backshells accessories, wires size and some special insert configurations.

GVJ - Oversize Bayonet Connector



Series Code: RF
 Shell Material Type: GVJ
 Shell Type: 00
 Connector Class: AC

Shell finish: F7

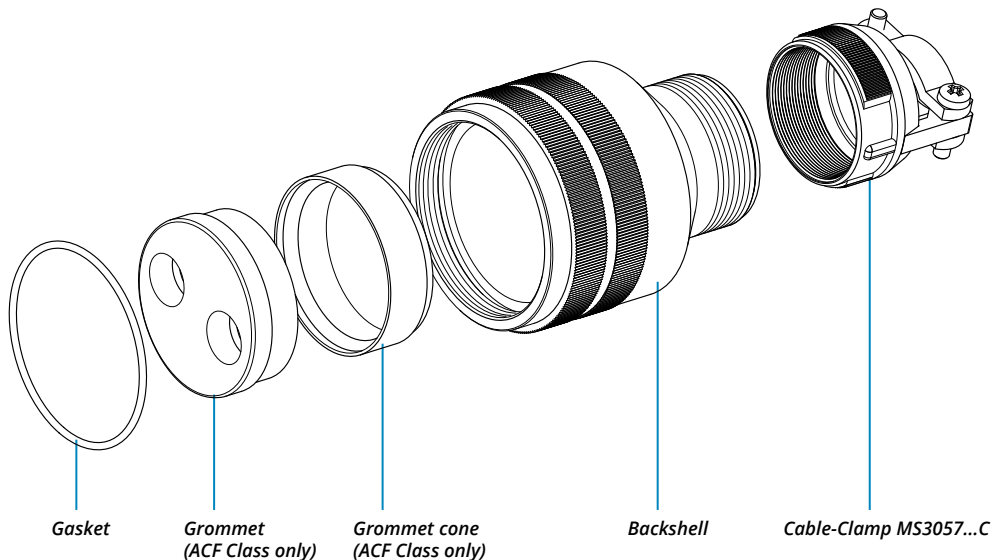

RF	Insulating material	-	Chloroprene rubber or thermoplastic Inserts ****
		RF	Fire resistant rubber
GVJ	Series Code	GVJ	Oversize Bayonet Connector with protected mating ramps
	Shell Material	-	Aluminum
00	Shell Type	00	Front mounting Receptacle
AC	Connector Class	ACF	with waterproof O-ring and grommet (IP67)
		AC	with waterproof O-ring (IP67)
T	Connector Modification**	T	With plastic caps
		-	Receptacle connector with through holes
48-6	Insert Arrangement		Size - Type

S	Contact Gender	S	Socket contacts
		P	Pin contacts
X	Polarization Code**		Alternate Positions
CR	Contact Termination	-	Solder contacts
		CR	Crimp contacts
		LC	Less contacts
CD5	Contact Plating	-	Silver plating
		CD5	Gold plating
		F7	Black epoxy varnish (*)
F7	Shell finish	F16	CCF - Black passivation (*) - conductive
		F26	hard anodization (*)
		-	Supplied with O Ring
N	Modification Code**	N	Consult our sales office
		S	

**** Other insulating parts in fire resistant rubber

P/N Sample: RF GVJ 00ACT 48-6SX CR CD5 F7 N

(*) RoHS compliance

(**) If required

GVJ - Oversize Bayonet Connector

Front Mounting Receptacle (00) with Backshell Class (DA..M - RA..M DA..PG - RA..PG)

Connector with backshell provided with an internal Metric or PG thread suitable for Cable Glands or conduit adapters.

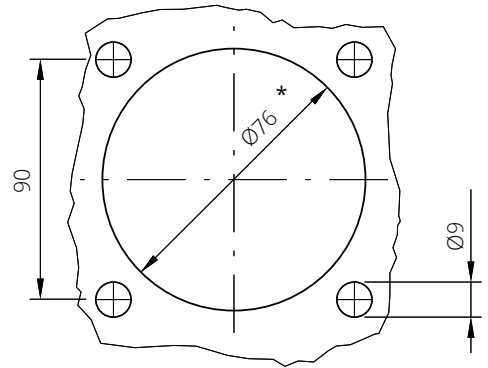

Panel cut out

* For installation with backshell mounted, consult our sales office.

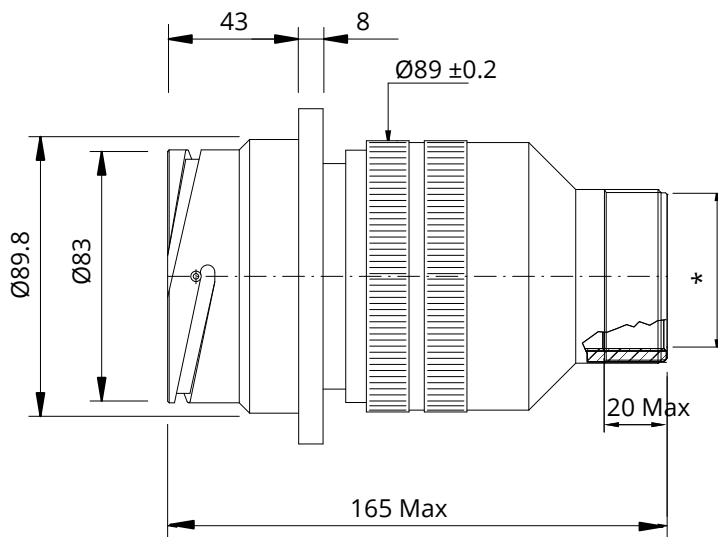

* M50 / M63 / M75 / PG48

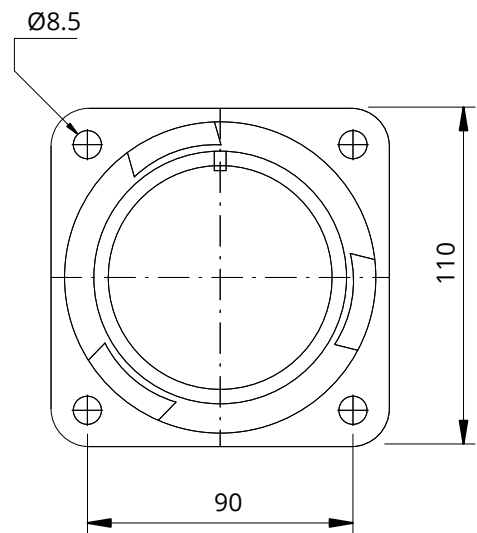

Inserts Arrangement	Insert Material	Contacts Type	N. Total Contacts	Contacts Size/Current Rating								Service Rating Code	
				4/0 225A	0 150A	4 80A	8 46A	12 23A	16 13A	18 7.5A	20 7.5A		
● 48A4	Thermoplastic	KT	4	4									D (1250 Vdc - 900 Vac)
48A7	Thermoplastic	KT	6	4			2						A (700 Vdc - 500 Vac)
48-6	Rubber	ST	6	3				3					A (700 Vdc - 500 Vac)
48A9	Rubber	ST	9	3	2			4					(PD4 OV3) 400V
48A58	Rubber	ST	58				1	57					A (700 Vdc - 500 Vac)
48A101	Rubber	ST	101							101			A (700 Vdc - 500 Vac)

● Grommet Available

Dimensions in mm

Dimension "L" can be different from the value indicated according to backshells accessories, wires size and some special insert configurations.

GVJ - Oversize Bayonet Connector

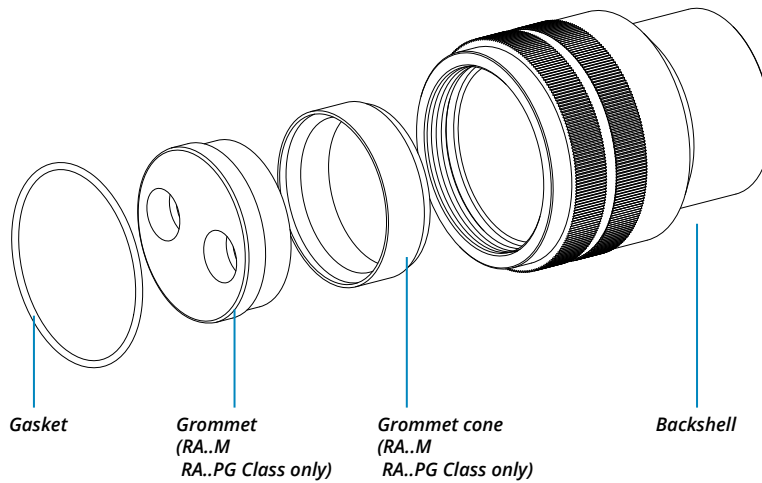

RF	Insulating material	-	Chloroprene rubber or thermoplastic Inserts ****	X	Polarization Code**		Alternate Positions
GVJ	Series Code	GVJ	Oversize Bayonet Connector with protected mating ramps	M12	Backshell internal thread	M	Provided with an internal Metric thread
	Shell Material	-	Aluminum			PG	Provided with an internal PG thread
00	Shell Type	00	Front mounting Receptacle	CR	Contact Termination	-	Solder contacts
DA	Connector Class	DA	with waterproof O-ring (IP67***)			CR	Crimp contacts
		RA	with waterproof O-ring and grommet (IP67***)			LC	Less contacts
T	Connector Modification**	T	With plastic caps	CD5	Contact Plating	-	Silver plating
		-	Receptacle connector with through holes			CD5	Gold plating
48-6	Insert Arrangement		Size - Type	F7	Shell finish	F7	Black epoxy varnish (*)
S	Contact Gender	S	Socket contacts			F16	CCF - Black passivation (*) - conductive
		P	Pin contacts			F26	hard anodization (*)
				-	Gasket	-	Supplied with O Ring
				N	Modification Code**	N	Consult our sales office
						S	

**** Other insulating parts in fire resistant rubber

*** Protection degree: IP 67 (only in the mating area with mated connectors) according to EN 60529 (*) RoHS compliance (**) If required

P/N Sample: RF GVJ 00DAT 48-6SX M12 CR CD5 F7 N

GVJ - Oversize Bayonet Connector

Front Mounting Receptacle (020) without Accessories (To be purchased separately)

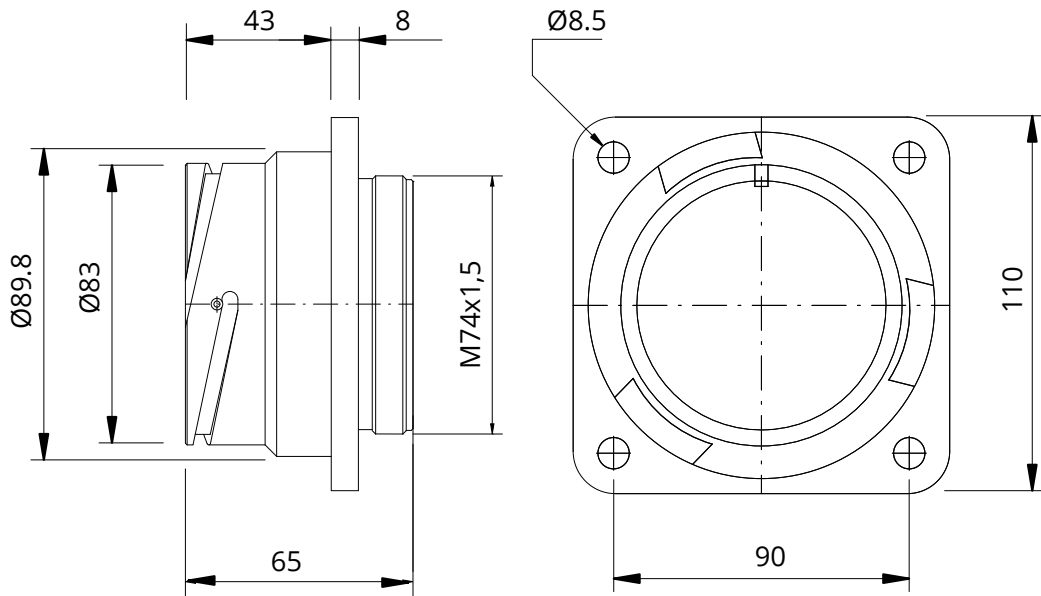
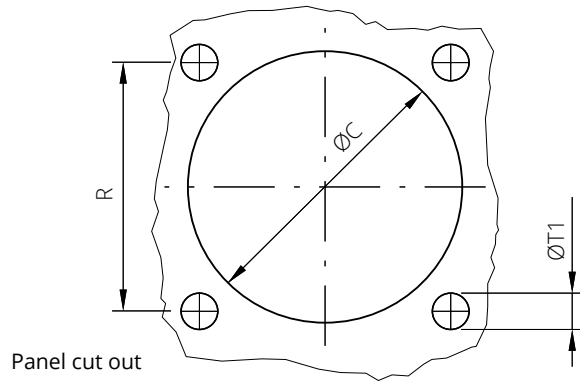

Inserts Arrangement	Insert Material	Contacts Type	N. Total Contacts	Contacts Size/Current Rating								Service Rating Code
				4/0 225A	0 150A	4 80A	8 46A	12 23A	16 13A	18 7.5A	20 7.5A	
● 48A4	Thermoplastic	KT	4	4								D (1250 Vdc - 900 Vac)
48A7	Thermoplastic	KT	6	4			2					A (700 Vdc - 500 Vac)
48-6	Rubber	ST	6	3				3				A (700 Vdc - 500 Vac)
48A9	Rubber	ST	9	3	2			4				(PD4 OV3) 400V
48A58	Rubber	ST	58				1	57				A (700 Vdc - 500 Vac)
48A101	Rubber	ST	101						101			A (700 Vdc - 500 Vac)

● Grommet Available

Dimensions in mm

Dimension "L" can be different from the value indicated according to backshells accessories, wires size and some special insert configurations.

GVJ - Oversize Bayonet Connector

RF	GVJ		020		T	48-6	S	X		CR	CD5	F7		N
	Series Code		Shell Type									Shell finish		

RF	Insulating material	-	Chloroprene rubber or thermoplastic Inserts ****
		RF	Fire resistant rubber
GVJ	Series Code	GVJ	Oversize Bayonet Connector with protected mating ramps
	Shell Material	-	Aluminum
020	Shell Type	020	Front mounting Receptacle
T	Connector Modification**	T	With plastic caps
		-	Receptacle connector with through holes
48-6	Insert Arrangement		Size - Type
S	Contact Gender	S	Socket contacts
		P	Pin contacts
X	Polarization Code**		Alternate Positions
CR	Contact Termination	-	Solder contacts
		CR	Crimp contacts
		LC	Less contacts
CD5	Contact Plating	-	Silver plating
		CD5	Gold plating
F7	Shell finish	F7	Black epoxy varnish (*)
		F16	CCF - Black passivation (*) - conductive
		F26	hard anodization (*)
-	Gasket	-	Supplied with O Ring
N	Modification Code**	N	Consult our sales office
		S	

P/N Sample: RF GVJ 020T 48-6SX CR CD5 F7 N

(*) RoHS compliance

(**) If required

GVJ - Oversize Bayonet Connector

Rear Mounting Receptacle (038) with 90° Elbow Class (A - DA - RA)

Connector with 90° elbow provided with an external thread suitable for MS3057...A or C type Cable-Clamps (to be ordered separately).

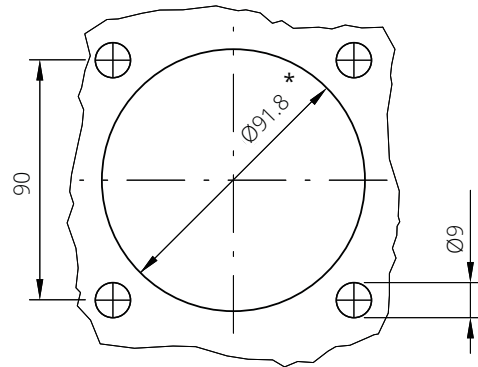

Panel cut out

* For installation with backshell mounted, consult our sales office.

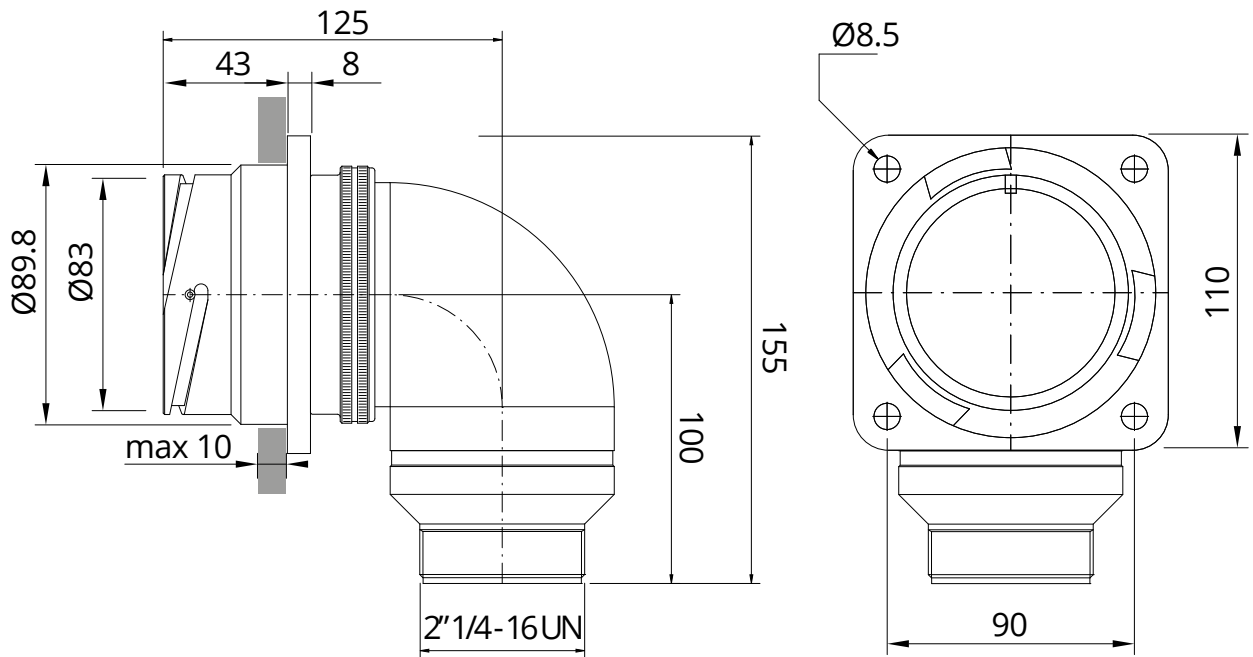

Inserts Arrangement	Insert Material	Contacts Type	N. Total Contacts	Contacts Size/Current Rating								Service Rating Code	
				4/0 225A	0 150A	4 80A	8 46A	12 23A	16 13A	18 7.5A	20 7.5A		
● 48A4	Thermoplastic	KT	4	4									D (1250 Vdc - 900 Vac)
48A7	Thermoplastic	KT	6	4			2						A (700 Vdc - 500 Vac)
48-6	Rubber	ST	6	3				3					A (700 Vdc - 500 Vac)
48A9	Rubber	ST	9	3	2			4					(PD4 OV3) 400V
48A58	Rubber	ST	58				1	57					A (700 Vdc - 500 Vac)
48A101	Rubber	ST	101							101			A (700 Vdc - 500 Vac)

● Grommet Available

Dimensions in mm

Dimension "L" can be different from the value indicated according to backshells accessories, wires size and some special insert configurations.

GVJ - Oversize Bayonet Connector



Series Code: **GVJ**
 Shell Material Type: **038**
 Connector Class: **DA**

Shell finish: **F7**

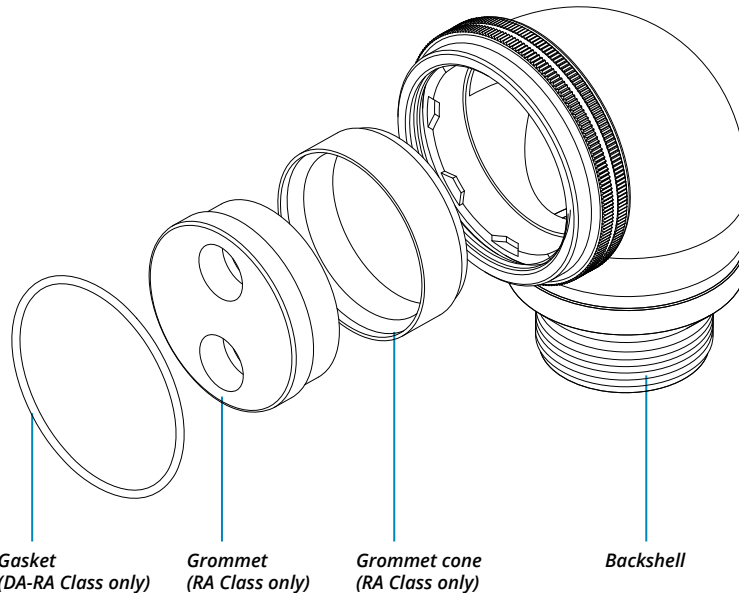

RF	Insulating material	-	Chloroprene rubber or thermoplastic Inserts ****	S	Contact Gender	S	Socket contacts
		RF	Fire resistant rubber			P	Pin contacts
GVJ	Series Code	GVJ	Oversize Bayonet Connector with protected mating ramps	X	Polarization Code**		Alternate Positions
	Shell Material	-	Aluminum	CR	Contact Termination	-	Solder contacts
						CR	Crimp contacts
						LC	Less contacts
038	Shell Type	038	Rear mounting Receptacle with 90° elbow	CD5	Contact Plating	-	Silver plating
		A	non watertight			CD5	Gold plating
DA	Connector Class	DA	with waterproof O-ring (IP67****)	F7	Shell finish	F7	Black epoxy varnish (*)
		RA	with waterproof O-ring and grommet (IP67****)			F16	CCF - Black passivation (*) - conductive
		T	With plastic caps			F26	hard anodization (*)
T	Connector Modification**	-	Receptacle connector with through holes	-	Gasket	-	Supplied with O Ring
		FF	Receptacle connector with threaded holes	N	Modification Code**	N	Consult our sales office
						S	
48-6	Insert Arrangement		Size - Type				

**** Other insulating parts in fire resistant rubber

*** Protection degree: IP 67 (only in the mating area with mated connectors) according to EN 60529 (*) RoHS compliance (***) If required

P/N Sample: RF GVJ 038DAT 48-6SX CR CD5 F7 N

GVJ - Oversize Bayonet Connector

Rear Mounting Receptacle (038) with 90° Elbow Class (AC - ACF)

Connector with 90° elbow provided with MS3057...C type Cable-Clamp (for jacketed cable)

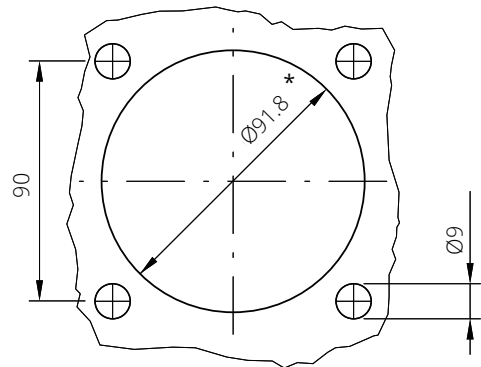

Panel cut out

* For installation with backshell mounted, consult our sales office.

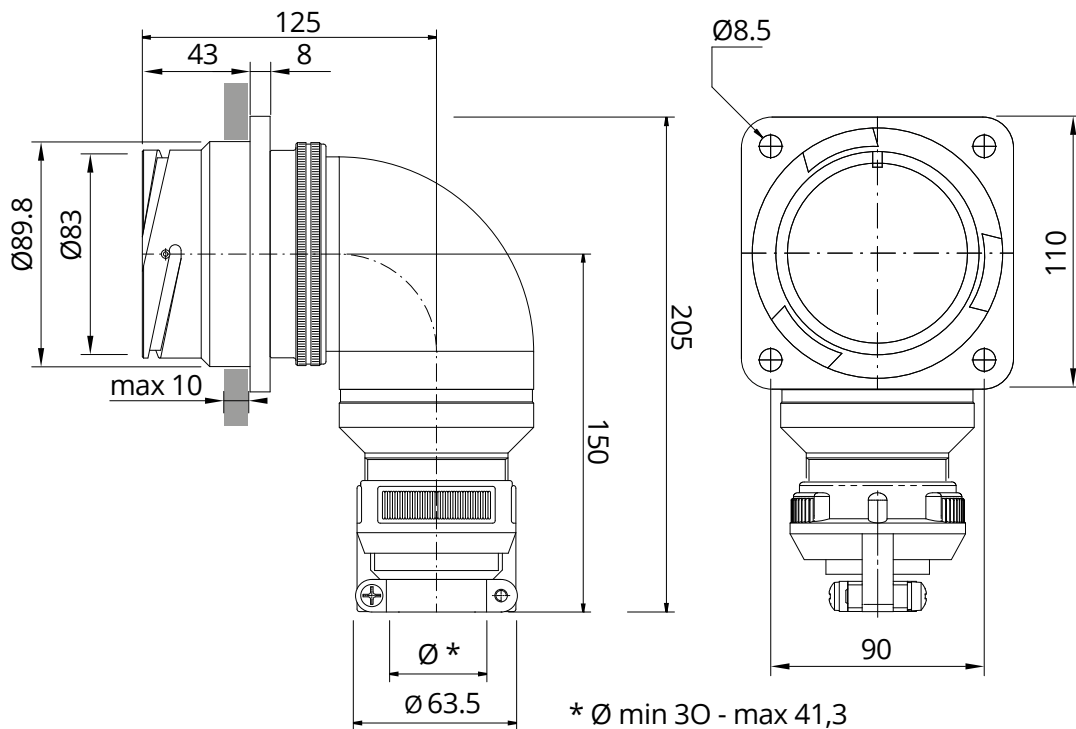

Inserts Arrangement	Insert Material	Contacts Type	N. Total Contacts	Contacts Size/Current Rating							Service Rating Code	
				4/0 225A	0 150A	4 80A	8 46A	12 23A	16 13A	18 7.5A		20 7.5A
● 48A4	Thermoplastic	KT	4	4								D (1250 Vdc - 900 Vac)
48A7	Thermoplastic	KT	6	4			2					A (700 Vdc - 500 Vac)
48-6	Rubber	ST	6	3				3				A (700 Vdc - 500 Vac)
48A9	Rubber	ST	9	3	2			4				(PD4 OV3) 400V
48A58	Rubber	ST	58				1	57				A (700 Vdc - 500 Vac)
48A101	Rubber	ST	101						101			A (700 Vdc - 500 Vac)

● Grommet Available

Dimensions in mm

Dimension "L" can be different from the value indicated according to backshells accessories, wires size and some special insert configurations.

GVJ - Oversize Bayonet Connector



Series Code

Shell Type

Connector Class

Shell finish

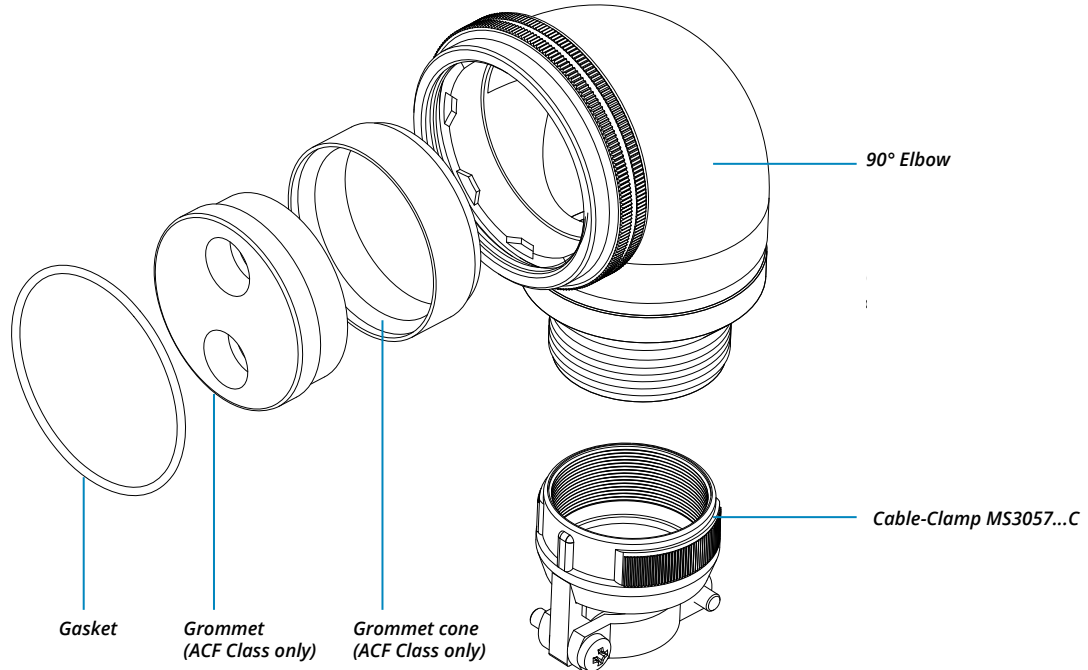

RF	Insulating material	-	Chloroprene rubber or thermoplastic Inserts ****
		RF	Fire resistant rubber
GVJ	Series Code	GVJ	Oversize Bayonet Connector with protected mating ramps
	Shell Material	-	Aluminum
038	Shell Type	038	Rear mounting Receptacle with 90° elbow
ACF	Connector Class	AC	with waterproof O-ring (IP67)
		ACF	with waterproof O-ring and grommet (IP67)
		T	With plastic caps
T	Connector Modification**	-	Receptacle connector with through holes
		FF	Receptacle connector with threaded holes
48-6	Insert Arrangement		Size - Type

S	Contact Gender	S	Socket contacts
		P	Pin contacts
X	Polarization Code**		Alternate Positions
		-	Solder contacts
CR	Contact Termination	CR	Crimp contacts
		LC	Less contacts
CD5	Contact Plating	-	Silver plating
		CD5	Gold plating
F7	Shell finish	F7	Black epoxy varnish (*)
		F16	CCF - Black passivation (*) - conductive
-	Gasket	-	Supplied with O Ring
N	Modification Code**	N	Consult our sales office
		S	

**** Other insulating parts in fire resistant rubber

P/N Sample: RF GVJ 038ACFT 48-6SX CR CD5 F7 N

(*) RoHS compliance

(**) If required

GVJ - Oversize Bayonet Connector

Rear Mounting Receptacle (038) with 90° Elbow Class (DA..M - RA..M)

Connector with 90° elbow provided provided with an internal Metric or PG thread suitable for Cable Glands or conduit adapters.

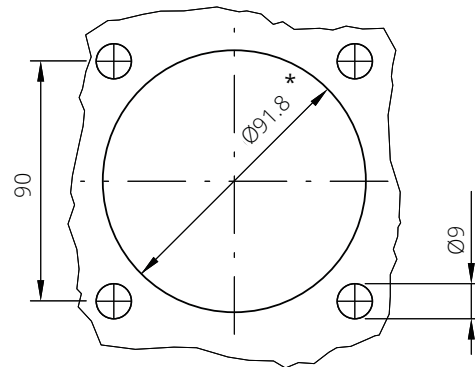

Panel cut out

* For installation with backshell mounted, consult our sales office.

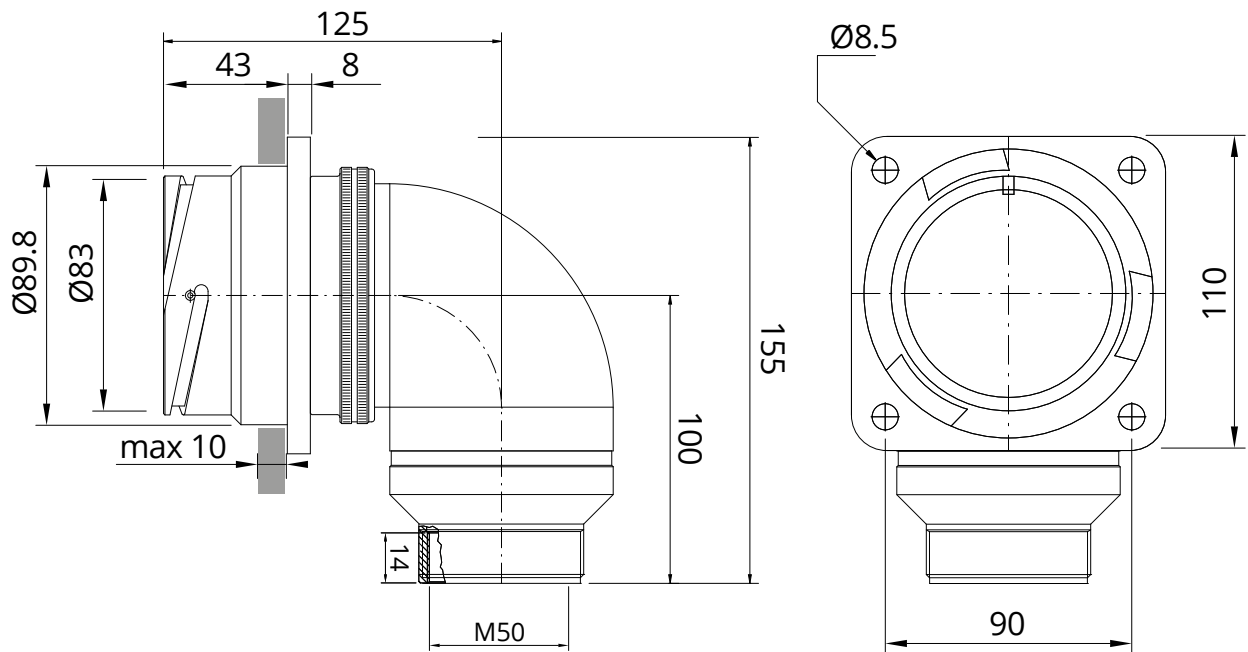

Inserts Arrangement	Insert Material	Contacts Type	N. Total Contacts	Contacts Size/Current Rating							Service Rating Code	
				4/0 225A	0 150A	4 80A	8 46A	12 23A	16 13A	18 7.5A		20 7.5A
● 48A4	Thermoplastic	KT	4	4								D (1250 Vdc - 900 Vac)
48A7	Thermoplastic	KT	6	4			2					A (700 Vdc - 500 Vac)
48-6	Rubber	ST	6	3				3				A (700 Vdc - 500 Vac)
48A9	Rubber	ST	9	3	2			4				(PD4 OV3) 400V
48A58	Rubber	ST	58				1	57				A (700 Vdc - 500 Vac)
48A101	Rubber	ST	101						101			A (700 Vdc - 500 Vac)

● Grommet Available

Dimensions in mm

Dimension "L" can be different from the value indicated according to backshells accessories, wires size and some special insert configurations.

GVJ - Oversize Bayonet Connector



Series Code: **GVJ** Shell Material Type: [] Shell Type: **038** Connector Class: **DA** Modification: **T** Insert Arrangement: **48-6** Contact Gender: **S** Polarization Code: **X** Backshell internal thread: **M12** Contact Termination: **CR** Contact Plating: **CD5** Shell finish: **F7** [] Modification Code: **N**

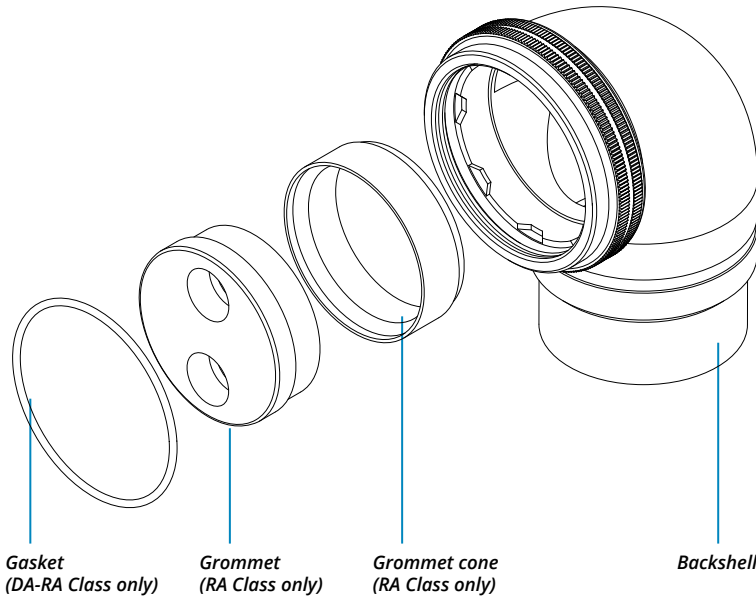

RF	Insulating material	-	Chloroprene rubber or thermoplastic Inserts ****	S	Contact Gender	S	Socket contacts
		RF	Fire resistant rubber			P	Pin contacts
GVJ	Series Code	GVJ	Oversize Bayonet Connector with protected mating ramps	X	Polarization Code**		Alternate Positions
[]	Shell Material	-	Aluminum	M12	Backshell internal thread	M	Provided with an internal Metric thread
						PG	Provided with an internal PG thread
038	Shell Type	038	Rear mounting Receptacle with 90° elbow	CR	Contact Termination	-	Solder contacts
		A	non watertight			CR	Crimp contacts
DA	Connector Class	DA	with waterproof O-ring (IP67***)	CD5	Contact Plating	-	Silver plating
		RA	with waterproof O-ring and grommet (IP67***)			CD5	Gold plating
		T	With plastic caps	F7	Shell finish	F7	Black epoxy varnish (*)
T	Connector Modification**	-	Receptacle connector with through holes			F16	CCF - Black passivation (*) - conductive
		FF	Receptacle connector with threaded holes	-	Gasket	-	Supplied with O Ring
48-6	Insert Arrangement		Size - Type	N	Modification Code**	N	Consult our sales office
						S	

**** Other insulating parts in fire resistant rubber

*** Protection degree: IP 67 (only in the mating area with mated connectors) according to EN 60529 (*) RoHS compliance (***) If required

P/N Sample: RF GVJ 038DAT 48-6SX M12 CR CD5 F7 N

GVJ - Oversize Bayonet Connector

Plug Connector with rubber covered coupling nut (06) with Backshell Class (A - DA - RA)

Connector with backshell provided with an external thread suitable for MS3057...A or C type Cable-Clamps (to be ordered separately). Rubber covered coupling nut able to protect against dust and impact; protected mating ramps.

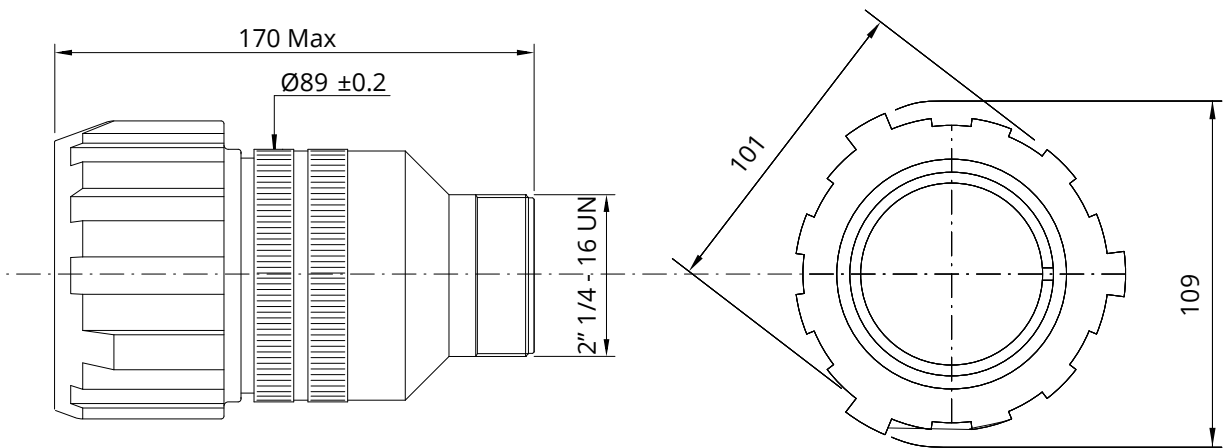

Inserts Arrangement	Insert Material	Contacts Type	N. Total Contacts	Contacts Size/Current Rating								Service Rating Code
				4/0 225A	0 150A	4 80A	8 46A	12 23A	16 13A	18 7.5A	20 7.5A	
● 48A4	Thermoplastic	KT	4	4								D (1250 Vdc - 900 Vac)
48A7	Thermoplastic	KT	6	4			2					A (700 Vdc - 500 Vac)
48-6	Rubber	ST	6	3				3				A (700 Vdc - 500 Vac)
48A9	Rubber	ST	9	3	2			4				(PD4 OV3) 400V
48A58	Rubber	ST	58				1	57				A (700 Vdc - 500 Vac)
48A101	Rubber	ST	101						101			A (700 Vdc - 500 Vac)

● Grommet Available

Dimensions in mm

Dimension "L" can be different from the value indicated according to backshells accessories, wires size and some special insert configurations.

GVJ - Oversize Bayonet Connector

RF	GVJ		06	DA	T	48-6	S	X		CR	CD5	F7		N
	Series Code		Shell Type	Connector Class								Shell finish		

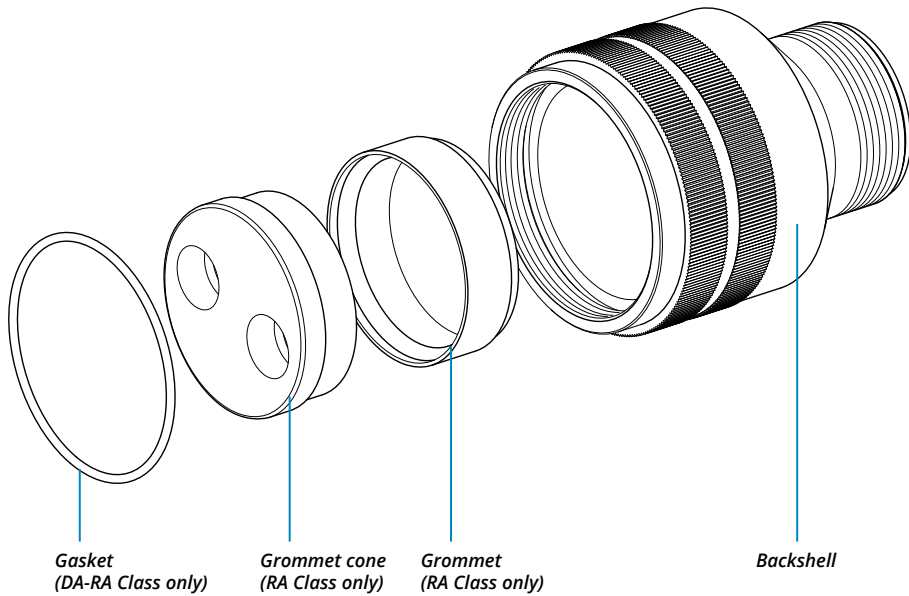

RF	Insulating material	-	Chloroprene rubber or thermoplastic Inserts ****	S	Contact Gender	S	Socket contacts
		RF	Fire resistant rubber			P	Pin contacts
GVJ	Series Code	GVJ	Oversize Bayonet Connector with protected mating ramps	X	Polarization Code**		Alternate Positions
	Shell Material	-	Aluminum	CR	Contact Termination	-	Solder contacts
						CR	Crimp contacts
						LC	Less contacts
06	Shell Type	06	Plug Connector	CD5	Contact Plating	-	Silver plating
		A	non watertight			CD5	Gold plating
DA	Connector Class	DA	with waterproof O-ring (IP67***)	F7	Shell finish	F7	Black epoxy varnish (*)
		RA	with waterproof O-ring and grommet (IP67***)			F16	CCF - Black passivation (*) - conductive
						F26	hard anodization (*)
T	Connector Modification**	T	With plastic caps	N	Modification Code**	N	Consult our sales office
						S	
48-6	Insert Arrangement		Size - Type				

**** Other insulating parts in fire resistant rubber

*** Protection degree: IP 67 (only in the mating area with mated connectors) according to EN 60529 (*) RoHS compliance (***) If required

P/N Sample: RF GVJ 06DAT 48-6SX CR CD5 F7 N

GVJ - Oversize Bayonet Connector

Plug Connector with rubber covered coupling nut (06) with Backshell Class (AC - ACF)

Connector provided with backshell, MS3057...C type Cable-Clamp. (for jacketed cable)
 Rubber covered coupling nut able to protect against dust and impact; protected mating ramps.

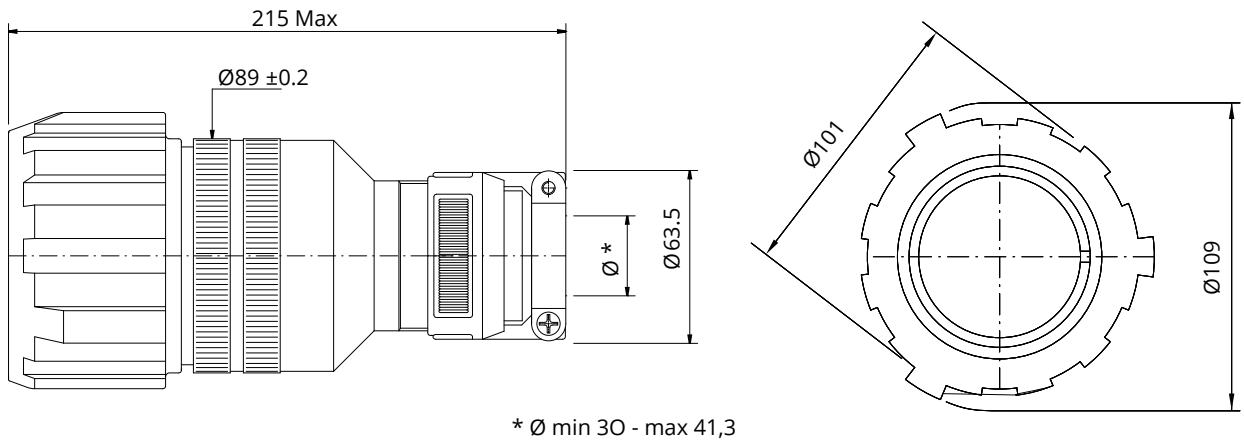

Inserts Arrangement	Insert Material	Contacts Type	N. Total Contacts	Contacts Size/Current Rating								Service Rating Code
				4/0 225A	0 150A	4 80A	8 46A	12 23A	16 13A	18 7.5A	20 7.5A	
● 48A4	Thermoplastic	KT	4	4								D (1250 Vdc - 900 Vac)
48A7	Thermoplastic	KT	6	4			2					A (700 Vdc - 500 Vac)
48-6	Rubber	ST	6	3				3				A (700 Vdc - 500 Vac)
48A9	Rubber	ST	9	3	2			4				(PD4 OV3) 400V
48A58	Rubber	ST	58				1	57				A (700 Vdc - 500 Vac)
48A101	Rubber	ST	101						101			A (700 Vdc - 500 Vac)

● Grommet Available

Dimensions in mm

Dimension "L" can be different from the value indicated according to backshells accessories, wires size and some special insert configurations.

GVJ - Oversize Bayonet Connector

RF	GVJ		06	ACF	T	48-6	S	X		CR	CD5	F7		N
Series Code	Shell Type	Connector Class										Shell finish		

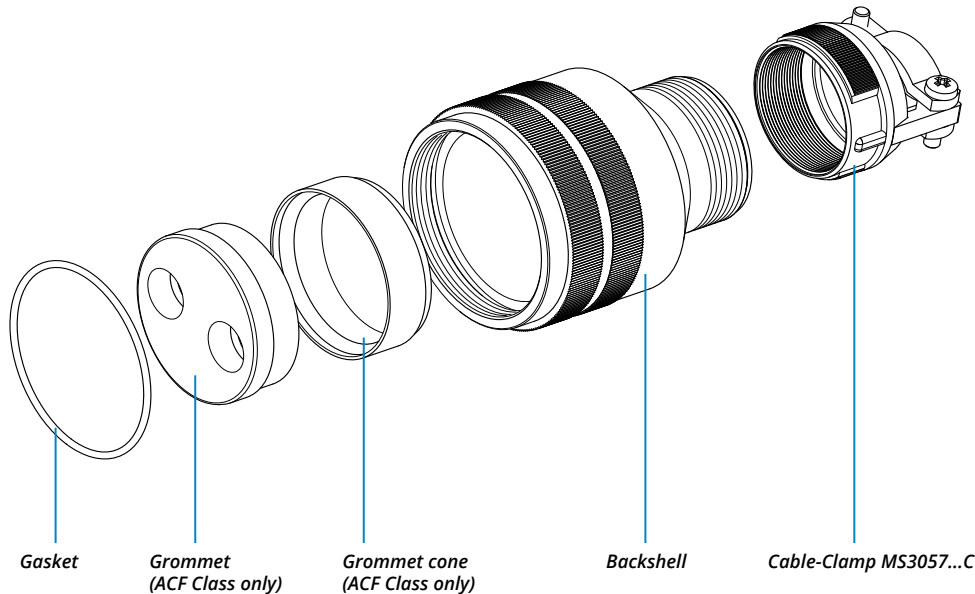

RF	Insulating material	-	Chloroprene rubber or thermoplastic Inserts ****	S	Contact Gender	S	Socket contacts
		RF	Fire resistant rubber			P	Pin contacts
GVJ	Series Code	GVJ	Oversize Bayonet Connector with protected mating ramps	X	Polarization Code**		Alternate Positions
	Shell Material	-	Aluminum	CR	Contact Termination	-	Solder contacts
						CR	Crimp contacts
						LC	Less contacts
06	Shell Type	06	Plug Connector	CD5	Contact Plating	-	Silver plating
						CD5	Gold plating
ACF	Connector Class	AC	with waterproof O-ring (IP67)	F7	Shell finish	F7	Black epoxy varnish (*)
		ACF	with waterproof O-ring and grommet (IP67)			F16	CCF - Black passivation (*) - conductive
						F26	hard anodization (*)
T	Connector Modification**	T	With plastic caps	N	Modification Code**	N	Consult our sales office
						S	
48-6	Insert Arrangement		Size - Type				

**** Other insulating parts in fire resistant rubber

P/N Sample: RF GVJ 06ACFT 48-6SX CR CD5 F7 N

(*) RoHS compliance

(**) If required

GVJ - Oversize Bayonet Connector

Plug Connector with rubber covered coupling nut (06) with Backshell Class (DA..M - RA..M DA..PG - RA..PG)

Connector with backshell provided with an internal Metric or PG thread suitable for Cable Glands or conduit adapters. Rubber covered coupling nut able to protect against dust and impact; protected mating ramps.

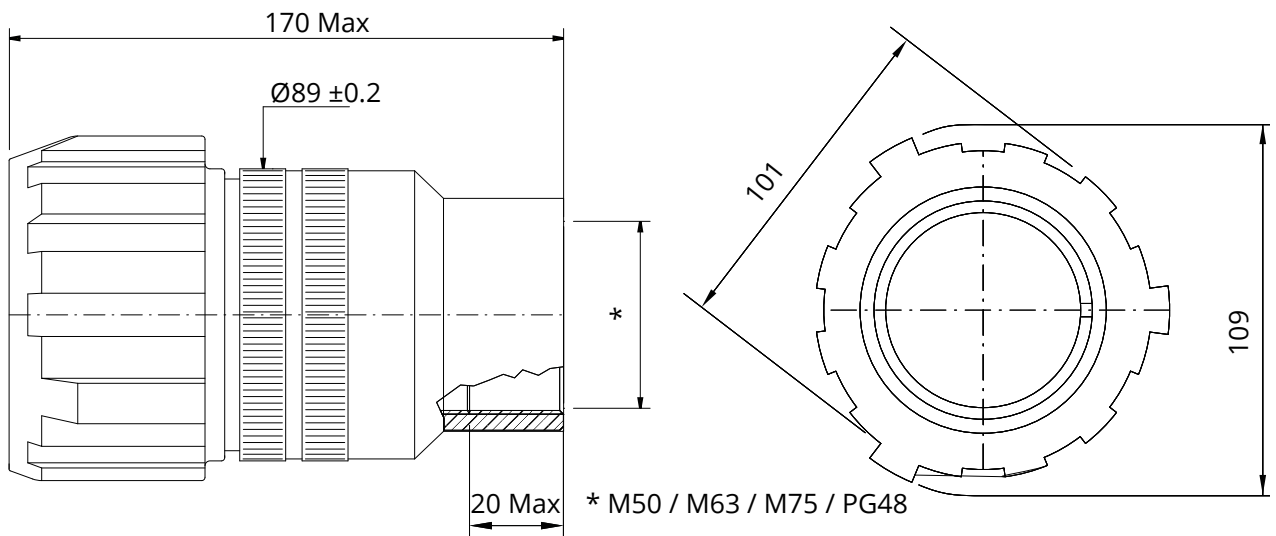

Inserts Arrangement	Insert Material	Contacts Type	N. Total Contacts	Contacts Size/Current Rating								Service Rating Code
				4/0 225A	0 150A	4 80A	8 46A	12 23A	16 13A	18 7.5A	20 7.5A	
● 48A4	Thermoplastic	KT	4	4								D (1250 Vdc - 900 Vac)
48A7	Thermoplastic	KT	6	4			2					A (700 Vdc - 500 Vac)
48-6	Rubber	ST	6	3				3				A (700 Vdc - 500 Vac)
48A9	Rubber	ST	9	3	2			4				(PD4 OV3) 400V
48A58	Rubber	ST	58				1	57				A (700 Vdc - 500 Vac)
48A101	Rubber	ST	101						101			A (700 Vdc - 500 Vac)

● Grommet Available

Dimensions in mm

Dimension "L" can be different from the value indicated according to backshells accessories, wires size and some special insert configurations.

GVJ - Oversize Bayonet Connector

RF	GVJ		06	DA	T	48-6	S	X	M12	CR	CD5	F7		N
	Series Code		Shell Type	Connector Class					Backshell internal thread			Shell finish		

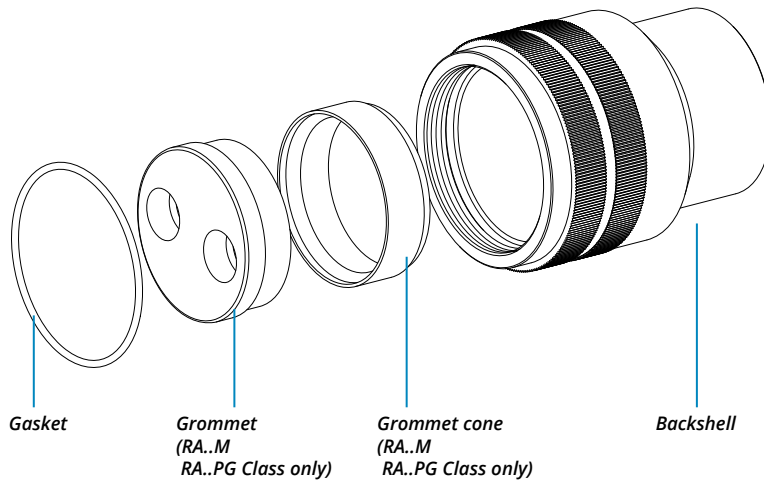

RF	Insulating material	-	Chloroprene rubber or thermoplastic Inserts ****	S	Contact Gender	S	Socket contacts
		RF	Fire resistant rubber			P	Pin contacts
GVJ	Series Code	GVJ	Oversize Bayonet Connector with protected mating ramps	X	Polarization Code**		Alternate Positions
	Shell Material	-	Aluminum	M12	Backshell internal thread	M	Provided with an internal Metric thread
06	Shell Type	06	Plug Connector			PG	Provided with an internal PG thread
DA	Connector Class	DA	with waterproof O-ring (IP67***)	CR	Contact Termination	-	Solder contacts
T		Connector Modification**	T			With plastic caps	CR
48-6	Insert Arrangement		Size - Type			LC	Less contacts
				CD5	Contact Plating	-	Silver plating
						CD5	Gold plating
						F7	Black epoxy varnish (*)
				F7	Shell finish	F16	CCF - Black passivation (*) - conductive
						F26	hard anodization (*)
						N	Modification Code**
				S			

**** Other insulating parts in fire resistant rubber

*** Protection degree: IP 67 (only in the mating area with mated connectors) according to EN 60529 (*) RoHS compliance (**) If required

P/N Sample: RF GVJ 06DAT 48-6SX M12 CR CD5 F7 N

GVJ - Oversize Bayonet Connector

Plug Connector with rubber covered coupling nut (08) with 90° Elbow Class (A - DA - RA)

Connector with 90° elbow provided with an external thread suitable for MS3057...A or C type Cable-Clamps (to be ordered separately). Rubber covered coupling nut able to protect against dust and impact; protected mating ramps.

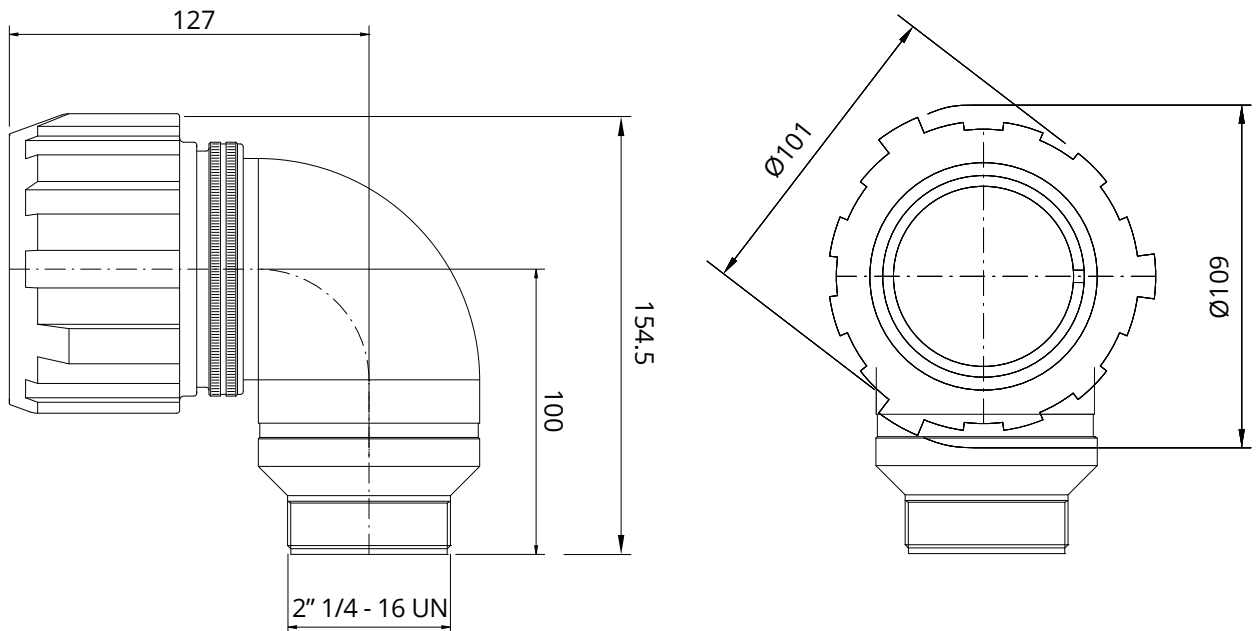

Inserts Arrangement	Insert Material	Contacts Type	N. Total Contacts	Contacts Size/Current Rating								Service Rating Code
				4/0 225A	0 150A	4 80A	8 46A	12 23A	16 13A	18 7.5A	20 7.5A	
● 48A4	Thermoplastic	KT	4	4								D (1250 Vdc - 900 Vac)
48A7	Thermoplastic	KT	6	4			2					A (700 Vdc - 500 Vac)
48-6	Rubber	ST	6	3				3				A (700 Vdc - 500 Vac)
48A9	Rubber	ST	9	3	2			4				(PD4 OV3) 400V
48A58	Rubber	ST	58				1	57				A (700 Vdc - 500 Vac)
48A101	Rubber	ST	101							101		A (700 Vdc - 500 Vac)

● Grommet Available

Dimensions in mm

Dimension "L" can be different from the value indicated according to backshells accessories, wires size and some special insert configurations.

GVJ - Oversize Bayonet Connector

RF	GVJ		08	DA	T	48-6	S	X		CR	CD5	F7		N
	Series Code		Shell Type	Connector Class								Shell finish		

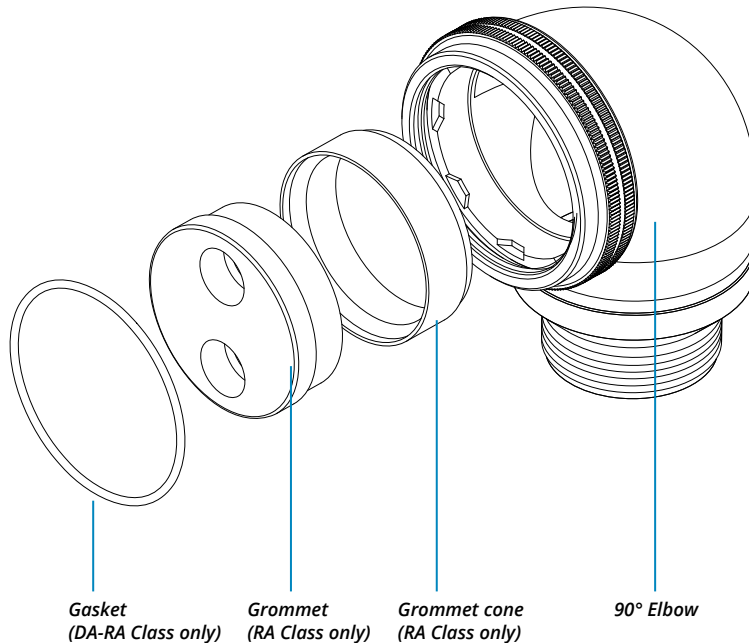

RF	Insulating material	-	Chloroprene rubber or thermoplastic Inserts ****	48-6	Insert Arrangement	Size - Type	
		RF	Fire resistant rubber				
GVJ	Series Code	GVJ	Oversize Bayonet Connector with protected mating ramps	S	Contact Gender	S	Socket contacts
						P	Pin contacts
	Shell Material	-	Aluminum	X	Polarization Code**		Alternate Positions
08	Shell Type	08	Plug Connector with 90° elbow	CR	Contact Termination	-	Solder contacts
		A	non watertight			CR	Crimp contacts
DA	Connector Class	DA	with waterproof O-ring (IP67****)			LC	Less contacts
		RA	with waterproof O-ring and grommet (IP67****) (#)	CD5	Contact Plating	-	Silver plating
T	Connector Modification**	T	With plastic caps	F7	Shell finish	F7	Black epoxy varnish (*)
						F16	CCF - Black passivation (*) - conductive
				N	Modification Code**	N	Consult our sales office
						S	

**** Other insulating parts in fire resistant rubber

*** Protection degree: IP 67 (only in the mating area with mated connectors) according to EN 60529 (*) RoHS compliance (***) If required

P/N Sample: RF GVJ 08DAT 48-6SX CR CD5 F7 N

GVJ - Oversize Bayonet Connector

Plug Connector with rubber covered coupling nut (08) with 90° Elbow Class (AC - ACF)

Connector with 90° elbow provided with MS3057...C type Cable-Clamp (for jacketed cable)
 Rubber covered coupling nut able to protect against dust and impact; protected mating ramps.

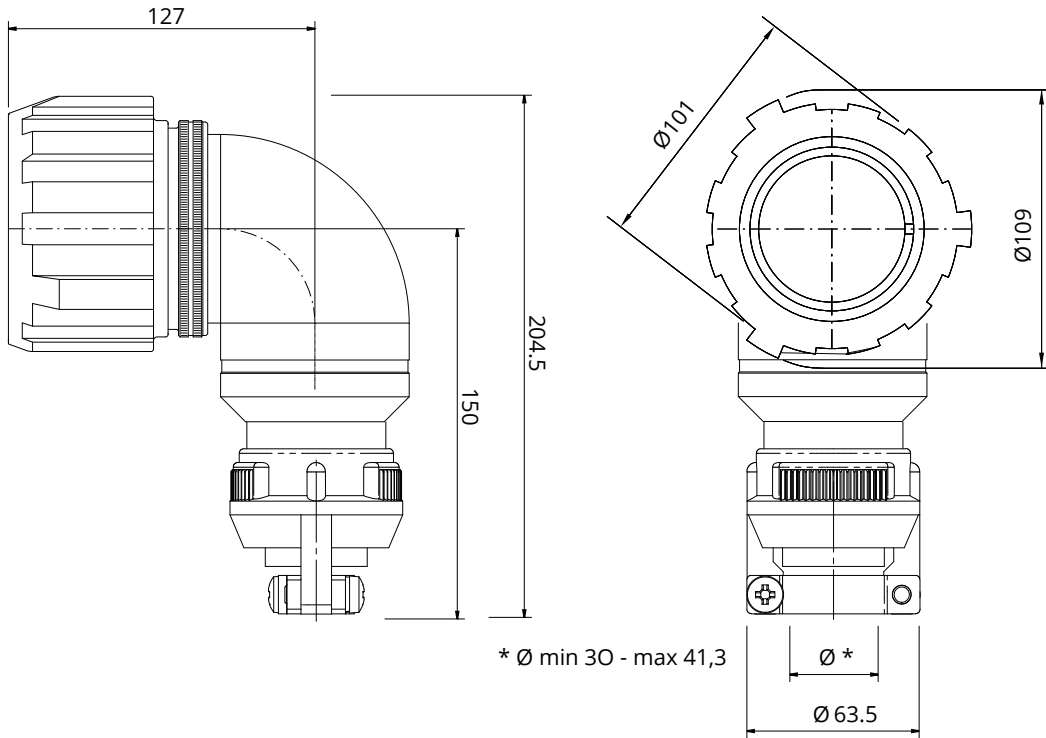

Inserts Arrangement	Insert Material	Contacts Type	N. Total Contacts	Contacts Size/Current Rating								Service Rating Code
				4/0 225A	0 150A	4 80A	8 46A	12 23A	16 13A	18 7.5A	20 7.5A	
● 48A4	Thermoplastic	KT	4	4								D (1250 Vdc - 900 Vac)
48A7	Thermoplastic	KT	6	4			2					A (700 Vdc - 500 Vac)
48-6	Rubber	ST	6	3				3				A (700 Vdc - 500 Vac)
48A9	Rubber	ST	9	3	2			4				(PD4 OV3) 400V
48A58	Rubber	ST	58				1	57				A (700 Vdc - 500 Vac)
48A101	Rubber	ST	101						101			A (700 Vdc - 500 Vac)

● Grommet Available

Dimensions in mm

Dimension "L" can be different from the value indicated according to backshells accessories, wires size and some special insert configurations.

GVJ - Oversize Bayonet Connector

RF	GVJ		08	ACF	T	48-6	S	X		CR	CD5	F7		N
Series Code	Shell Type	Connector Class										Shell finish		

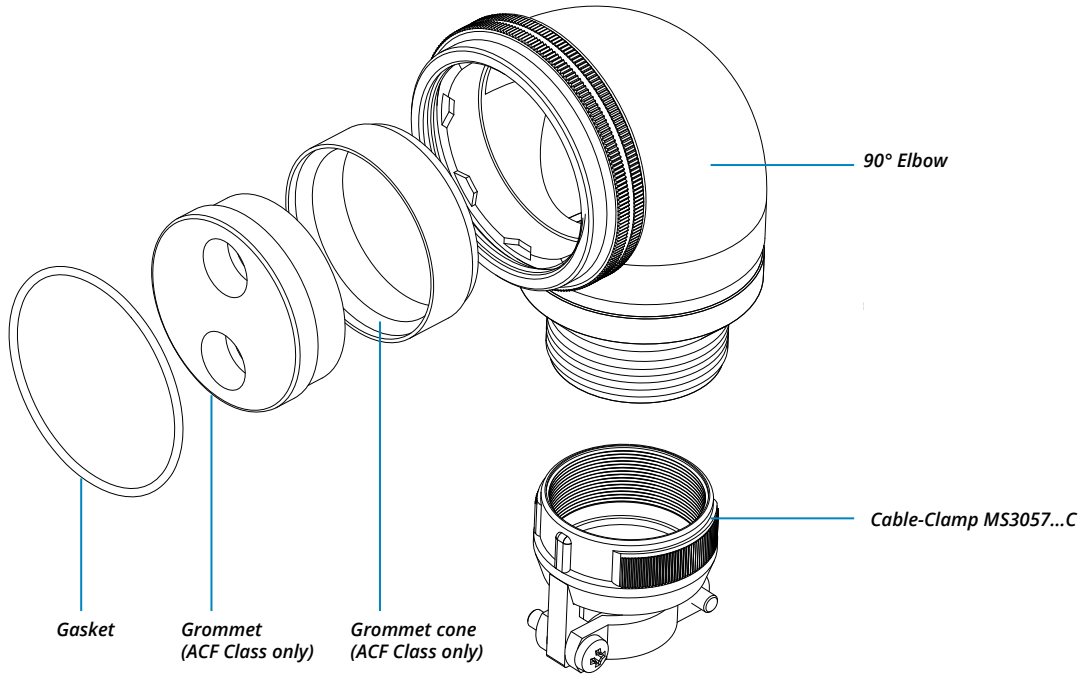

RF	Insulating material	-	Chloroprene rubber or thermoplastic Inserts ****	48-6	Insert Arrangement		Size - Type
GVJ	Series Code	GVJ	Oversize Bayonet Connector with protected mating ramps	S	Contact Gender	S	Socket contacts
	Shell Material	-	Aluminum	P		P	Pin contacts
08	Shell Type	08	Plug Connector with 90° elbow	X	Polarization Code**		Alternate Positions
ACF	Connector Class	AC	with waterproof O-ring (IP67)	CR	Contact Termination	-	Solder contacts
T	Connector Modification**	T	With plastic caps	CR		CR	Crimp contacts
				LC		LC	Less contacts
				CD5	Contact Plating	-	Silver plating
				F7	Shell finish	F7	Black epoxy varnish (*)
				F16		F16	CCF - Black passivation (*) - conductive
				N	Modification Code**	N	Consult our sales office
				S		S	

**** Other insulating parts in fire resistant rubber

P/N Sample: RF GVJ 08ACFT 48-6SX CR CD5 F7 N

(*) RoHS compliance

(**) If required

GVJ - Oversize Bayonet Connector

Plug Connector with rubber covered coupling nut (08) with 90° Elbow Class (DA...M - RA...M)

Connector with 90° elbow provided with an internal Metric or PG thread suitable for Cable Glands or conduit adapters. Rubber covered coupling nut able to protect against dust and impact; protected mating ramps.

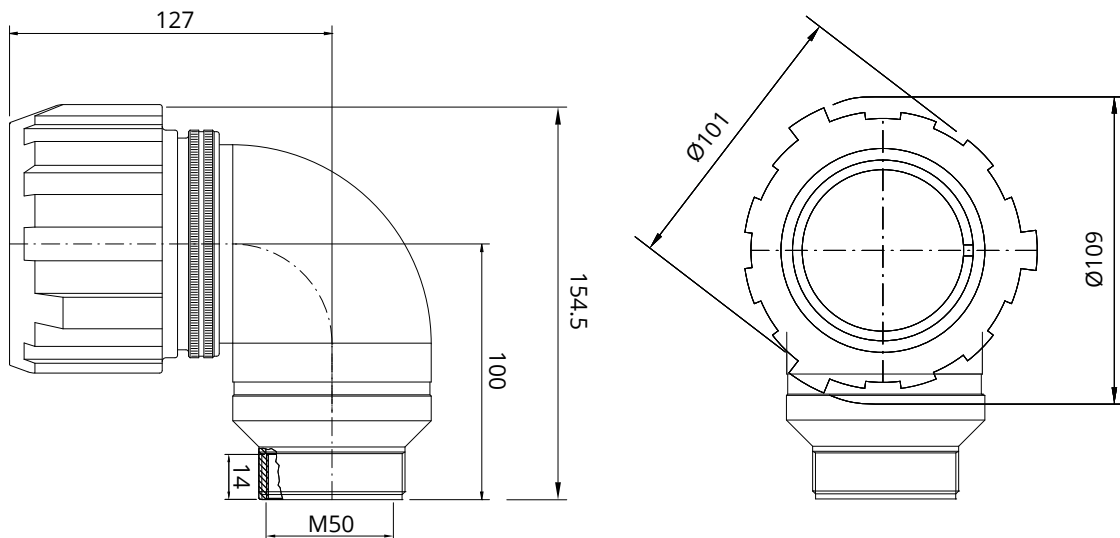

Inserts Arrangement	Insert Material	Contacts Type	N. Total Contacts	Contacts Size/Current Rating								Service Rating Code
				4/0 225A	0 150A	4 80A	8 46A	12 23A	16 13A	18 7.5A	20 7.5A	
● 48A4	Thermoplastic	KT	4	4								D (1250 Vdc - 900 Vac)
48A7	Thermoplastic	KT	6	4			2					A (700 Vdc - 500 Vac)
48-6	Rubber	ST	6	3				3				A (700 Vdc - 500 Vac)
48A9	Rubber	ST	9	3	2			4				(PD4 OV3) 400V
48A58	Rubber	ST	58				1	57				A (700 Vdc - 500 Vac)
48A101	Rubber	ST	101							101		A (700 Vdc - 500 Vac)

● Grommet Available

Dimensions in mm

Dimension "L" can be different from the value indicated according to backshells accessories, wires size and some special insert configurations.

GVJ - Oversize Bayonet Connector

RF	GVJ		08	DA	T	48-6	S	X	M50	CR	CD5	F7		N
Series Code	Shell Type	Connector Class	Backshell internal thread	Shell finish										

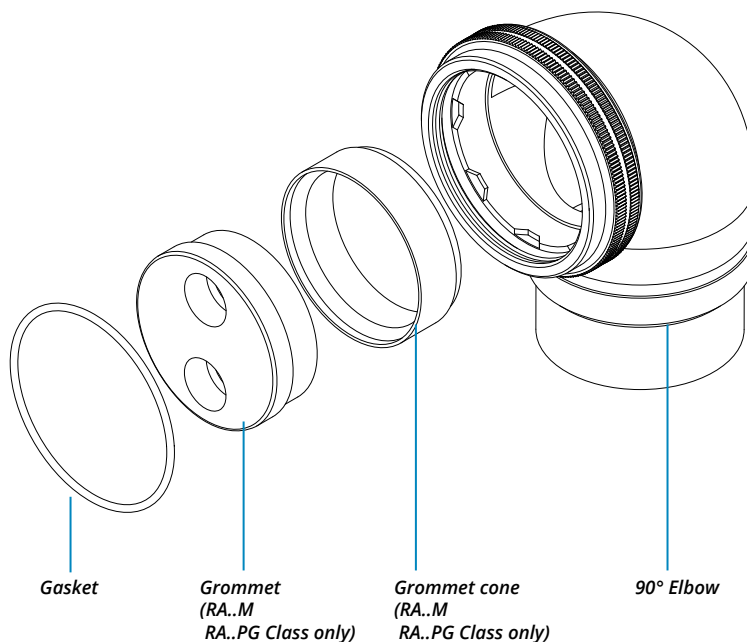

RF	Insulating material	-	Chloroprene rubber or thermoplastic Inserts ****
		RF	Fire resistant rubber
GVJ	Series Code	GVJ	Oversize Bayonet Connector with protected mating ramps
	Shell Material	-	Aluminum
08	Shell Type	08	Plug Connector with 90° elbow
DA	Connector Class	DA	with waterproof O-ring (IP67***)
		RA	with waterproof O-ring and grommet (IP67***)
T	Connector Modification**	T	With plastic caps
48-6	Insert Arrangement		Size - Type

S	Contact Gender	S	Socket contacts
		P	Pin contacts
X	Polarization Code**		Alternate Positions
M50	Backshell internal thread	M	Provided with an internal Metric thread
		PG	Provided with an internal PG thread
CR	Contact Termination	-	Solder contacts
		CR	Crimp contacts
		LC	Less contacts
CD5	Contact Plating	-	Silver plating
		CD5	Gold plating
F7	Shell finish	F7	Black epoxy varnish (*)
		F16	CCF - Black passivation (*) - conductive
N	Modification Code**	N	Consult our sales office
		S	

**** Other insulating parts in fire resistant rubber

*** Protection degree: IP 67 (only in the mating area with mated connectors) according to EN 60529 (*) RoHS compliance (**) If required

P/N Sample: RF GVJ 08DAT 48-6SX M50 CR CD5 F7 N

GVJG - Oversize Bayonet Connector with external insulated coating

Plug Connector with rubber covered coupling nut (06) with Backshell Class (DA..M - RA..M)

Connector with backshell provided with an internal Metric thread suitable for Cable Glands or conduit adapters. Rubber covered coupling nut able to protect against dust and impact; protected mating ramps.

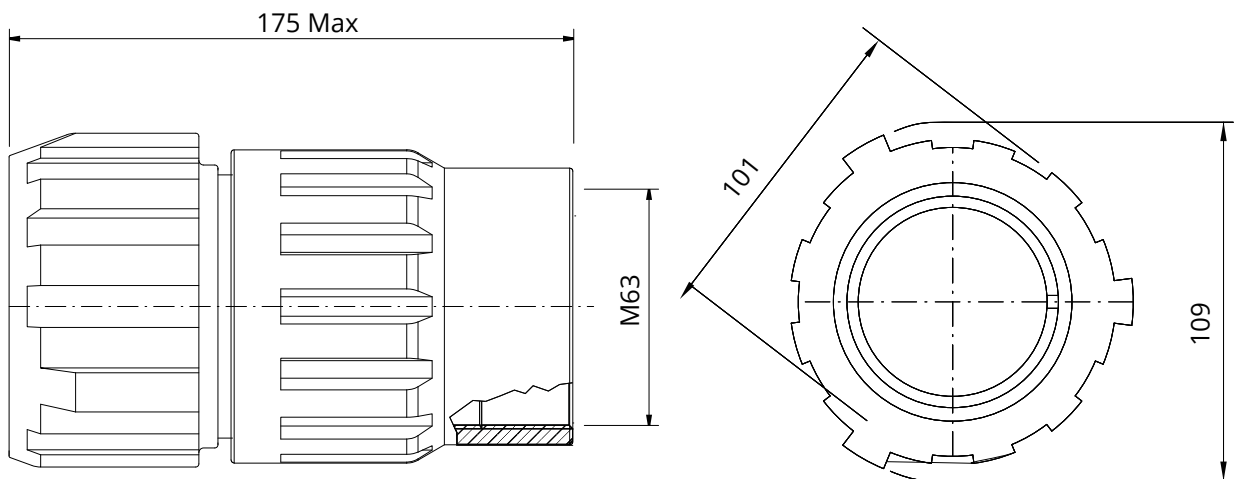

Inserts Arrangement	Insert Material	Contacts Type	N. Total Contacts	Contacts Size/Current Rating								Service Rating Code
				4/0 225A	0 150A	4 80A	8 46A	12 23A	16 13A	18 7.5A	20 7.5A	
● 48A4	Thermoplastic	KT	4	4								D (1250 Vdc - 900 Vac)
48A7	Thermoplastic	KT	6	4			2					A (700 Vdc - 500 Vac)
48-6	Rubber	ST	6	3				3				A (700 Vdc - 500 Vac)
48A9	Rubber	ST	9	3	2			4				(PD4 OV3) 400V
48A58	Rubber	ST	58				1	57				A (700 Vdc - 500 Vac)
48A101	Rubber	ST	101							101		A (700 Vdc - 500 Vac)

● *Grommet Available*

Dimensions in mm

Dimension "L" can be different from the value indicated according to backshells accessories, wires size and some special insert configurations.

GVJG - Oversize Bayonet Connector with external insulated coating

RF	GVJG		06	DA	T	48-6	S	X	M63	CR	CD5	F7		N
Series Code	Shell Type	Connector Class							Backshell internal thread			Shell finish		

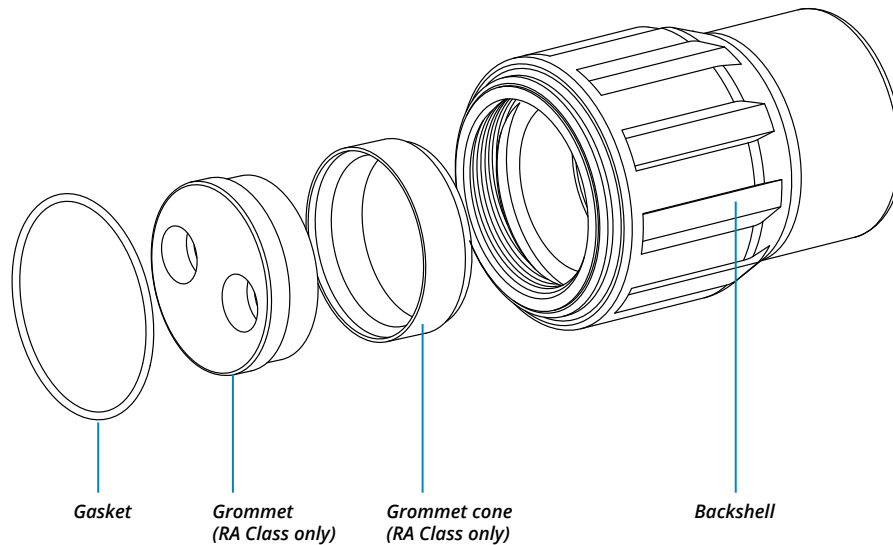

RF	Insulating material	-	Chloroprene rubber or thermoplastic Inserts ****	S	Contact Gender	S	Socket contacts
		RF	Fire resistant rubber			P	Pin contacts
GVJG	Series Code	GVJG	Oversize Bayonet Connector with protected mating ramps and external insulated coating	X	Polarization Code**		Alternate Positions
	Shell Material	-	Aluminum	M63	Backshell internal thread	M	Provided with an internal Metric thread
06	Shell Type	06	Plug Connector	CR	Contact Termination	-	Solder contacts
						CR	Crimp contacts
						LC	Less contacts
DA	Connector Class	DA	with waterproof O-ring (IP67***)	CD5	Contact Plating	-	Silver plating
		RA	with waterproof O-ring and grommet (IP67***)			CD5	Gold plating
						F7	Black epoxy varnish (*)
T	Connector Modification**	T	With plastic caps	F7	Shell finish	F16	CCF - Black passivation (*) - conductive
						F26	hard anodization (*)
48-6	Insert Arrangement		Size - Type	N	Modification Code**	N	Consult our sales office
						S	

**** Other insulating parts in fire resistant rubber

*** Protection degree: IP 67 (only in the mating area with mated connectors) according to EN 60529 (*) RoHS compliance (**) If required

P/N Sample: RF GVJG 06DAT 48-6SX M63 CR CD5 F7 N

Connector Shell - Receptacle mounting holes option

The front/rear mounting panel connectors as well as through-bulkhead connectors and dummy receptacles can be also supplied with different mounting holes. Please refer to the dimensional tables below.



FF	Connector Modification	FF	Receptacle connector with threaded holes (to specify for 00/02/020/05 shell only)
		FP	Receptacle connector with through holes (to specify for 03/030/038/TB shell only)
		FS	Receptacle connector with countersunk holes

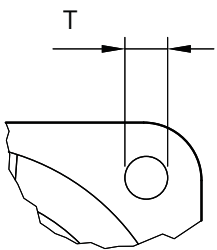
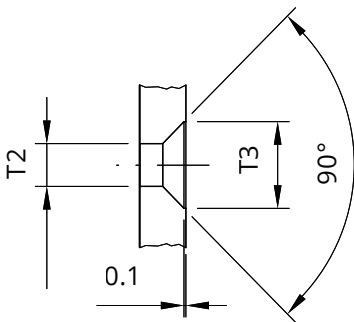
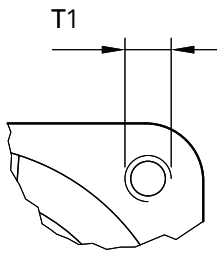

Shell size

Front mounting panel connectors Shell version: 00 - 020 - 02 - 05

Shell size	Threaded holes	Countersunk holes		Through holes
	FF T1	FS T2	T3	Standard Version T
10SL	M4	3.2	6.5	3.1
14S	M4	3.2	6.5	3.1
16S	M4	3.2	6.5	3.1
16	M4	3.2	6.5	3.1
18	M4	3.2	6.5	3.1
20	M4	3.2	6.5	3.1
22	M4	3.2	6.5	3.1
24	M5*	3.7	7.5	3.7
28	M5	3.7	7.5	3.7
32	M5	4.3	8	4.4
36	M5	4.3	8.5	4.4
40	M5	4.3	8.5	4.4
GVJ	-	-	-	8.5

* M5 front mounting panel, M4 Real mounting panel

Shell size

Rear mounting panel connectors Shell version: 03 - 030 - 038 - TB

Shell size	Through holes	Threaded holes	Threaded holes	Through holes
	FP - T	Standard Version T1	holes FF - T1	Standard Version T
10SL	3.2	M4	-	-
14S	3.2	M4	-	-
16S	3.2	M4	-	-
16	3.2	M4	-	-
18	3.2	M4	-	-
20	3.2	M4	-	-
22	3.2	M4	-	-
24	3.7	M4*	-	-
28	3.7	M5	-	-
32	4.3	M5	-	-
36	4.3	M5	-	-
40	4.3	M5	-	-
GVJ	-	-	M8	8.5

Dimensions in mm

Connector Shell - Panel drilling dimensions

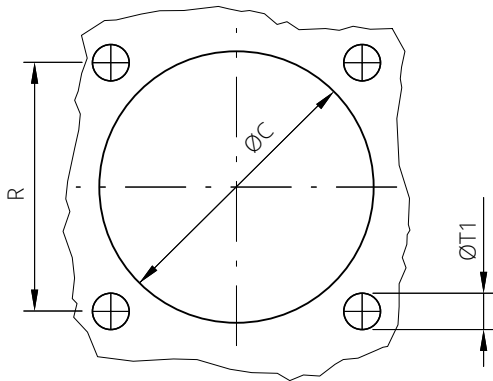

Panel cut out

Shell size	R	Shell version: 00 - 020 - 02 *			Shell version: 03 - 030 - 038 - TB		
		ØC ±0.2	ØT1 for FP Through holes (standard hole) and FS Countersunk holes	ØT1 for FF Threaded holes	ØC ±0.2	ØT1 for FF Threaded holes (standard hole)	ØT1 for FP Through holes
10SL	18.2	17	3.4	4.5	19.1	4.5	3.4
14S	23	20	3.4	4.5	25.5	4.5	3.4
16S	24.6	23	3.4	4.5	28.3	4.5	3.4
16	24.6	23	3.4	4.5	28.3	4.5	3.4
18	27	26.5	3.4	4.5	31.7	4.5	3.4
20	29.4	30	3.4	4.5	35	4.5	3.4
22	31.8	33	3.4	4.5	38.3	4.5	3.4
24	34.9	36	3.9	5.5	41.8	4.5	3.9
28	39.7	42	3.9	5.5	47.6	5.5	3.9
32	44.5	48.5	4.5	5.5	54.3	5.5	4.5
36	49.2	55	4.5	5.5	60.5	5.5	4.5
40	55.6	61	4.5	5.5	66.4	5.5	4.5
GVJ	90	76	9	-	91.8	8.5 (on request)	9 (standard)

* For use with backshell mounted and accessories, consult our sales office.

Shell size	Shell version: 07 - 070 - 078	
	ØC -0 +0.25	A +0 -0.35
10SL	22.4	21
14S	28.75	27.4
16S	31.95	30.95
16	31.95	30.95
18	35.1	33.75
20	38.3	36.85
22	41.45	40.05
24	44.65	43.35
28	51	49.55
32	57.35	55.95
36	63.7	62.35
40	70.05	68.55

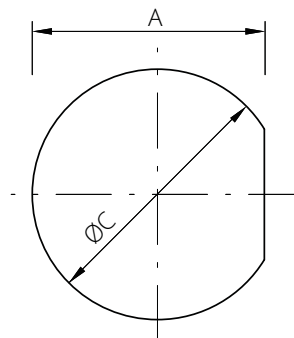

Panel cut out

If required the nut can be lock with optional screws

Dimensions in mm

Connector Shell - Mounting panel characteristics

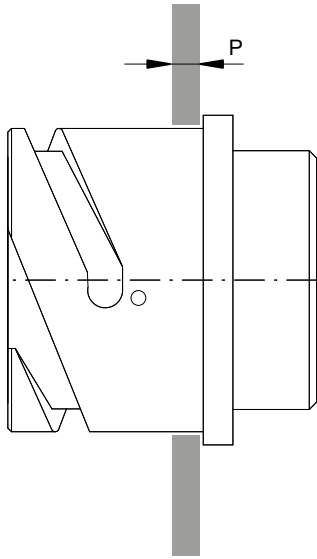

Shell size	P Panel Thickness *			
	Shell version: 03 - 030 - 038 Rear Mounting Panel Connectors	Shell version: 07 - 070 - 078 Jam Nut Rear Mounting Panel Connectors		Shell version: TB Through bulkhead, gasket side mounting connectors
	Max	Min	Max	Max
10SL	6	2.4	5.2	10
14S	7.2	2.7	7.5	9.6
16S	7.2	2.4	7.5	9.6
16	5.35	2.4	7.5	13.8
18	7.25	2.4	9	13
20	7.3	2.4	8.1	13
22	7.3	2.4	9.1	12.25
24	6.85	2.4	9.1	11.25
28	7.8	2.4	8.5	12.4
32	7.5	2.4	6.5	9
36	7.5	2.4	8.3	8.3
40	7.5	2.4	8.3	9
GVJ	10	-	-	-

* For use with no rubber covered nut

For use with shell type GG coupling nut rubber covered (or shell type 61 or 81), please consult our sales office.

Dimensions in mm

Contacts - Part number explanation



P/N Sample: ST485 16-13S CD5

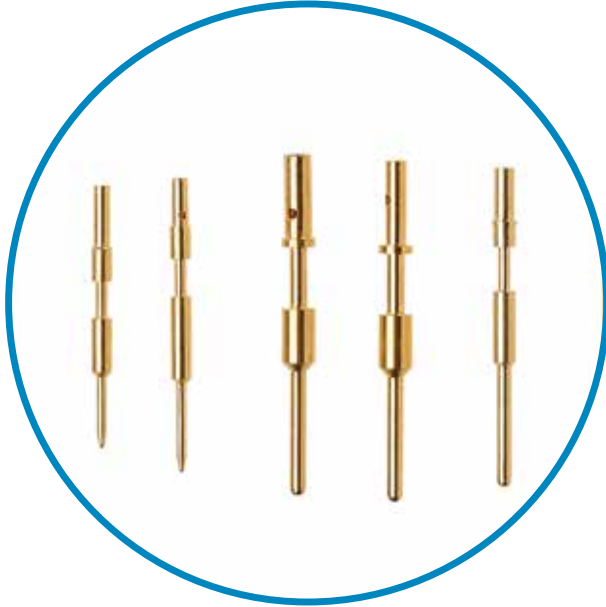

Contact	AWG	Rated Current**
20	26	2A
20	24	3A
20	22	5A
20	20	7,5A
18	20	10A
16	20	7,5A
16	18	10A
16	16	13A
16	12	13A
12	20	7,5A
12	18	7,5A
12	16	13A
12	14	17A
12	12	23A
8	16	13A
8	12	23A
8	10	33A
8	8	46A
4	10	33A
4	6	60A
4	4	80A
0	8	46A
0	2	100A
0	0	150A
4/0	0	150A
4/0	4/0	225A

** Valid for ambient temperature at 80°C

ST	Contact Type	ST	Contact for rubber insert
		KT	Contact for thermoplastic insert
		CC	Coaxial contact
		TC1 - TC2 - TC3 - TC4	Contact for thermocouple
485	Contact Termination	385	Solder
		485	Crimp
		585	For Lug
XX	Contact Size #	xx	Contact size
L	Connection type	L	With Louver
XX	Non-standard diameter	xx	For special wires
S	Contact Gender	S	Socket
		P	Pin
CLE	Variation	TP	Touch Proof
		CLE	Close Entry
		FM	FMLB (long contacts)
		AO	Advance opening (short contacts)
CD5	Contact Plating	-	Silver Plated
		CD5	Gold Plated
N_	Modification Code	Nxx	Modification Code

The creepage distance is reduced for the insert with contacts for larger wires than the standard ones. Consult our commercial office for Service Rating. The contacts with reduced ØD for smaller wire may be a sealing problem with grommets. The contacts with enlarged ØD for larger wires may be difficulties with grommets. Please contact our sales office.

Solder Contacts - ST - For Rubber insert

Pin Contacts - Silver Plated

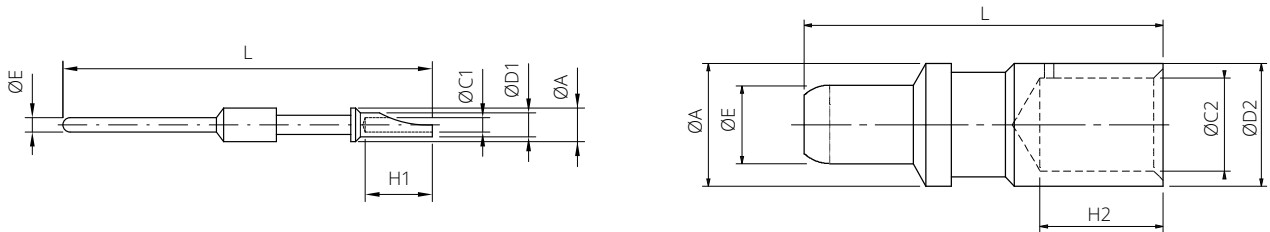

Contact size	Part Number	Short Description	AWG Cable size	ØA	ØE	ØC1	ØC2	ØD1	ØD2	H1	H2	L
16S	VS702001	ST385 16SP	18+16	3.2	1.58	1.8	-	2.6	-	5.5	-	25.7
16	VS702002	ST385 16P	18+16	3.2	1.58	1.8	-	2.6	-	7	-	32.1
12	VS702003	ST385 12P	12	4.8	2.38	2.9	-	3.7	-	8	-	36.6
8	VS702004	ST385 8P	8	7.8	3.6	-	5.3	-	6.6	-	12.6	36.6
4	VS702005	ST385 4P	4	11	5.7	-	8.5	-	10	-	16.5	36.6
0	VS702006	ST385 0P	0	15.1	9.05	-	11.5	-	14	-	14	44.5

Socket Contacts - Silver Plated

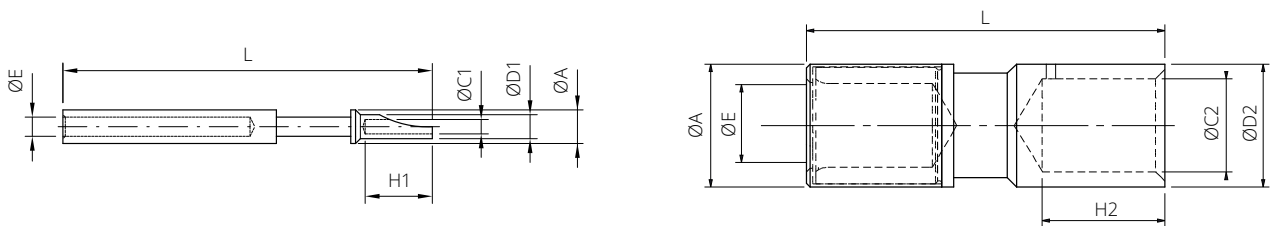

Contact size	Part Number	Short Description	AWG Cable size	ØA	ØE	ØC1	ØC2	ØD1	ØD2	H1	H2	L
16S	VS702011	ST385 16SS	18+16	3.2	1.65	1.8	-	2.6	-	5.5	-	25.4
16	VS702012	ST385 16S	18+16	3.2	1.65	1.8	-	2.6	-	7	-	36.6
12	VS702013	ST385 12S	12	4.8	2.48	2.9	-	3.7	-	8	-	36.6
8	VS702014	ST385 8S	8	7.8	3.7	-	5.25	-	6.55	-	12.7	36.6
4	VS702015	ST385 4S	4	11	5.8	-	8.5	-	10	-	12	36.6
0	VS702016	ST385 0S	0	15.1	9.17	-	11.5	-	14	-	14	44.5

Dimensions in mm

Solder Contacts - ST - For Rubber insert

Pin Contacts - Gold Plated

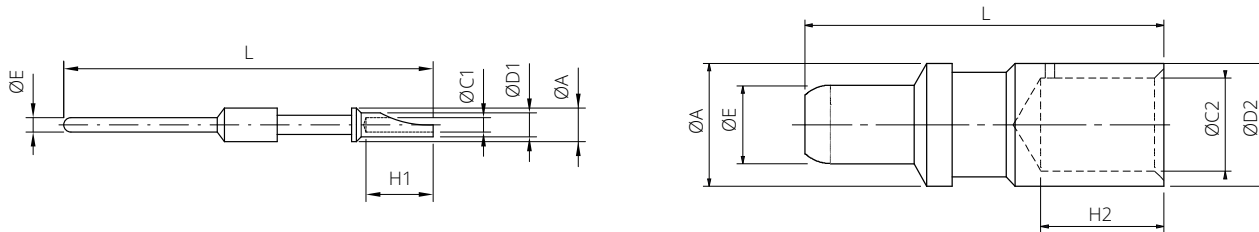

Contact size	Part Number	Short Description	AWG Cable size	ØA	ØE	ØC1	ØC2	ØD1	ØD2	H1	H2	L
16S	VS702021	ST385 16SP CD5	18÷16	3.2	1.58	1.8	-	2.6	-	5.5	-	25.7
16	VS702022	ST385 16P CD5	18÷16	3.2	1.58	1.8	-	2.6	-	7	-	32.1
12	VS702023	ST385 12P CD5	12	4.8	2.38	2.9	-	3.7	-	8	-	36.6
8	VS702024	ST385 8P CD5	8	7.8	3.6	-	5.3	-	6.6	-	12.6	36.6
4	VS702025	ST385 4P CD5	4	11	5.7	-	8.5	-	10	-	16.5	36.6
0	VS702026	ST385 0P CD5	0	15.1	9.05	-	11.5	-	14	-	14	44.5

Socket Contacts - Gold Plated

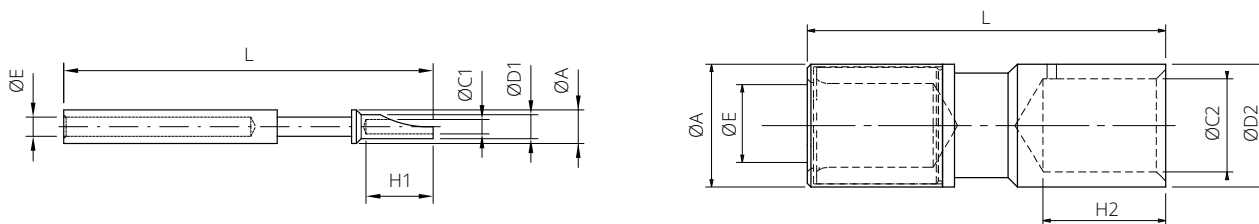

Contact size	Part Number	Short Description	AWG Cable size	ØA	ØE	ØC1	ØC2	ØD1	ØD2	H1	H2	L
16S	VS702031	ST385 16SS CD5	18÷16	3.2	1.65	1.8	-	2.6	-	5.5	-	25.4
16	VS702032	ST385 16S CD5	18÷16	3.2	1.65	1.8	-	2.6	-	7	-	36.6
12	VS702033	ST385 12S CD5	12	4.8	2.48	2.9	-	3.7	-	8	-	36.6
8	VS702034	ST385 8S CD5	8	7.8	3.7	-	5.25	-	6.55	-	12.7	36.6
4	VS702035	ST385 4S CD5	4	11	5.8	-	8.5	-	10	-	12	36.6
0	VS702036	ST385 0S CD5	0	15.1	9.17	-	11.5	-	14	-	14	44.5

Dimensions in mm

Crimp Contacts - ST - For Rubber insert

Pin Contacts - Silver Plated

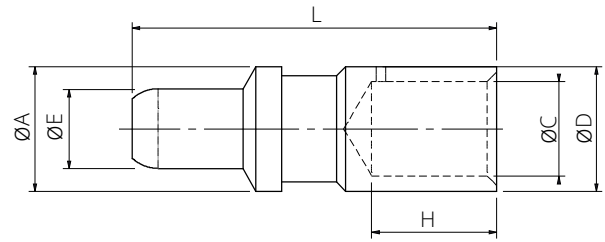
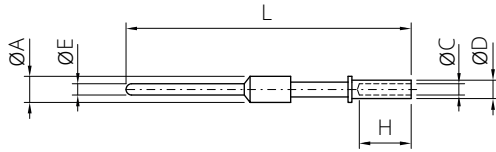

Contact Size	Part Number	Short Description	Wire section (mm ²)	AWG cable size	ØA	ØE	ØC	ØD	H	L
20	VS701600	ST485 20P/1(a)**	0.15±0.3	26÷22	2	1	0.9	1.6	4	32.5
20	VS701601	ST485 20P/2(b)**	0.15±0.3	26÷22	2	1	0.9	1.6	4	24.6
20	VS701602	ST485 20P/3(C)**	0.15±0.3	26÷22	2	1	0.9	1.6	4	29.9
18	VS701603	ST485 18P	0.15±0.6	26÷20	2.2	1.42	1.3	1.93	4.5	29.6
16S	VS701604	ST485 16SP	1÷1.5	18÷16	3.2	1.58	1.7	2.6	6.5	26.6
● 16S	VS701655	ST485 16S-11P #	0.25±0.5	22-20	3.2	1.58	1.1	2.15	6.5	26.6
16S	VS701605	ST485 16S-12P #	0.15±0.75	20	3.2	1.58	1.2	2.6	6.5	26.6
16S	VS701607	ST485 16S-15P #	0.75±1	18	3.2	1.58	1.5	2.6	6.5	26.6
● 16S	VS701656	ST485 16S-17P #	0.75	-	3.2	1.58	1.75	2.62	6.5	26.6
16S	VS701608	ST485 16S-20P #	1÷2	18÷14	3.2	1.58	2	2.9	6.5	26.6
16S	VS701609	ST485 16S-26P #	2.5÷3	12	3.2	1.58	2.5	3.8	7	27
16	VS701610	ST485 16P	1÷1.5	18÷16	3.2	1.58	1.7	2.6	6.5	31.75
16	VS701611	ST485 16-08P** #	0.15±0.2	26÷24	3.2	1.58	0.85	1.55	6.35	31.75
16	VS701612	ST485 16-12P #	0.15±0.75	20	3.2	1.58	1.2	2.6	6.35	31.75
16	VS701613	ST485 16-13P #	0.15±0.6	26÷20	3.2	1.58	1.3	1.93	6.35	31.75
● 16	VS701659	ST485 16-14P #	0.75	18	3.2	1.58	1.35	2.2	6.4	31.75
16	VS701614	ST485 16-15P #	0.75±1	18	3.2	1.58	1.5	2.6	6.35	31.75
16	VS701615	ST485 16-20P #	1÷2	18÷14	3.2	1.58	2	2.9	6.35	31.75
16	VS701616	ST485 16-26P #	2.5÷3	12	3.2	1.58	2.5	3.8	7	31.75
● 12	VS701657	ST485 12-11P #	0.5	22-20	4.8	2.38	1.1	3	8.5	37.5
12	VS701617	ST485 12-12P #	0.15±0.75	20	4.8	2.38	1.2	2.6	8.5	37.5
12	VS701618	ST485 12-15P #	0.75±1	18	4.8	2.38	1.5	3.4	8.5	37.5
12	VS701619	ST485 12-20P #	1÷2	18÷14	4.8	2.38	2	3.8	6.5	37.5
12	VS701620	ST485 12-22P #	2.5	-	4.8	2.38	2.2	3.8	8.5	37.5
12	VS701621	ST485 12P	3	12	4.8	2.38	2.5	3.8	8.5	37.5
12	VS701622	ST485 12-30P #	4	-	4.8	2.38	3	4.8	8.5	37.5
12	VS701623	ST485 12-38P #	6	-	4.8	2.38	3.6	4.8	8	37.5
8	VS701624	ST485 8P	-	8	7.8	3.6	4.55	6.8	12.2	40.7
8	VS701625	ST485 8-15P** #	1	18	7.8	3.6	1.5	3.4	8.5	40.7
8	VS701626	ST485 8-18P** #	1÷2	18÷14	7.8	3.6	1.8	3.8	8.5	40.7
● 8	VS701646	ST485 8-22P #	2.5	-	7.8	3.6	2.2	3.8	12.2	40.7
● 8	VS701647	ST485 8-26P #	3	12	7.8	3.6	2.5	3.8	12.2	40.7
8	VS701627	ST485 8-30P #	4	-	7.8	3.6	3	4.8	8.3	40.7
8	VS701628	ST485 8-38P #	6	10	7.8	3.6	3.6	6.8	12.2	40.6
8	VS701629	ST485 8-50P #	10	-	7.8	3.6	5	6.8	12.2	40.7
4	VS701630	ST485 4P	22	4	11	5.7	7.1	9.55	12.2	41.25
4	VS701631	ST485 4-26P** #	3	-	11	5.7	2.5	3.8	8.5	41.25
4	VS701632	ST485 4-30P** #	4	-	11	5.7	3	4.8	8.5	41.25
● 4	VS701648	ST485 4-38P #	6	10	11	5.7	3.6	6.8	12.2	41.25
4	VS701633	ST485 4-50P #	10	-	11	5.7	5	6.8	12.2	41.25
4	VS701634	ST485 4-58P #	-	6	11	5.7	5.8	7.8	12.2	41.25
4	VS701635	ST485 4-62P #	16	-	11	5.7	6.2	9.5	12.2	41.25
● 4	VS701649	ST485 4-78P #	25	-	11	5.7	7.8	9.55	12.2	41.25
● 4	VS701650	ST485 4-90P #	35	2	11	5.7	9	12	14	41.25
0	VS701636	ST485 0P	53	0	15.1	9.05	11.5	14.35	14.5	45
0	VS701637	ST485 0-45P #	-	8	15.1	9.05	4.55	6.8	12.2	44.5
● 0	VS701658	ST485 0-50P #	10	-	15.1	9.05	5	7	12.2	44.5
● 0	VS701651	ST485 0-58P #	-	6	15.1	9.05	5.8	7.8	14	44.5
● 0	VS701652	ST485 0-62P #	16	-	15.1	9.05	6.2	9.5	12.2	44.5
0	VS701638	ST485 0-78P #	25	-	15.1	9.05	7.8	9.5	14	44.5
● 0	VS701653	ST485 0-80P #	-	3	15.1	9.05	8	10	14	44.5
0	VS701639	ST485 0-90P #	35	2	15.1	9.05	9	14.35	13.6	44.5
0	VS701640	ST485 0-107P #	50	-	15.1	9.05	10.7	14.35	14.5	44.5
● 0	VS701654	ST485 0-135P #	67.4	2/0	15.1	9.05	13.5	16.5	18	51.9
● 4/0	VS701641	ST485 4/0-115P #	53	0	20	12.73	11.5	14.35	16.3	58.5
● 4/0	VS701642	ST485 4/0-135P #	67.4	2/0	20	12.73	13.5	16.5	18	58.5
● 4/0	VS701643	ST485 4/0-144P #	70	-	20	12.73	14.4	20	20	58.5
● 4/0	VS701644	ST485 4/0-155P #	95	-	20	12.73	15.2	19.7	20	58.5
● 4/0	VS701645	ST485 4/0P	107±120	4/0	20	12.73	15.2	19.7	20	58.5

● **New Contacts** ^(a) For arrangement 40A201 **** On request (please consult our Sales Office)** **Dimensions in mm**
^(b) For arrangements 24A55, 28-72, 32A101 and 28A31 **# See notes page "Contacts - Part number explanation" for contacts with**
^(c) For arrangement 22A24 **ØD different from standard**

Crimp Contacts - ST - For Rubber insert

Socket Contacts - Silver Plated

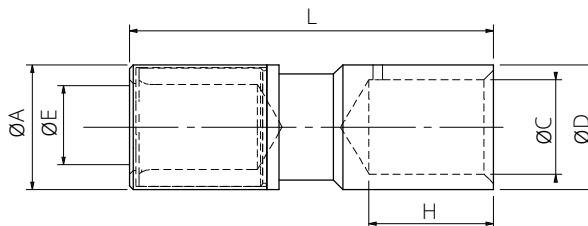
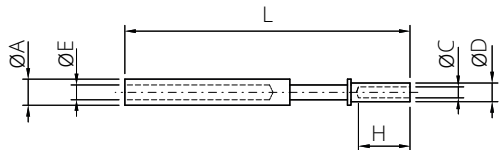

Contact Size	Part Number	Short Description	Wire section (mm²)	AWG cable size	ØA	ØE	ØC	ØD	H	L
-	-	-	-	-	-	-	-	-	-	-
18	VS701503	ST485 18S *	0.15÷0.6	26÷20	2.4	1.46	1.3	1.93	4.5	34.4
16S	VS701504	ST485 16S	1÷1.5	18÷16	3.2	1.68	1.7	2.6	6.35	27
● 16S	VS701555	ST485 16S-11S #	0.25÷0.5	22-20	3.2	1.68	1.1	2.15	6.5	26.6
16S	VS701505	ST485 16S-12S #	0.15÷0.75	20	3.2	1.68	1.2	2.6	6.5	26.6
16S	VS701507	ST485 16S-15S #	0.75÷1	18	3.2	1.68	1.5	2.6	6.5	26.6
● 16S	VS701556	ST485 16S-17S #	0.75	-	3.2	1.68	1.75	2.62	6.5	26.6
16S	VS701508	ST485 16S-20S #	1÷2	18÷14	3.2	1.68	2	2.9	6.5	27
16S	VS701509	ST485 16S-26S #	2.5÷3	12	3.2	1.68	2.5	3.8	7	27
16	VS701510	ST485 16S	1÷1.5	18÷16	3.2	1.68	1.7	2.6	6.5	36.5
16	VS701511	ST485 16-08S** #	0.15÷0.2	26÷24	3.2	1.68	0.85	1.55	6.35	36.5
16	VS701512	ST485 16-12S #	0.15÷0.75	20	3.2	1.68	1.2	2.6	6.5	36.5
16	VS701513	ST485 16-13S #	0.15÷0.6	26÷20	3.2	1.68	1.3	1.93	6.35	36.5
● 16	VS701559	ST485 16-14S #	0.75	18	3.2	1.68	1.35	2.2	6.4	36.5
16	VS701514	ST485 16-15S #	0.75÷1	18	3.2	1.68	1.5	2.6	6.5	36.5
16	VS701515	ST485 16-20S #	1÷2	18÷14	3.2	1.68	2	2.9	6.5	36.5
16	VS701516	ST485 16-26S #	2.5÷3	12	3.2	1.68	2.5	3.8	7	36.5
● 12	VS701557	ST485 12-11S #	0.5	22-20	4.8	2.48	1.1	3	8.5	37.5
12	VS701517	ST485 12-12S #	0.15÷0.75	20	4.8	2.48	1.2	2.6	8.5	37.5
12	VS701518	ST485 12-15S #	0.75÷1	18	4.8	2.48	1.5	3.4	8.5	37.5
12	VS701519	ST485 12-20S #	1÷2	18÷14	4.8	2.48	2	3.8	6.5	37.5
12	VS701520	ST485 12-22S #	2.5	-	4.8	2.48	2.2	3.8	8.5	37.5
12	VS701521	ST485 12S	3	12	4.8	2.48	2.5	3.8	8.5	37.5
12	VS701522	ST485 12-30S #	4	-	4.8	2.48	3	4.8	8.5	37.5
12	VS701523	ST485 12-38S #	6	-	4.8	2.48	3.6	4.8	8.5	37.5
8	VS701524	ST485 8S	-	8	7.8	3.7	4.55	6.8	12.2	40.7
8	VS701525	ST485 8-15S** #	1	18	7.8	3.7	1.5	3.4	8.5	40.7
8	VS701526	ST485 8-18S** #	1÷2	18÷14	7.8	3.7	1.8	3.8	8.5	40.7
● 8	VS701546	ST485 8-22S #	2.5	-	7.8	3.7	2.2	3.8	12.2	40.7
● 8	VS701547	ST485 8-26S #	3	12	7.8	3.7	2.5	3.8	12.2	40.7
8	VS701527	ST485 8-30S #	4	-	7.8	3.7	3	4.8	8.3	40.7
8	VS701528	ST485 8-38S #	6	10	7.8	3.7	3.6	6.8	12.2	40.7
8	VS701529	ST485 8-50S #	10	-	7.8	3.7	5	7	11.5	40.7
4	VS701530	ST485 4S	22	4	11	5.8	7.1	9.55	12.2	41.2
4	VS701531	ST485 4-26S** #	3	-	11	5.8	2.5	3.8	8.5	41.2
4	VS701532	ST485 4-30S** #	4	-	11	5.8	3	4.8	8.5	41.2
● 4	VS701548	ST485 4-38S #	6	10	11	5.8	3.6	6.8	12.2	41.2
4	VS701533	ST485 4-50S #	10	-	11	5.8	5	6.8	12.2	41.2
4	VS701534	ST485 4-58S #	-	6	11	5.8	5.8	7.8	12.2	41.2
4	VS701535	ST485 4-62S #	16	-	11	5.8	6.2	9.5	12.2	41.2
● 4	VS701549	ST485 4-78S #	25	-	11	5.8	7.8	9.5	12.2	41.2
● 4	VS701550	ST485 4-90S #	35	2	11	5.8	9	12	14	47
0	VS701536	ST485 0S	53	0	15.1	10.3	11.5	14.35	14.5	45
0	VS701537	ST485 0-45S #	-	8	15.1	10.3	4.55	6.8	12.7	45
● 0	VS701558	ST485 0-50S #	10	-	15.1	10.3	5	7	12.2	45
● 0	VS701551	ST485 0-58S #	-	6	15.1	10.3	5.8	7.8	14	45
● 0	VS701552	ST485 0-62S #	16	-	15.1	10.3	6.2	9.5	12.2	45
0	VS701538	ST485 0-78S #	25	-	15.1	10.3	7.8	9.5	14	45
● 0	VS701553	ST485 0-80S #	-	3	15.1	10.3	8	10	14	45
0	VS701539	ST485 0-90S #	35	2	15.1	10.3	9	14.35	14	45
0	VS701540	ST485 0-107S #	50	-	15.1	10.3	10.7	14.35	14.5	45
● 0	VS701554	ST485 0-135S #	67.4	2/0	15.1	10.3	13.5	16.5	18	52
● 4/0	VS701541	ST485 4/0-115S #	53	0	20	13.65	11.5	14.35	17	59
● 4/0	VS701542	ST485 4/0-135S #	67.4	2/0	20	13.65	13.5	16.5	18	59
● 4/0	VS701543	ST485 4/0-144S #	70	-	20	13.65	14.4	20	20	59
● 4/0	VS701544	ST485 4/0-155S #	95	-	20	13.65	15.2	19.7	20	59
● 4/0	VS701545	ST485 4/0S	107÷120	4/0	20	13.65	15.2	19.7	20	59

● New Contacts

② For all arrangements with contacts size 20 ** On request (please consult our Sales Office) Dimensions in mm

* Close entry contact type

See notes page "Contacts - Part number explanation" for contacts with ØD different from standard

Crimp Contacts - ST - For Rubber insert

Pin Contacts - Gold Plated

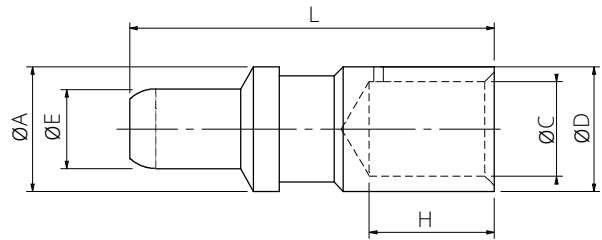
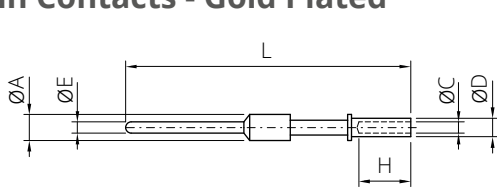

Contact Size	Part Number	Short Description	Wire section (mm²)	AWG cable size	ØA	ØE	ØC	ØD	H	L
20	VS701800	ST485 20P/1 CD5 (a)**	0.15÷0.3	26÷22	2	1	0.9	1.6	4	32.5
20	VS701801	ST485 20P/2 CD5 (b)**	0.15÷0.3	26÷22	2	1	0.9	1.6	4	24.6
20	VS701802	ST485 20P/3 CD5 (c)**	0.15÷0.3	26÷22	2	1	0.9	1.6	4	29.9
18	VS701803	ST485 18P CD5	0.15÷0.6	26÷20	2.2	1.42	1.3	1.93	4.5	29.6
16S	VS701804	ST485 16SP CD5	1÷1.5	18÷16	3.2	1.58	1.7	2.6	6.5	26.6
16S	VS701855	ST485 16S-11P CD5 #	0.25÷0.5	22-20	3.2	1.58	1.1	2.15	6.5	26.6
16S	VS701805	ST485 16S-12P CD5 #	0.15÷0.75	20	3.2	1.58	1.2	2.6	6.5	26.6
16S	VS701807	ST485 16S-15P CD5 #	0.75÷1	18	3.2	1.58	1.5	2.6	6.5	26.6
16S	VS701856	ST485 16S-17P CD5 #	0.75	-	3.2	1.58	1.75	2.62	6.5	26.6
16S	VS701808	ST485 16S-20P CD5 #	1÷2	18÷14	3.2	1.58	2	2.9	6.5	26.6
16S	VS701809	ST485 16S-26P CD5 #	2.5÷3	12	3.2	1.58	2.5	3.8	7	27
16	VS701810	ST485 16P CD5	1÷1.5	18÷16	3.2	1.58	1.7	2.6	6.5	31.75
16	VS701811	ST485 16-08P CD5** #	0.15÷0.2	26÷24	3.2	1.58	0.85	1.55	6.35	31.75
16	VS701812	ST485 16-12P CD5 #	0.15÷0.75	20	3.2	1.58	1.2	2.6	6.35	31.75
16	VS701813	ST485 16-13P CD5 #	0.15÷0.6	26÷20	3.2	1.58	1.3	1.93	6.35	31.75
16	VS701859	ST485 16-14P CD5 #	0.75	18	3.2	1.58	1.35	2.2	6.4	31.75
16	VS701814	ST485 16-15P CD5 #	0.75÷1	18	3.2	1.58	1.5	2.6	6.35	31.75
16	VS701815	ST485 16-20P CD5 #	1÷2	18÷14	3.2	1.58	2	2.9	6.35	31.75
16	VS701816	ST485 16-26P CD5 #	2.5÷3	12	3.2	1.58	2.5	3.8	7	31.75
12	VS701857	ST485 12-11P CD5 #	0.5	22-20	4.8	2.38	1.1	3	8.5	37.5
12	VS701817	ST485 12-12P CD5 #	0.15÷0.75	20	4.8	2.38	1.2	2.6	8.5	37.5
12	VS701818	ST485 12-15P CD5 #	0.75÷1	18	4.8	2.38	1.5	3.4	8.5	37.5
12	VS701819	ST485 12-20P CD5 #	1÷2	18÷14	4.8	2.38	2	3.8	6.5	37.5
12	VS701820	ST485 12-22P CD5 #	2.5	-	4.8	2.38	2.2	3.8	8.5	37.5
12	VS701821	ST485 12P CD5	3	12	4.8	2.38	2.5	3.8	8.5	37.5
12	VS701822	ST485 12-30P CD5 #	4	-	4.8	2.38	3	4.8	8.5	37.5
12	VS701823	ST485 12-38P CD5 #	6	-	4.8	2.38	3.6	4.8	8	37.5
8	VS701824	ST485 8P CD5	-	8	7.8	3.6	4.55	6.8	12.2	40.7
8	VS701825	ST485 8-15P CD5** #	1	18	7.8	3.6	1.5	3.4	8.5	40.7
8	VS701826	ST485 8-18P CD5** #	1÷2	18÷14	7.8	3.6	1.8	3.8	8.5	40.7
8	VS701846	ST485 8-22P CD5 #	2.5	-	7.8	3.6	2.2	3.8	12.2	40.7
8	VS701847	ST485 8-26P CD5 #	3	12	7.8	3.6	2.5	3.8	12.2	40.7
8	VS701827	ST485 8-30P CD5 #	4	-	7.8	3.6	3	4.8	8.3	40.7
8	VS701828	ST485 8-38P CD5 #	6	10	7.8	3.6	3.6	6.8	12.2	40.6
8	VS701829	ST485 8-50P CD5 #	10	-	7.8	3.6	5	6.8	12.2	40.7
4	VS701830	ST485 4P CD5	22	4	11	5.7	7.1	9.55	12.2	41.25
4	VS701831	ST485 4-26P CD5** #	3	-	11	5.7	2.5	3.8	8.5	41.25
4	VS701832	ST485 4-30P CD5** #	4	-	11	5.7	3	4.8	8.5	41.25
4	VS701848	ST485 4-38P CD5 #	6	10	11	5.7	3.6	6.8	12.2	41.25
4	VS701833	ST485 4-50P CD5 #	10	-	11	5.7	5	6.8	12.2	41.25
4	VS701834	ST485 4-58P CD5 #	-	6	11	5.7	5.8	7.8	12.2	41.25
4	VS701835	ST485 4-62P CD5 #	16	-	11	5.7	6.2	9.5	12.2	41.25
4	VS701849	ST485 4-78P CD5 #	25	-	11	5.7	7.8	9.55	12.2	41.25
4	VS701850	ST485 4-90P CD5 #	35	2	11	5.7	9	12	14	41.25
0	VS701836	ST485 0P CD5	53	0	15.1	9.05	11.5	14.35	14.5	45
0	VS701837	ST485 0-45P CD5 #	-	8	15.1	9.05	4.55	6.8	12.2	44.5
0	VS701858	ST485 0-50P CD5 #	10	-	15.1	9.05	5	7	12.2	44.5
0	VS701851	ST485 0-58P CD5 #	-	6	15.1	9.05	5.8	7.8	14	44.5
0	VS701852	ST485 0-62P CD5 #	16	-	15.1	9.05	6.2	9.5	12.2	44.5
0	VS701838	ST485 0-78P CD5 #	25	-	15.1	9.05	7.8	9.5	14	44.5
0	VS701853	ST485 0-80P CD5 #	-	3	15.1	9.05	8	10	14	44.5
0	VS701839	ST485 0-90P CD5 #	35	2	15.1	9.05	9	14.35	13.6	44.5
0	VS701840	ST485 0-107P CD5 #	50	-	15.1	9.05	10.7	14.35	14.5	44.5
0	VS701854	ST485 0-135P CD5 #	67.4	2/0	15.1	9.05	13.5	16.5	18	51.9
4/0	VS701841	ST485 4/0-115P CD5 #	53	0	20	12.73	11.5	14.35	16.3	58.5
4/0	VS701842	ST485 4/0-135P CD5 #	67.4	2/0	20	12.73	13.5	16.5	18	58.5
4/0	VS701843	ST485 4/0-144P CD5 #	70	-	20	12.73	14.4	20	20	58.5
4/0	VS701844	ST485 4/0-155P CD5 #	95	-	20	12.73	15.2	19.7	20	58.5
4/0	VS701845	ST485 4/0P CD5	107÷120	4/0	20	12.73	15.2	19.7	20	58.5

● New Contacts

(a) For arrangement 40A201

(b) For arrangements 24A55, 28-72, 32A101 and 28A31

(c) For arrangement 22A24

** On request (please consult our Sales Office)

See notes page "Contacts - Part number explanation" for contacts with

ØD different from standard

Dimensions in mm

Crimp Contacts - ST - For Rubber insert

Socket Contacts - Gold Plated

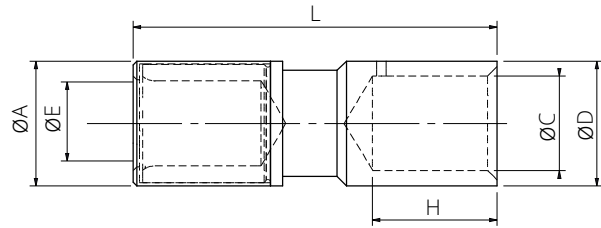
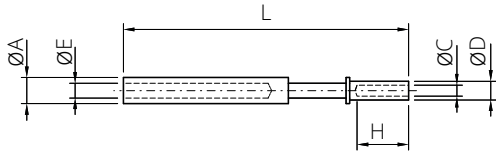

Contact Size	Part Number	Short Description	Wire section (mm ²)	AWG cable size	ØA	ØE	ØC	ØD	H	L
20	VS701700	ST485 20S CD5 (a)** / *	0.15±0.3	26÷22	2	1.15	0.9	1.6	4	32.5
-	-	-	-	-	-	-	-	-	-	-
18	VS701703	ST485 18S CD5 *	0.15±0.6	26÷20	2.4	1.46	1.3	1.93	4.5	34.4
16S	VS701704	ST485 16S CD5	1±1.5	18÷16	3.2	1.68	1.7	2.6	6.35	26.6
16S	VS701755	ST485 16S-11S CD5 #	0.25±0.5	22-20	3.2	1.68	1.1	2.15	6.5	26.6
16S	VS701705	ST485 16S-12S CD5 #	0.15±0.75	20	3.2	1.68	1.2	2.6	6.5	26.6
16S	VS701707	ST485 16S-15S CD5 #	0.75±1	18	3.2	1.68	1.5	2.6	6.5	26.6
16S	VS701756	ST485 16S-17S CD5 #	0.75	-	3.2	1.68	1.75	2.62	6.5	26.6
16S	VS701708	ST485 16S-20S CD5 #	1±2	18÷14	3.2	1.68	2	2.9	6.5	26.6
16S	VS701709	ST485 16S-26S CD5 #	2.5±3	12	3.2	1.68	2.5	3.8	7	27
16	VS701710	ST485 16S CD5	1±1.5	18÷16	3.2	1.68	1.7	2.6	6.5	36.5
16	VS701711	ST485 16-08S CD5** #	0.15±0.2	26÷24	3.2	1.68	0.85	1.55	6.35	36.5
16	VS701712	ST485 16-12S CD5 #	0.15±0.75	20	3.2	1.68	1.2	2.6	6.5	36.5
16	VS701713	ST485 16-13S CD5 #	0.15±0.6	26÷20	3.2	1.68	1.3	1.93	6.35	36.5
16	VS701759	ST485 16-14S CD5 #	0.75	18	3.2	1.68	1.35	2.2	6.4	36.5
16	VS701714	ST485 16-15S CD5 #	0.75±1	18	3.2	1.68	1.5	2.6	6.5	36.5
16	VS701715	ST485 16-20S CD5 #	1±2	18÷14	3.2	1.68	2	2.9	6.5	36.5
16	VS701716	ST485 16-26S CD5 #	2.5±3	12	3.2	1.68	2.5	3.8	7	36.5
12	VS701757	ST485 12-11S CD5 #	0.5	22-20	4.8	2.48	1.1	3	8.5	37.5
12	VS701717	ST485 12-12S CD5 #	0.15±0.75	20	4.8	2.48	1.2	2.6	8.5	37.5
12	VS701718	ST485 12-15S CD5 #	0.75±1	18	4.8	2.48	1.5	3.4	8.5	37.5
12	VS701719	ST485 12-20S CD5 #	1±2	18÷14	4.8	2.48	2	3.8	6.5	37.5
12	VS701720	ST485 12-22S CD5 #	2.5	-	4.8	2.48	2.2	3.8	8.5	37.5
12	VS701721	ST485 12S CD5	3	12	4.8	2.48	2.5	3.8	8.5	37.5
12	VS701722	ST485 12-30S CD5 #	4	-	4.8	2.48	3	4.8	8.5	37.5
12	VS701723	ST485 12-38S CD5 #	6	-	4.8	2.48	3.6	4.8	8.5	37.5
8	VS701724	ST485 8S CD5	-	8	7.8	3.7	4.55	6.8	12.2	40.7
8	VS701725	ST485 8-15S CD5** #	1	18	7.8	3.7	1.5	3.4	8.5	40.7
8	VS701726	ST485 8-18S CD5** #	1±2	18÷14	7.8	3.7	1.8	3.8	8.5	40.7
8	VS701746	ST485 8-22S CD5 #	2.5	-	7.8	3.7	2.2	3.8	12.2	40.7
8	VS701747	ST485 8-26S CD5 #	3	12	7.8	3.7	2.5	3.8	12.2	40.7
8	VS701727	ST485 8-30S CD5 #	4	-	7.8	3.7	3	4.8	8.3	40.7
8	VS701728	ST485 8-38S CD5 #	6	10	7.8	3.7	3.6	6.8	12.2	40.7
8	VS701729	ST485 8-50S CD5 #	10	-	7.8	3.7	5	7	11.5	40.7
4	VS701730	ST485 4S CD5	22	4	11	5.8	7.1	9.55	12.2	41.2
4	VS701731	ST485 4-26S CD5** #	3	-	11	5.8	2.5	3.8	8.5	41.2
4	VS701732	ST485 4-30S CD5** #	4	-	11	5.8	3	4.8	8.5	41.2
4	VS701748	ST485 4-38S CD5 #	6	10	11	5.8	3.6	6.8	12.2	41.2
4	VS701733	ST485 4-50S CD5 #	10	-	11	5.8	5	6.8	12.2	41.2
4	VS701734	ST485 4-58S CD5 #	-	6	11	5.8	5.8	7.8	12.2	41.2
4	VS701735	ST485 4-62S CD5 #	16	-	11	5.8	6.2	9.5	12.2	41.2
4	VS701749	ST485 4-78S CD5 #	25	-	11	5.8	7.8	9.5	12.2	41.2
4	VS701750	ST485 4-90S CD5 #	35	2	11	5.8	9	12	14	47
0	VS701736	ST485 0S CD5	53	0	15.1	10.3	11.5	14.35	14.5	45
0	VS701737	ST485 0-45S CD5 #	-	8	15.1	10.3	4.55	6.8	12.7	45
0	VS701758	ST485 0-50S CD5 #	10	-	15.1	10.3	5	7	12.2	45
0	VS701751	ST485 0-58S CD5 #	-	6	15.1	10.3	5.8	7.8	14	45
0	VS701752	ST485 0-62S CD5 #	16	-	15.1	10.3	6.2	9.5	12.2	45
0	VS701738	ST485 0-78S CD5 #	25	-	15.1	10.3	7.8	9.5	14	45
0	VS701753	ST485 0-80S CD5 #	-	3	15.1	10.3	8	10	14	45
0	VS701739	ST485 0-90S CD5 #	35	2	15.1	10.3	9	14.35	14	45
0	VS701740	ST485 0-107S CD5 #	50	-	15.1	10.3	10.7	14.35	14.5	45
0	VS701754	ST485 0-135S CD5 #	67.4	2/0	15.1	10.3	13.5	16.5	18	52
4/0	VS701741	ST485 4/0-115S CD5 #	53	0	20	13.65	11.5	14.35	17	59
4/0	VS701742	ST485 4/0-135S CD5 #	67.4	2/0	20	13.65	13.5	16.5	18	59
4/0	VS701743	ST485 4/0-144S CD5 #	70	-	20	13.65	14.4	20	20	59
4/0	VS701744	ST485 4/0-155S CD5 #	95	-	20	13.65	15.2	19.7	20	59
4/0	VS701745	ST485 4/0S CD5	107±120	4/0	20	13.65	15.2	19.7	20	59

● New Contacts ^(a) For all arrangements with contacts size 20 ^{**} On request (please consult our Sales Office) Dimensions in mm
 * Close entry contact type
 # See notes page "Contacts - Part number explanation" for contacts with ØD different from standard

Crimp Contacts with Louver - ST - For Rubber insert

Socket Contacts - Silver Plated

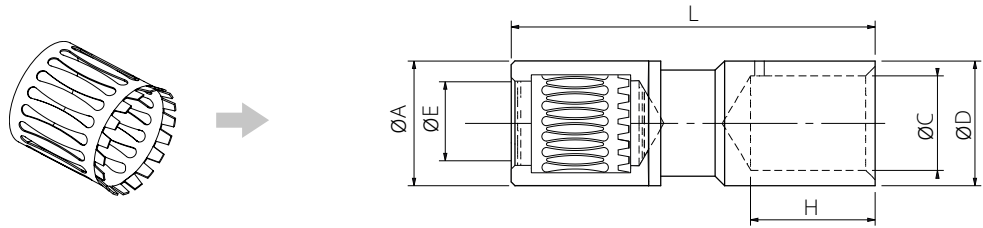

Contact Size	Part Number	Short Description	Wire section (mm ²)	AWG cable size	ØA	ØE	ØC	ØD	H	L
● 8L	VS702351	ST485 8L-17S #	1.5	16	7.8	3.6	1.7	4	8.5	38
● 8L	VS702352	ST485 8L-23S #	2.5	-	7.8	3.6	2.3	4	8.5	38
● 8L	VS702353	ST485 8L-35S #	6	10	7.8	3.6	3.5	5	8.5	38
● 8L	VS702354	ST485 8L-46S #	10	-	7.8	3.6	4.6	6.35	12.2	38
● 0L	VS702355	ST485 0L-62S #	16	-	15	9	6.2	9.3	16	50
● 0L	VS702356	ST485 0L-76S #	25	-	15	9	7.6	11.7	17	51
● 0L	VS702357	ST485 0L-89S #	35	-	15	9	8.9	13	19	53
● 0L	VS702358	ST485 0L-105S #	50	-	15	9	10.5	14.6	20.5	55

Pin Contacts - Silver Plated

(To be mated with Louver Socket Contacts and Standard ST485 Socket Contacts)

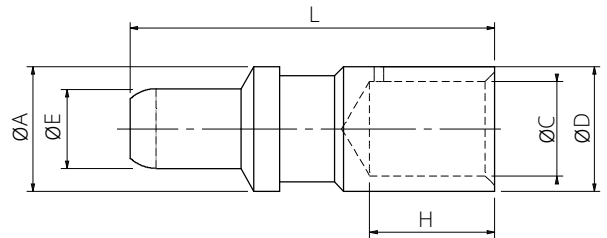

Contact Size	Part Number	Short Description	Wire section (mm ²)	AWG cable size	ØA	ØE	ØC	ØD	H	L
● 8L	VS702301	ST485 8L-17P #	1.5	16	7.8	3.6	1.7	4	8.5	41
● 8L	VS702302	ST485 8L-23P #	2.5	-	7.8	3.6	2.3	4	8.5	41
● 8L	VS702303	ST485 8L-35P #	6	10	7.8	3.6	3.5	5	8.5	41
● 8L	VS702304	ST485 8L-46P #	10	-	7.8	3.6	4.6	6.35	12.2	41
● 0L	VS702305	ST485 0L-62P #	16	-	15	9	6.2	9.3	17	51
● 0L	VS702306	ST485 0L-76P #	25	-	15	9	7.6	11.7	17	52
● 0L	VS702307	ST485 0L-89P #	35	-	15	9	8.9	13	19	53
● 0L	VS702308	ST485 0L-105P #	50	-	15	9	10.5	14.6	20.5	56

● **New Contacts**
Dimensions in mm

** On request (please consult our Sales Office)

^(*) P/N concerning silver plated contacts, add code CD5 for gold plated contacts (Part Number to be required).

Contact Size	Rated Current
8L	56A
0L	200A
4/0L	300A

See notes page "Contacts - Part number explanation" for contacts with ØD different from standard

Crimp Contacts with Touch Proof - ST - For Rubber insert

Socket Contacts - Silver Plated

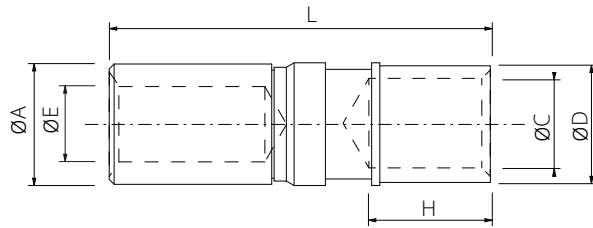
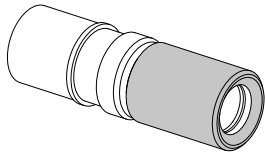

Contact Size	Part Number	Short Description(*)	Wire section (mm ²)	AWG cable size	ØA	ØE	ØC	ØD	H	L
● 0	VS702451	ST485 0S FT	53	0	15.1	13.2	11.5	6.8	14.5	45
● 0	VS702452	ST485 0-50S FT #	10	-	15.1	13.2	5	7	12.2	45
● 0	VS702453	ST485 0-90S FT #	35	2	15.1	13.2	9	14.35	14	43.4
● 0	VS702454	ST485 0-107S FT #	50	-	15.1	13.2	10.7	14.35	13.6	45

Pin Contacts - Silver Plated

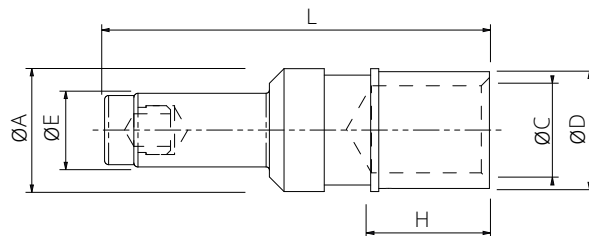
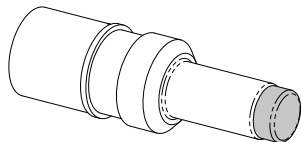

Contact Size	Part Number	Short Description(*)	Wire section (mm ²)	AWG cable size	ØA	ØE	ØC	ØD	H	L
● 0	VS702401	ST485 0P FT	53	0	15.1	9.05	11.5	14.35	14.5	45
● 0	VS702402	ST485 0-50P FT #	10	-	15.1	9.05	5	7	12.2	44.5
● 0	VS702403	ST485 0-90P FT #	35	2	15.1	9.05	9	14.35	13.6	44.5
● 0	VS702404	ST485 0-107P FT #	50	-	15.1	9.05	10.7	14.35	14.6	44.5

● **New Contacts**

Dimensions in mm

** On request (please consult our Sales Office)

(*) P/N concerning silver plated contacts, add code CD5 for gold plated contacts (Part Number to be required).

See notes page "Contacts - Part number explanation" for contacts with ØD different from standard

Crimp Contacts Close Entry - ST - For Rubber insert

Socket Contacts - Silver Plated

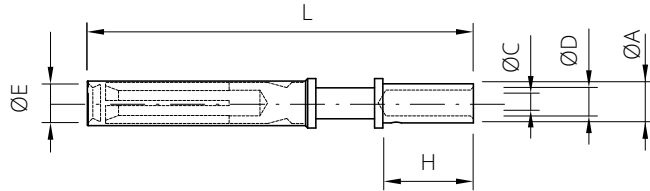
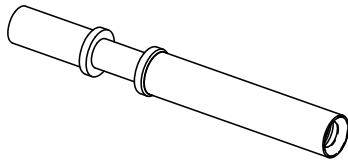

Contact Size	Part Number	Short Description	Wire section (mm ²)	AWG cable size	ØA	ØE	ØC	ØD	H	L
● 16S	VS702501	ST485 16SS CLE	1÷1.5	18÷16	3.2	1.68	1.7	2.6	6.35	27
● 16S	VS702502	ST485 16S-13S CLE #	0.15÷0.5	26÷20	3.2	1.68	1.3	1.93	6.5	26.6
● 16	VS702503	ST485 16S CLE	1÷1.5	18÷16	3.2	1.68	1.7	2.6	6.5	36.5
● 16	VS702504	ST485 16-12S CLE #	0.6	20	3.2	1.68	1.2	2.6	6.5	36.5
● 16	VS702505	ST485 16-15S CLE #	1	18	3.2	1.68	1.5	2.6	6.5	36.5
● 12	VS702506	ST485 12-12S CLE #	0.6	20	4.8	2.48	1.2	2.6	8.5	37.5
● 12	VS702507	ST485 12S CLE	3	12	3.2	2.48	2.5	3.8	8.5	37.5
● 12	VS702508	ST485 12-30S CLE #	4	-	4.8	2.48	3	4.8	8.5	37.5

Socket Contacts - Gold Plated

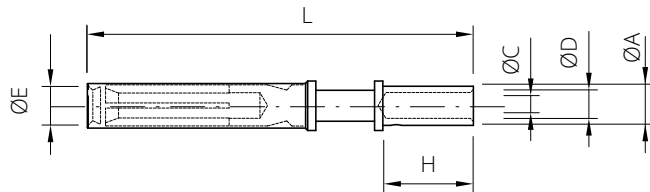
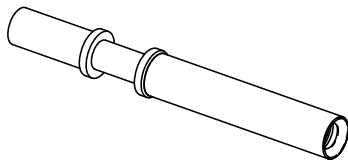

Contact Size	Part Number	Short Description	Wire section (mm ²)	AWG cable size	ØA	ØE	ØC	ØD	H	L
● 16S	VS702551	ST485 16SS CLE CD5	1÷1.5	18÷16	3.2	1.68	1.7	2.6	6.35	27
● 16S	VS702552	ST485 16S-13S CLE CD5 #	0.15÷0.5	26÷20	3.2	1.68	1.3	1.93	6.5	26.6
● 16	VS702553	ST485 16S CLE CD5	1÷1.5	18÷16	3.2	1.68	1.7	2.6	6.5	36.5
● 16	VS702554	ST485 16-12S CLE CD5 #	0.6	20	3.2	1.68	1.2	2.6	6.5	36.5
● 16	VS702555	ST485 16-15S CLE CD5 #	1	18	3.2	1.68	1.5	2.6	6.5	36.5
● 12	VS702556	ST485 12-12S CLE CD5 #	0.6	20	4.8	2.48	1.2	2.6	8.5	37.5
● 12	VS702557	ST485 12S CLE CD5	3	12	3.2	2.48	2.5	3.8	8.5	37.5
● 12	VS702558	ST485 12-30S CLE CD5 #	4	-	4.8	2.48	3	4.8	8.5	37.5

● **New Contacts**

Dimensions in mm

See notes page "Contacts - Part number explanation" for contacts with ØD different from standard

Contacts FMLB First Mate Last Break - ST - For Rubber insert

Pin Contacts - Crimp - Silver Plated

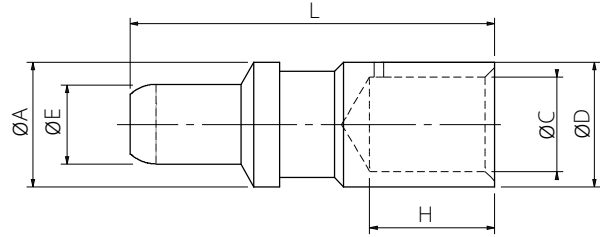
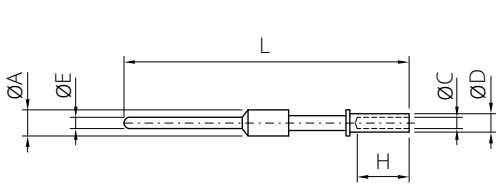

Contact Size	Part Number	Short Description	Wire section (mm ²)	AWG cable size	ØA	ØE	ØC	ØD	H	L
● 16S	VS702601	ST485 16SP FM	1÷1.5	18÷16	3.2	1.58	1.7	2.6	6.5	28.9
● 16	VS702602	ST485 16P FM	1÷1.5	18÷16	3.2	1.58	1.7	2.6	6.5	35.8
● 12	VS702603	ST485 12P FM	3	12	4.8	2.38	2.5	3.8	8.5	40
● 12	VS702604	ST485 12-38P FM #	6	-	4.8	2.38	3.6	4.8	8	40
● 8	VS702605	ST485 8P FM	-	8	7.8	3.6	4.55	6.8	12.2	40.7
● 0	VS702606	ST485 0P FM	53	0	15.1	9.05	11.5	14.35	14.5	46.2
● 0	VS702607	ST485 0-90P FM #	35	2	15.1	9.05	9	14.35	13.6	45.7

Pin Contacts - Solder - Silver Plated

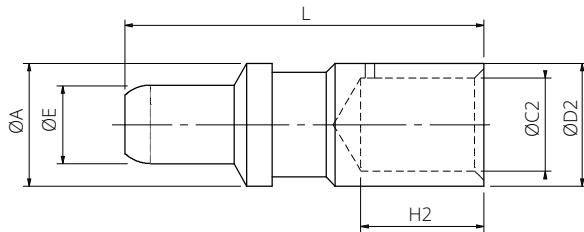
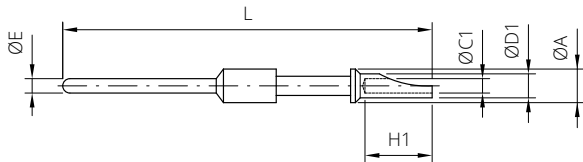

Contact size	Part Number	Short Description	AWG Cable size	ØA	ØE	ØC1	ØC2	ØD1	ØD2	H1	H2	L
● 16S	VS702041	ST385 16SP FM	18÷16	3.2	1.58	1.8	-	2.6	-	5.5	-	29.4
● 16	VS702042	ST385 16P FM	18÷16	3.2	1.58	1.8	-	2.6	-	7	-	35.9
● 12	VS702043	ST385 12P FM	12	4.8	2.38	2.9	-	3.7	-	8	-	36.5
● 8	VS702044	ST385 8P FM	9	7.8	3.6	-	5.3	-	6.6	-	12.6	38.9

● New Contacts

Dimensions in mm

See notes page "Contacts - Part number explanation" for contacts with ØD different from standard

Contacts AO Advance Opening Contacts - ST - For Rubber insert

Pin Contacts - Crimp - Silver Plated

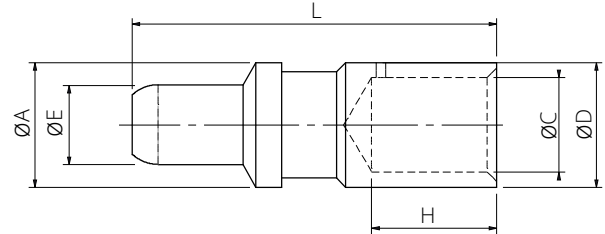
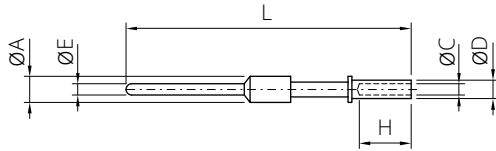

Contact Size	Part Number	Short Description	Wire section (mm ²)	AWG cable size	ØA	ØE	ØC	ØD	H	L
● 16S	**	ST485 16SP AO	1÷1.5	18÷16	3.2	1.58	1.7	2.6	6.5	28.9
● 16	**	ST485 16P AO	1÷1.5	18÷16	3.2	1.58	1.7	2.6	6.5	35.8
● 12	**	ST485 12P AO	3	12	4.8	2.38	2.5	3.8	8.5	32
● 12	**	ST485 12-38P AO #	6	-	4.8	2.38	3.6	4.8	8	32
● 8	**	ST485 8P AO	-	8	7.8	3.6	4.55	6.8	12.2	40.7
● 0	**	ST485 0P AO	53	0	15.1	9.05	11.5	14.35	14.5	46.2
● 0	**	ST485 0-90P AO #	35	2	15.1	9.05	9	14.35	13.6	45.7

Pin Contacts - Solder - Silver Plated

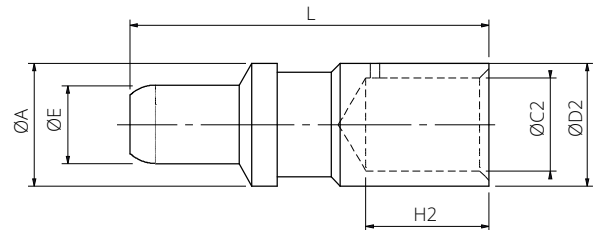
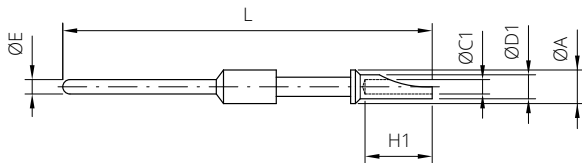

Contact size	Part Number	Short Description	AWG Cable size	ØA	ØE	ØC1	ØC2	ØD1	ØD2	H1	H2	L
● 16S	**	ST385 16SP AO	18÷16	3.2	1.58	1.8	-	2.6	-	5.5	-	29.4
● 16	**	ST385 16P AO	18÷16	3.2	1.58	1.8	-	2.6	-	7	-	35.9
● 12	**	ST385 12P AO	12	4.8	2.38	2.9	-	3.7	-	8	-	28.5
● 8	**	ST385 8P AO	9	7.8	3.6	-	5.3	-	6.6	-	12.6	38.9

● New Contacts

Dimensions in mm

** On request (please consult our Sales Office)

See notes page "Contacts - Part number explanation" for contacts with ØD different from standard

ST Contacts - for Lug

Pin Contacts - Silver Plated

- Cannot be used with grommet
- It is mandatory the use of heat shrink tube

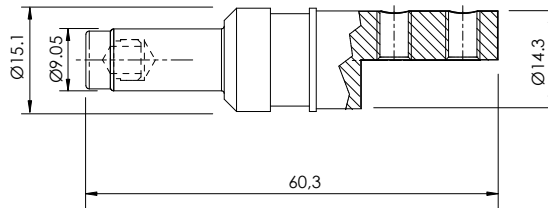
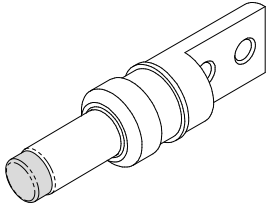

Contact Size	Part Number	Short Description(*)
0	on request	ST585 0P

Socket Contacts - Silver Plated

- Cannot be used with grommet
- It is mandatory the use of heat shrink tube

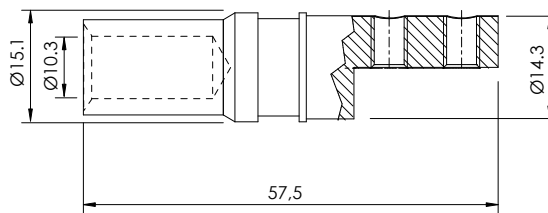
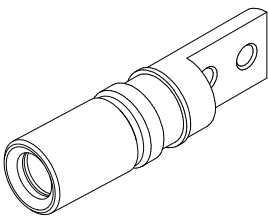

Contact Size	Part Number	Short Description(*)
0	on request	ST585 0S

Dimensions in mm

KT Contacts - for thermoplastics inserts

Pin Contacts - Crimp - Gold Plated

Must be used with KVBS inserts or GVJ inserts (48A4 and 48A7)

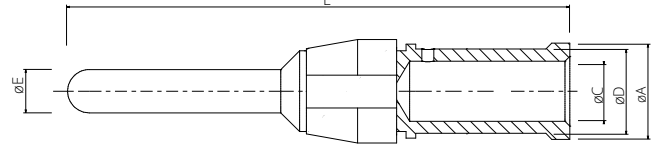
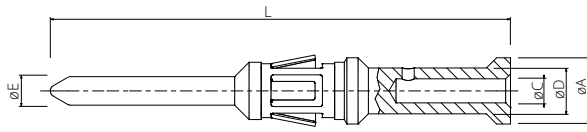

Contact Size	Part Number	Short Description(*)	Wire section (mm ²)	AWG cable size	ØA	ØE	ØC	ØD	L
16	VS701301	KT485 16-13P CD5**	0.15÷0.6	26÷20	3.7	1.57	1.3	1.93	33.4
16	VS701302	KT485 16-12P CD5	0.5÷0.75	-	3.7	1.57	1.2	2.6	33.4
16	VS701303	KT485 16-20P CD5	1÷2	18÷14	3.7	1.57	2	2.9	33.4
16	VS701304	KT485 16-26P CD5	2.5÷3	-	3.7	1.57	2.5	3.8	33.4
12	VS701305	KT485 12-12P CD5	0.6	20	5.5	2.37	1.2	2.6	38.2
12	VS701306	KT485 12-20P CD5	1÷2	18÷14	5.5	2.37	2	3.8	38.2
12	VS701307	KT485 12-26P CD5	2.5÷3	-	5.5	2.37	2.5	3.8	38.2
12	VS701308	KT485 12-30P CD5	4	-	5.5	2.37	3	4.8	38.2
12	VS701309	KT485 12-38P CD5	6	-	5.5	2.37	3.6	4.8	38.2
8	VS701310	KT485 8-15P CD5	1	-	8	3.59	1.5	3.4	41.7
8	VS701311	KT485 8-22P CD5	2.5	-	8	3.59	2.2	3.8	41.7
8	VS701312	KT485 8-30P CD5**	4	-	8	3.59	3	4.8	41.7
8	VS701313	KT485 8-38P CD5	6	-	8	3.59	3.6	4.8	41.7
8	VS701314	KT485 8-50P CD5**	10	-	8	3.59	5	7	41.7

Socket Contacts - Crimp - Gold Plated

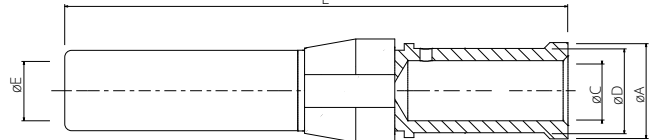
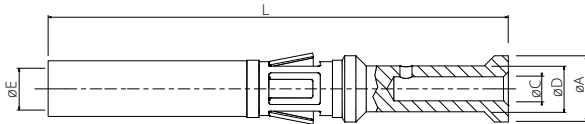

Contact Size	Part Number	Short Description(*)	Wire section (mm ²)	AWG cable size	ØA	ØE	ØC	ØD	L
16	VS701401	KT485 16-13S CD5**	0.15÷0.6	26÷20	3.7	1.65	1.3	1.93	38.4
16	VS701402	KT485 16-12S CD5	0.5÷0.75	-	3.7	1.65	1.2	2.6	38.4
16	VS701403	KT485 16-20S CD5	1÷2	18÷14	3.7	1.65	2	2.9	38.4
16	VS701404	KT485 16-26S CD5	2.5÷3	-	3.7	1.65	2.5	3.8	38.4
12	VS701405	KT485 12-12S CD5	0.6	20	5.5	2.48	1.2	2.6	38.7
12	VS701406	KT485 12-20S CD5	1÷2	18÷14	5.5	2.48	2	3.8	38.7
12	VS701407	KT485 12-26S CD5	2.5÷3	-	5.5	2.48	2.5	3.8	38.7
12	VS701408	KT485 12-30S CD5	4	-	5.5	2.48	3	4.8	38.7
12	VS701409	KT485 12-38S CD5	6	-	5.5	2.48	3.6	4.8	38.7
8	VS701410	KT485 8-15S CD5	1	-	8	3.7	1.5	3.4	41.7
8	VS701411	KT485 8-22S CD5	2.5	-	8	3.7	2.2	3.8	41.7
8	VS701412	KT485 8-30S CD5**	4	-	8	3.7	3	4.8	41.7
8	VS701413	KT485 8-38S CD5	6	-	8	3.7	3.6	4.8	41.7
8	VS701414	KT485 8-50S CD5**	10	-	8	3.7	5	7	41.7

Dimensions in mm

** On request (please consult our Sales Office)

KT Contacts with Louver - for thermoplastics inserts

Socket Contacts - Crimp - Silver Plated

Must be used with KVBS inserts or GVJ inserts (48A4 and 48A7)

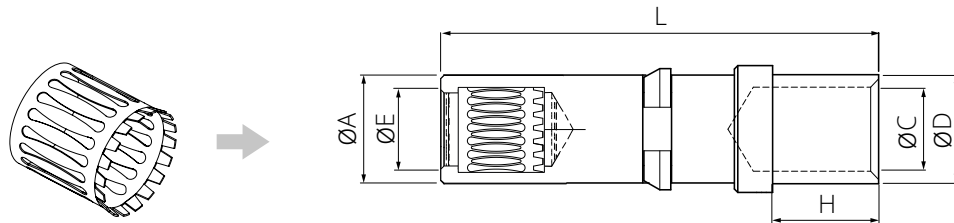

Contact Size	Part Number	Short Description *	Wire section (mm ²)	AWG cable size	ØA	ØE	ØC	ØD	H	L
4/0L	VS701251	KT485 4/0L-115S	53	0	19.8	20	11.5	14.35	16.3	81
4/0L	VS701252	KT485 4/0L-144S	70	-	19.8	20	14.4	20	23	81
4/0L	VS701253	KT485 4/0L-155S	95	-	19.8	20	15.5	20	23	81
4/0L	VS701254	KT485 4/0L-S	107÷120	4/0	19.8	20	16.5	7	4.5	81

Pin Contacts - Crimp - Silver Plated

(For Louver Socket contacts)

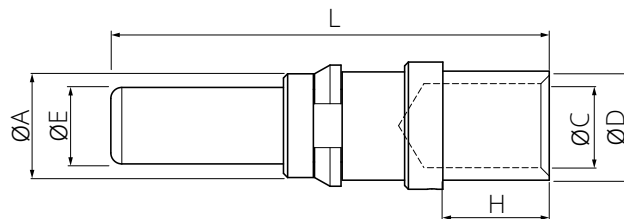

Contact Size	Part Number	Short Description *	Wire section (mm ²)	AWG cable size	ØA	ØE	ØC	ØD	H	L
4/0L	VS701151	KT485 4/0L-115P	53	0	20	14	11.5	14.35	16.3	82.4
4/0L	VS701152	KT485 4/0L-144P	70	-	20	14	14.4	20	23	82.4
4/0L	VS701153	KT485 4/0L-155P	95	-	20	14	15.5	20	23	82.4
4/0L	VS701154	KT485 4/0L-P	107÷120	4/0	20	14	16.5	20	23	82.4

● **New Contacts**
Dimensions in mm

* P/N concerning silver plated contacts, add code CD5 for gold plated contacts (Part Number to be required).

Contact Size	Rated Current
4/0L	300A

Crimp Adapters

For Contacts ST Type

To be used in case of wire section smaller than contact termination. They are available with silver or gold finish. Alternative versions can be designed and supplied on request for different wire sections.

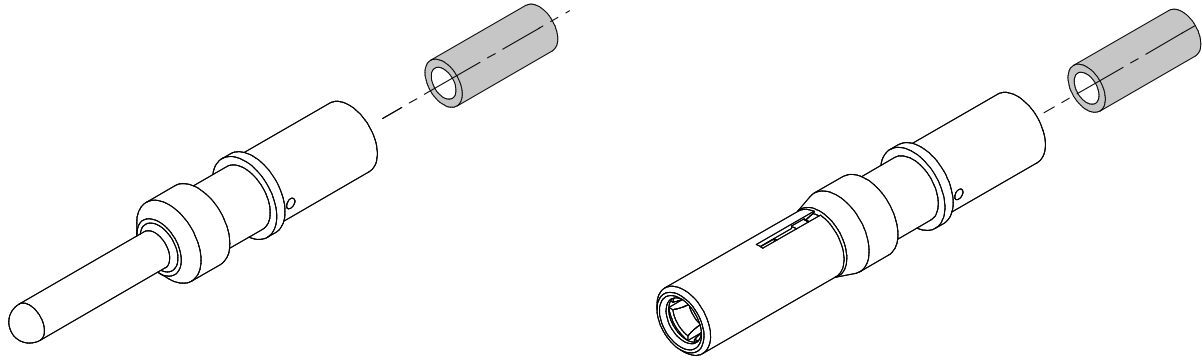

Silver Plated

Contact size	Part Number	Adapter P/N	Wire section (mm ²)	AWG cable size	Can be used with contact
12	-	AP485 12-17	-	16	**
8	-	AP485 8-26	3	12	**
8	-	AP485 8-17	1.5	-	**
8	-	AP485 8-22	2.5	-	**
8	-	AP485 8-30	4	-	ST485 8P / ST485 8S
8	VS412201	AP485 8-38	6	10	ST485 8P / ST485 8S
4	-	AP485 4-45	-	8	**
4	VS412202	AP485 4-17	1.5	-	ST485 4P / ST485 4S
4	VS412203	AP485 4-30	4	-	ST485 4P / ST485 4S
4	VS412204	AP485 4-38	6	10	ST485 4P / ST485 4S
4	VS412205	AP485 4-50	10	-	ST485 4P / ST485 4S
4	VS412206	AP485 4-62	16	-	ST485 4P / ST485 4S
0	-	AP485 0-72	-	4	**
0	VS412207	AP485 0-78	25	-	ST485 0P / ST485 0S

Gold Plated

Contact size	Part Number	Adapter P/N	Wire section (mm ²)	AWG cable size	Can be used with contact
12	-	AP485 12-17 CD5	-	16	**
8	-	AP485 8-26 CD5	3	12	**
8	-	AP485 8-17 CD5	1.5	-	**
8	-	AP485 8-22 CD5	2.5	-	**
8	VS412251	AP485 8-30 CD5	4	-	ST485 8P / ST485 8S
8	VS412252	AP485 8-38 CD5	6	10	ST485 8P / ST485 8S
4	-	AP485 4-45 CD5	-	8	**
4	VS412253	AP485 4-17 CD5	1.5	-	ST485 4P / ST485 4S
4	VS412254	AP485 4-30 CD5	4	-	ST485 4P / ST485 4S
4	VS412255	AP485 4-38 CD5	6	10	ST485 4P / ST485 4S
4	VS412256	AP485 4-50 CD5	10	-	ST485 4P / ST485 4S
4	VS412257	AP485 4-62 CD5	16	-	ST485 4P / ST485 4S
0	-	AP485 0-72 CD5	-	4	**
0	VS412258	AP485 0-78 CD5	25	-	ST485 0P / ST485 0S

** On request (please consult our Sales Office)

Coaxial Contacts - For Rubber insert

Crimp Contacts - Gold Plated

They are made to be used for size 12, 8 and 4 contact cavities according to wire and application.
For the optimum choice it is better to consult our Sales Office.

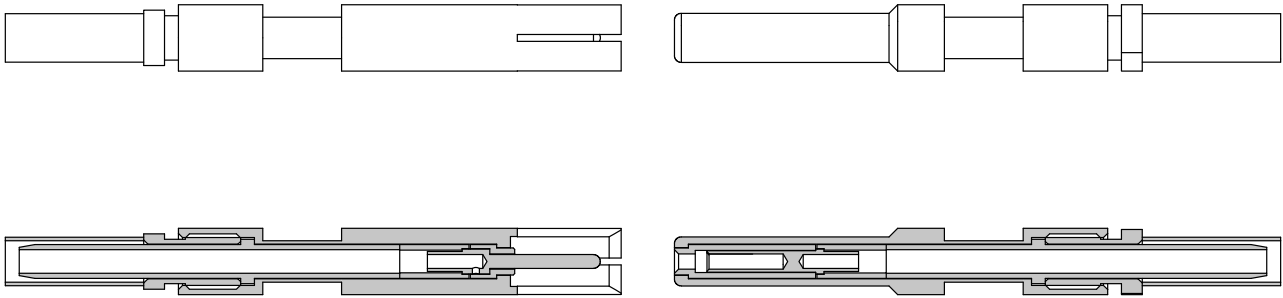

Socket Contacts

Contact cavity size	Part Number	Short Description	Used with cable
4	VS702751	CC485-4-006S	RG 6 (75 Ω)
8	VS702752	CC485-8-058S	RG 58 (50 Ω)
4	VS702753	CC485-4-059S	RG 59 (75 Ω)
8	VS702754	CC485-8-059S	RG 59 (75 Ω)
8	-	CC485-8-141S**	RG 141 (50 Ω)
8	-	CC485-8-142S**	RG 142 (50 Ω)
8	VS702755	CC485-8-174S	RG 174 (50 Ω)
12	-	CC485-12-178S**	RG 178 (50 Ω)
8	-	CC485-8-179S**	RG 179 (75 Ω)
8	VS702756	CC485-8-187S	RG 187 (75 Ω)
12	-	CC485-12-188S**	RG 188 (50 Ω)
8	-	CC485-8-400S**	RG 400 (50 Ω)

Pin Contacts

Contact cavity size	Part Number	Short Description	Used with cable
4	VS702701	CC485-4-006P	RG 6 (75 Ω)
8	VS702702	CC485-8-058P	RG 58 (50 Ω)
4	VS702703	CC485-4-059P	RG 59 (75 Ω)
8	VS702704	CC485-8-059P	RG 59 (75 Ω)
8	-	CC485-8-141P**	RG 141 (50 Ω)
8	-	CC485-8-142P**	RG 142 (50 Ω)
8	VS702705	CC485-8-174P	RG 174 (50 Ω)
12	-	CC485-12-178P**	RG 178 (50 Ω)
8	-	CC485-8-179P**	RG 179 (75 Ω)
8	VS702706	CC485-8-187P	RG 187 (75 Ω)
12	-	CC485-12-188P**	RG 188 (50 Ω)
8	-	CC485-8-400P**	RG 400 (50 Ω)

** On request (please consult our Sales Office)

Thermocouple Contacts

For CVS-CVB-CVBS-CVBSG-CVBR-GVJ Inserts

These contacts are manufactured from composite alloys.

Installed in the connectors in place of the traditional ones, they are able to avoid the signal distortion of the thermocouple connected through the connector itself.

Material is according to DIN 43710 e 43760 specs. For a clearer identification of the material, these contacts are marked with a colour coded sign and a series of lines engraved on the central part of the contact.



Size and Insert Arrangement

These contacts are supplied with special arrangement P/N. The most used are in the following table:

Thermocouple arrangement	Standard arrangement	Contacts position	Material
10SL-53	10SL-4	A	Alumel
		B	Chromel
10SL-55	10SL-3	A	Alumel
		B	Chromel
		C	Copper (standard)
14S-21	14S-2	A-C	Chromel
		B-D	Alumel
14S-22	14S-2	A	Chromel
		C	Alumel
14S-23	14S-2	B-D	Hole plug
		A-D	Chromel
14S-24	14S-2	B-C	Alumel
		A	Chromel
14S-51	14S-9	B	Alumel
		A	Chromel
14S-53	14S-9	A	Iron
		B	Costantan
14S-55	14S-2	A-C	Iron
		B-D	Costantan
14S-57	14S-2	A-C	Alumel
		B-D	Chromel
14S-58	14S-7	A	Alumel
		B	Chromel
		C	Copper (standard)
14S-71	14S-7	A	Iron
		B	Costantan
		C	Copper (standard)
14S-73	14S-5	C	Iron
		D	Costantan
14S-75	14S-7	A-B-E	Copper (standard)
		A	Copper (standard)
		B	Costantan
16S-56	16S-5	C	Copper (standard)
		A	Chromel
		B	Alumel
		C	Copper (standard)

For special compositions please consult our sales office

Thermocouple Contacts

For CVS-CVB-CVBS-CVBSG-CVBR-GVJ Inserts

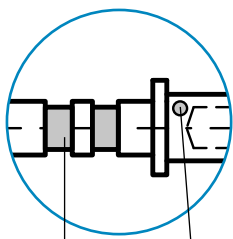

Engraved lines Identification colour

Thermocouple arrangement	Standard arrangement	Contacts position	Material
16S-57	16S-8	A-C	Copper (standard)
		B-D	Costantan
		E	Copper (standard)
18-41	18-4	A-C	Iron
		B-D	Costantan
18-42	18-4	A-C	Alumel
		B-D	Chromel
18-43	18-4	A-C	Chromel
		B-D	Costantan
18-47	18-19	A-D-J	Iron
		B-H-G	Costantan
		C-E-F-K	Copper (standard)
18-48	18-4	A	Iron
		C	Costantan
		B-D	Copper (standard)
18-49	18-4	A-C	Chromel
		B-D	Alumel
18-50	18-4	A	Chromel
		D	Alumel
		B-C	Hole plug
18-57	18-12	A-C-E	Alumel
		B-D-F	Chromel
18-72	18-1	A-C-E-G-I	Chromel
		B-D-F-H-J	Alumel
20-641	20-27	A-B-C-D-E-F-G	Alumel
		H-I-J-K-L-M-N	Chromel
24-65	24-5	A-B-C-F-H-J-K-M	Chromel
		D-E-G-L-N-P-R-S	Alumel
24-91	24A25	A-C-E-G-J-I-N-Q-S-U-W-Y	Iron
		B-D-F-H-K-M-P-R-T-V-X-Z	Costantan
28-91	28-18	25	Hole plug
		A-C-E-G-J-L	Iron
		B-D-F-H-K-M	Costantan
32-56	32-31	Even	Iron
		Odd	Costantan
		31	Hole plug
36-91	36-10	A-C-E-G-J-L-N-P-R-T-V-X-Z- b-d-f-h-k-n-q-s-u-w-y	Iron
		B-D-F-H-K-M-O-Q-S-U-W-Y-a-c-e-c-j-m-p-r-t-v-x-z	Costantan

For special compositions please consult our sales office

Thermocouple Contacts - Solder

TC Contacts

Thermocouple type	Material	Pol.	Identification colour	Engraved lines No.
T	Copper (standard)*	+	-	n.a.
	Costantan	-	Yellow	1
J	Iron	+	Black	3
	Costantan	-	Yellow	1
E	Chromel	+	White	2
	Costantan	-	Yellow	1
K	Chromel	+	White	2
	Alumel	-	Green	-

* ST385 Version

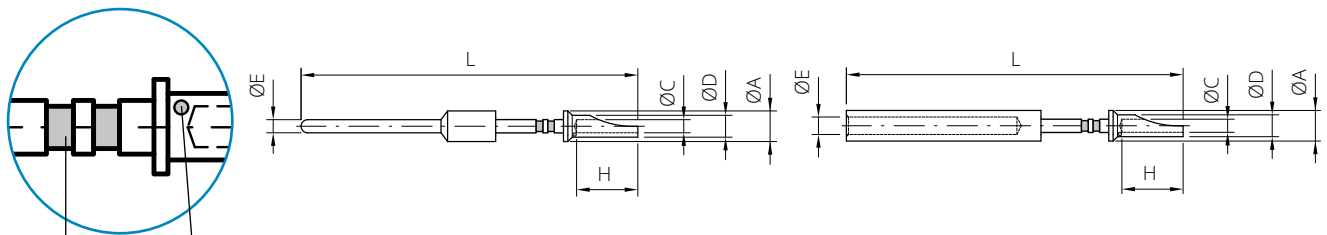

Engraved lines Identification colour

Socket Contacts

Contact size	Material	Part Number	Short ** Description	AWG Cable size	ØC	ØD	H
16S	Chromel	VS702051	TC1-385-16SS	16	1.8	3.2	5.5
16S	Alumel	VS702052	TC2-385-16SS	16	1.8	3.2	5.5
16S	Iron	VS702053	TC3-385-16SS	16	1.8	3.2	5.5
16S	Costantan	VS702054	TC4-385-16SS	16	1.8	3.2	5.5
16S	Copper (standard)	VS702011	ST385 16SS	16	1.8	3.2	5.5
16	Chromel	VS702055	TC1-385-16S	16	1.8	3.2	5.5
16	Alumel	VS702056	TC2-385-16S	16	1.8	3.2	5.5
16	Iron	VS702057	TC3-385-16S	16	1.8	3.2	5.5
16	Costantan	VS702058	TC4-385-16S	16	1.8	3.2	5.5
16	Copper (standard)	VS702012	ST385 16S	16	1.8	3.2	5.5

Pin Contacts

Contact size	Material	Part Number	Short ** Description	AWG Cable size	ØC	ØD	H
16S	Chromel	VS702081	TC1-385-16SP	16	1.8	3.2	5.5
16S	Alumel	VS702082	TC2-385-16SP	16	1.8	3.2	5.5
16S	Iron	VS702083	TC3-385-16SP	16	1.8	3.2	5.5
16S	Costantan	VS702084	TC4-385-16SP	16	1.8	3.2	5.5
16S	Copper (standard)	VS702001	ST385 16SP	16	1.8	3.2	5.5
16	Chromel	VS702085	TC1-385-16P	16	1.8	3.2	5.5
16	Alumel	VS702086	TC2-385-16P	16	1.8	3.2	5.5
16	Iron	VS702087	TC3-385-16P	16	1.8	3.2	5.5
16	Costantan	VS702088	TC4-385-16P	16	1.8	3.2	5.5
16	Copper (standard)	VS702002	ST385 16P	16	1.8	3.2	5.5

** On request (please consult our Sales Office)

Dimensions in mm

Thermocouple Contacts - Crimp

TC Contacts

Thermocouple type	Material	Pol.	Identification colour	Engraved lines No.
T	Copper (standard)*	+	-	n.a.
	Costantan	-	Yellow	1
J	Iron	+	Black	3
	Costantan	-	Yellow	1
E	Chromel	+	White	2
	Costantan	-	Yellow	1
K	Chromel	+	White	2
	Alumel	-	Green	-

* ST485 Version

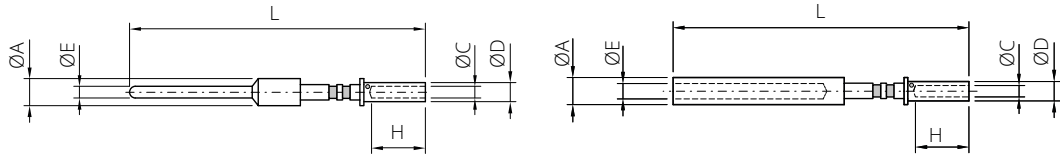
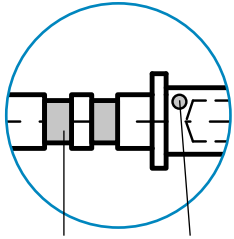

Engraved lines Identification colour

Socket Contacts

Contact Size	Material	Part Number	Short ** Description	Wire section (mm ²)	AWG cable size	ØC	ØD	H
16S	Chromel	VS702851	TC1-485-16SS	1÷1.5	16	1.7	2.6	6.35
16S	Alumel	VS702852	TC2-485-16SS	1÷1.5	16	1.7	2.6	6.35
16S	Iron	VS702853	TC3-485-16SS	1÷1.5	16	1.7	2.6	6.35
16S	Costantan	VS702854	TC4-485-16SS	1÷1.5	16	1.7	2.6	6.35
16	Chromel	VS702855	TC1-485-16-07S	0.15÷0.5	26÷20	0.75	1.6	5.3
16	Alumel	VS702856	TC2-485-16-07S	0.15÷0.5	26÷20	0.75	1.6	5.3
16	Iron	VS702857	TC3-485-16-07S	0.15÷0.5	26÷20	0.75	1.6	5.3
16	Costantan	VS702858	TC4-485-16-07S	0.15÷0.5	26÷20	0.75	1.6	5.3
16	Chromel	VS702858	TC1-485-16-15S	1	18	1.5	2.6	6.35
16	Alumel	VS702860	TC2-485-16-15S	1	18	1.5	2.6	6.35
16	Iron	VS702861	TC3-485-16-15S	1	18	1.5	2.6	6.35
16	Costantan	VS702862	TC4-485-16-15S	1	18	1.5	2.6	6.35
16	Chromel	VS702863	TC1-485-16S	1÷1.5	16	1.7	2.6	6.35
16	Alumel	VS702864	TC2-485-16S	1÷1.5	16	1.7	2.6	6.35
16	Iron	VS702865	TC3-485-16S	1÷1.5	16	1.7	2.6	6.35
16	Costantan	VS702866	TC4-485-16S	1÷1.5	16	1.7	2.6	6.35

Pin Contacts

Contact Size	Material	Part Number	Short ** Description	Wire section (mm ²)	AWG cable size	ØC	ØD	H
16S	Chromel	VS702801	TC1-485-16SP	1÷1.5	16	1.7	2.6	6.35
16S	Alumel	VS702802	TC2-485-16SP	1÷1.5	16	1.7	2.6	6.35
16S	Iron	VS702803	TC3-485-16SP	1÷1.5	16	1.7	2.6	6.35
16S	Costantan	VS702804	TC4-485-16SP	1÷1.5	16	1.7	2.6	6.35
16	Chromel	VS702805	TC1-485-16-07P	0.15÷0.5	26÷20	0.75	1.6	5.3
16	Alumel	VS702806	TC2-485-16-07P	0.15÷0.5	26÷20	0.75	1.6	5.3
16	Iron	VS702807	TC3-485-16-07P	0.15÷0.5	26÷20	0.75	1.6	5.3
16	Costantan	VS702808	TC4-485-16-07P	0.15÷0.5	26÷20	0.75	1.6	5.3
16	Chromel	VS702808	TC1-485-16-15P	1	18	1.5	2.6	6.35
16	Alumel	VS702810	TC2-485-16-15P	1	18	1.5	2.6	6.35
16	Iron	VS702811	TC3-485-16-15P	1	18	1.5	2.6	6.35
16	Costantan	VS702812	TC4-485-16-15P	1	18	1.5	2.6	6.35
16	Chromel	VS702813	TC1-485-16P	1÷1.5	16	1.7	2.6	6.35
16	Alumel	VS702814	TC2-485-16P	1÷1.5	16	1.7	2.6	6.35
16	Iron	VS702815	TC3-485-16P	1÷1.5	16	1.7	2.6	6.35
16	Costantan	VS702816	TC4-485-16P	1÷1.5	16	1.7	2.6	6.35

** On request (please consult our Sales Office)

Dimensions in mm

PCB Tail - Contacts

CVS-CVB-CVBS-CVBSG-CVBR-GVJ - Contacts

Pin and Socket contacts size 16, 16S and 12 are available with termination for wave soldering on printed circuit boards. These contacts can be used with front mounting panel connectors (CVS - CVB - CVBS - CVBSG - CVBR - GVJ 02). The following table shows available contacts dimensions.
Contact Plating: Gold plating

Consult our Sales Office for distance between contacts drawing.

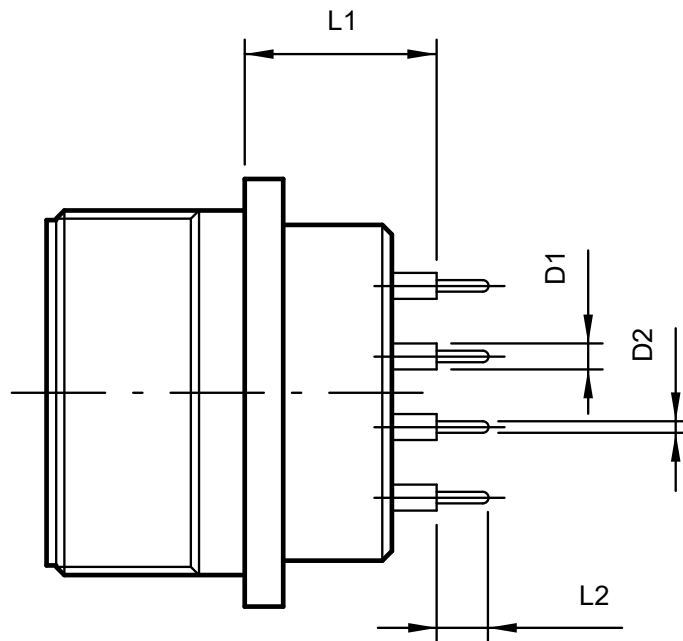

Contact Size	L1 (#)	L2 ±0.1	D1 ±0.1	D2 ±0.1
16S	-	3.1	1.8	0.8
16	-	3.6	1.8	0.8
12	-	3.6	3.4	1.8

Dimensions in mm

(#) This dimension can change with contact or shell size, insert arrangement and contacts version. We suggest to consult our Sales Office for further details.

Accessories For Connectors

CVS-CVB-CVBS-CVBSG-CVBR-GVJ



Caps for Connectors:

CV..043

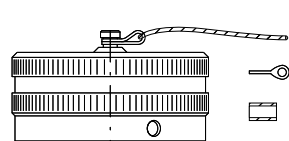
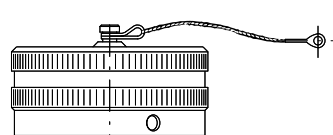
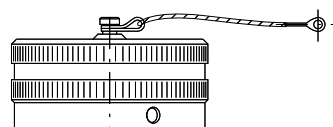
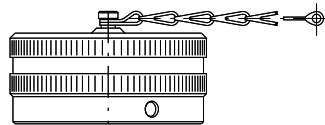

CV..042

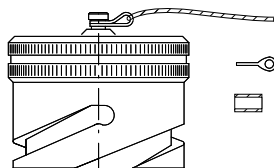
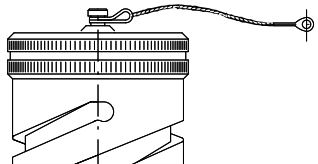
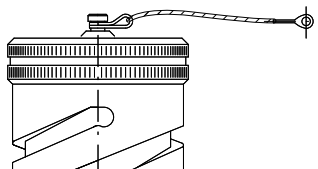
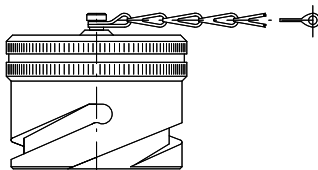

Standard Caps: Chain and lugs in stainless steel

S Caps: Stainless steel wire rope, polyamide black covered

W Caps: with textile black rope (white on request)

TL Caps: Stainless steel wire rope, polyamide black covered. Supplied with loose terminal link and crimp sleeve

Caps for Bayonet Connectors

CVB-CVBS-CVBSG-CVBR-GVJ - Accessories For Connectors

Caps with chain for connectors version: shell type with ramp

Provided with sealing gasket.

Chain and lugs are in stainless steel.

Protection degree: IP 67 (mated to the connector) according to EN 60529.

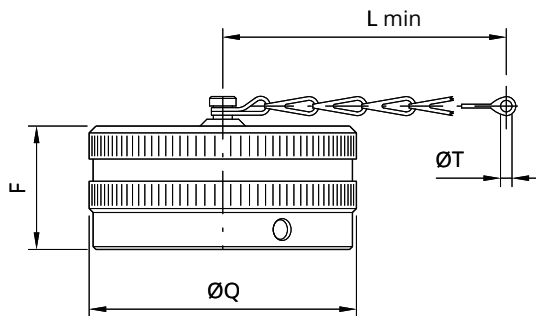

Shell size	ØQ	F	L min	ØT
10SL	23.6	16	108	4.3
14S	30	16	108	4.3
16S	33	16	108	4.3
16	33.6	20.9	123	4.3
18	38	21.7	123	4.3
20	40.5	21.7	123	4.3
22	44	21.7	123	4.3
24	47	21.7	123	4.3
28	53	21.7	206	4.3
32	60	21.7	206	4.3
36	66.2	21.7	206	4.3
40	72.4	21.7	206	4.3
GVJ	96	28.2	285	8.4

Finishes : F7 Black epoxy varnish (RoHS compliance)

Shell size	Part Number	Short Description
10SL	VS151101	CVB 043-10SL F7
14S	VS151102	CVB 043-14S F7
16S	VS151103	CVB 043-16S F7
16	VS151104	CVB 043-16 F7
18	VS151105	CVB 043-18 F7
20	VS151106	CVB 043-20 F7
22	VS151107	CVB 043-22 F7
24	VS151108	CVB 043-24 F7
28	VS151109	CVB 043-28 F7
32	VS151110	CVB 043-32 F7
36	VS151111	CVB 043-36 F7
40	VS151112	CVB 043-40 F7
GVJ	On Request	GVJ 043 F7

Finishes : F4 CCF - Green passivation - conductive

Shell size	Part Number	Short Description
10SL	VS151113	CVB 043-10SL F4
14S	VS151114	CVB 043-14S F4
16S	VS151115	CVB 043-16S F4
16	VS151116	CVB 043-16 F4
18	VS151117	CVB 043-18 F4
20	VS151118	CVB 043-20 F4
22	VS151119	CVB 043-22 F4
24	VS151120	CVB 043-24 F4
28	VS151121	CVB 043-28 F4
32	VS151122	CVB 043-32 F4
36	VS151123	CVB 043-36 F4
40	VS151124	CVB 043-40 F4

Finishes : F16 CCF - Black passivation (RoHS compliance) - conductive

Shell size	Part Number	Short Description
10SL	VS151125	CVB 043-10SL F16
14S	VS151126	CVB 043-14S F16
16S	VS151127	CVB 043-16S F16
16	VS151128	CVB 043-16 F16
18	VS151129	CVB 043-18 F16
20	VS151130	CVB 043-20 F16
22	VS151131	CVB 043-22 F16
24	VS151132	CVB 043-24 F16
28	VS151133	CVB 043-28 F16
32	VS151134	CVB 043-32 F16
36	VS151135	CVB 043-36 F16
40	VS151136	CVB 043-40 F16
GVJ	On Request	GVJ 043 F16

Finishes : F5 Electroless nickel (RoHS compliance)

Shell size	Part Number	Short Description
10SL	VS151137	CVB 043-10SL F5
14S	VS151138	CVB 043-14S F5
16S	VS151139	CVB 043-16S F5
16	VS151140	CVB 043-16 F5
18	VS151141	CVB 043-18 F5
20	VS151142	CVB 043-20 F5
22	VS151143	CVB 043-22 F5
24	VS151144	CVB 043-24 F5
28	VS151145	CVB 043-28 F5
32	VS151146	CVB 043-32 F5
36	VS151147	CVB 043-36 F5
40	VS151148	CVB 043-40 F5

Dimensions in mm

Caps for Bayonet Connectors

CVB-CVBS-CVBSG-CVBR-GVJ - Accessories For Connectors

Caps with chain for connector version: shell type with coupling nut

These caps have no sealing gasket because mated with connectors generally provided with front gasket.

Chain and lugs are in stainless steel.

Protection degree: IP 67 (mated to the connector) according to EN 60529.

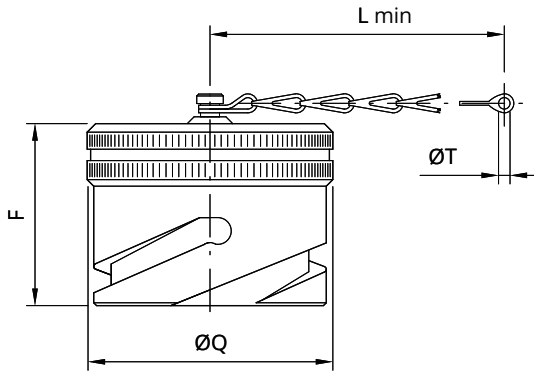

Shell size	ØQ	F	L min	ØT
10SL	20.6	27.3	108	4.3
14S	27	27.3	123	4.3
16S	29.8	27.3	123	4.3
16	29.8	34.5	123	4.3
18	33	34.5	123	4.3
20	36.5	34.5	138	4.3
22	39.7	34.5	138	4.3
24	43.2	34.5	138	4.3
28	48.9	34.5	206	4.3
32	55.5	34.5	206	4.3
36	61.6	34.5	206	4.3
40	67.6	34.5	206	4.3
GVJ	93	60	285	8.4

Finishes : F7 Black epoxy varnish (RoHS compliance)

Shell size	Part Number	Short Description
10SL	VS151201	CVB 042-10SL F7
14S	VS151202	CVB 042-14S F7
16S	VS151203	CVB 042-16S F7
16	VS151204	CVB 042-16 F7
18	VS151205	CVB 042-18 F7
20	VS151206	CVB 042-20 F7
22	VS151207	CVB 042-22 F7
24	VS151208	CVB 042-24 F7
28	VS151209	CVB 042-28 F7
32	VS151210	CVB 042-32 F7
36	VS151211	CVB 042-36 F7
40	VS151212	CVB 042-40 F7
GVJ	On Request	GVJ 04 F7

Finishes : F4 CCF - Green passivation - conductive

Shell size	Part Number	Short Description
10SL	VS151213	CVB 042-10SL F4
14S	VS151214	CVB 042-14S F4
16S	VS151215	CVB 042-16S F4
16	VS151216	CVB 042-16 F4
18	VS151217	CVB 042-18 F4
20	VS151218	CVB 042-20 F4
22	VS151219	CVB 042-22 F4
24	VS151220	CVB 042-24 F4
28	VS151221	CVB 042-28 F4
32	VS151222	CVB 042-32 F4
36	VS151223	CVB 042-36 F4
40	VS151224	CVB 042-40 F4

Finishes : F16 CCF - Black passivation (RoHS compliance) - conductive

Shell size	Part Number	Short Description
10SL	VS151225	CVB 042-10SL F16
14S	VS151226	CVB 042-14S F16
16S	VS151227	CVB 042-16S F16
16	VS151228	CVB 042-16 F16
18	VS151229	CVB 042-18 F16
20	VS151230	CVB 042-20 F16
22	VS151231	CVB 042-22 F16
24	VS151232	CVB 042-24 F16
28	VS151233	CVB 042-28 F16
32	VS151234	CVB 042-32 F16
36	VS151235	CVB 042-36 F16
40	VS151236	CVB 042-40 F16
GVJ	On Request	GVJ 042 F7

Finishes : F5 Electroless nickel (RoHS compliance)

Shell size	Part Number	Short Description
10SL	VS151237	CVB 042-10SL F5
14S	VS151238	CVB 042-14S F5
16S	VS151239	CVB 042-16S F5
16	VS151240	CVB 042-16 F5
18	VS151241	CVB 042-18 F5
20	VS151242	CVB 042-20 F5
22	VS151243	CVB 042-22 F5
24	VS151244	CVB 042-24 F5
28	VS151245	CVB 042-28 F5
32	VS151246	CVB 042-32 F5
36	VS151247	CVB 042-36 F5
40	VS151248	CVB 042-40 F5

Dimensions in mm

Caps for Threaded Connectors

CVS - Accessories For Connectors

Caps with chain for connectors version: shell type with threaded

Provided with sealing gasket. Chain and lugs are in stainless steel.

Protection degree: IP 67 (mated to the connector) according to EN 60529.

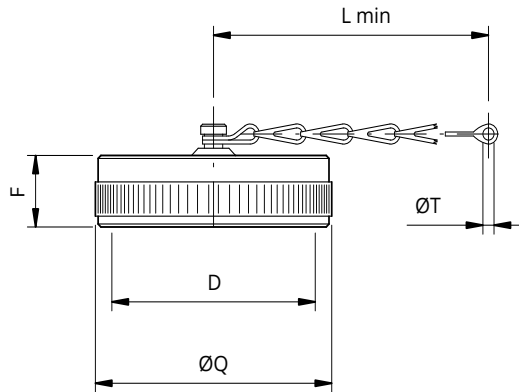

Shell size	D Thread in inches	ØQ	F	L min	ØT
10SL	5/8"-24 UNEF	24	13.1	108	4.3
14S	7/8"-20 UNEF	29	13.1	108	4.3
16S	1"-20 UNEF	30.5	13.1	108	4.3
16	1"-20 UNEF	30.5	13.1	123	4.3
18	1"1/8-18 UNEF	34	13.1	123	4.3
20	1"1/4-18 UNEF	37	13.1	123	4.3
22	1"3/8-18 UNEF	41	13.1	123	4.3
24	1"1/2-18 UNEF	43	13.1	123	4.3
28	1"3/4-18 UNEF	50	13.1	206	4.3
32	2"-18 UNS	56	14.7	206	4.3
36	2"1/4-16 UN	61	14.7	206	4.3
40	2"1/2-16 UN	69	14.7	206	4.3

Finishes : F7 Black epoxy varnish (RoHS compliance)

Shell size	Part Number	Short Description
10SL	VS150101	CVS 043-10SL F7
14S	VS150102	CVS 043-14S F7
16S	VS150103	CVS 043-16S F7
16	VS150104	CVS 043-16 F7
18	VS150105	CVS 043-18 F7
20	VS150106	CVS 043-20 F7
22	VS150107	CVS 043-22 F7
24	VS150108	CVS 043-24 F7
28	VS150109	CVS 043-28 F7
32	VS150110	CVS 043-32 F7
36	VS150111	CVS 043-36 F7
40	VS150112	CVS 043-40 F7

Finishes : F4 CCF - Green passivation - conductive

Shell size	Part Number	Short Description
10SL	VS150113	CVS 043-10SL F4
14S	VS150114	CVS 043-14S F4
16S	VS150115	CVS 043-16S F4
16	VS150116	CVS 043-16 F4
18	VS150117	CVS 043-18 F4
20	VS150118	CVS 043-20 F4
22	VS150119	CVS 043-22 F4
24	VS150120	CVS 043-24 F4
28	VS150121	CVS 043-28 F4
32	VS150122	CVS 043-32 F4
36	VS150123	CVS 043-36 F4
40	VS150124	CVS 043-40 F4

Finishes : F16 CCF - Black passivation (RoHS compliance) - conductive

Shell size	Part Number	Short Description
10SL	VS150125	CVS 043-10SL F16
14S	VS150126	CVS 043-14S F16
16S	VS150127	CVS 043-16S F16
16	VS150128	CVS 043-16 F16
18	VS150129	CVS 043-18 F16
20	VS150130	CVS 043-20 F16
22	VS150131	CVS 043-22 F16
24	VS150132	CVS 043-24 F16
28	VS150133	CVS 043-28 F16
32	VS150134	CVS 043-32 F16
36	VS150135	CVS 043-36 F16
40	VS150136	CVS 043-40 F16

Finishes : F5 Electroless nickel (RoHS compliance)

Shell size	Part Number	Short Description
10SL	VS150137	CVS 043-10SL F5
14S	VS150138	CVS 043-14S F5
16S	VS150139	CVS 043-16S F5
16	VS150140	CVS 043-16 F5
18	VS150141	CVS 043-18 F5
20	VS150142	CVS 043-20 F5
22	VS150143	CVS 043-22 F5
24	VS150144	CVS 043-24 F5
28	VS150145	CVS 043-28 F5
32	VS150146	CVS 043-32 F5
36	VS150147	CVS 043-36 F5
40	VS150148	CVS 043-40 F5

Dimensions in mm

Caps for Threaded Connectors

CVS - Accessories For Connectors

Caps with chain for connector version: shell type with coupling nut

These caps have no sealing gasket because mated with connectors generally provided with front gasket.

Chain and lugs are in stainless steel.

Protection degree: IP 67 (mated to the connector) according to EN 60529.

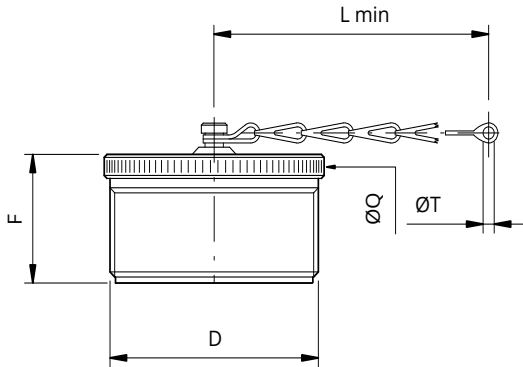

Shell size	D Thread in inches	ØQ	F	L min	ØT
10SL	5/8"-24 UNEF	18	16.5	108	4.3
14S	7/8"-20 UNEF	24	16.5	123	4.3
16S	1"-20 UNEF	27	16.5	123	4.3
16	1"-20 UNEF	27	21.4	123	4.3
18	1 1/8"-18 UNEF	30	21.4	123	4.3
20	1 1/4"-18 UNEF	34	21.4	138	4.3
22	1 3/8"-18 UNEF	37	21.4	138	4.3
24	1 1/2"-18 UNEF	40	21.4	138	4.3
28	1 3/4"-18 UNEF	46	21.4	206	4.3
32	2"-18 UNS	52.5	22.5	206	4.3
36	2 1/4"-16 UN	59	22.5	206	4.3
40	2 1/2"-16 UN	65	22.5	206	4.3

Finishes : F7 Black epoxy varnish (RoHS compliance)

Shell size	Part Number	Short Description
10SL	VS150201	CVS 042-10SL F7
14S	VS150202	CVS 042-14S F7
16S	VS150203	CVS 042-16S F7
16	VS150204	CVS 042-16 F7
18	VS150205	CVS 042-18 F7
20	VS150206	CVS 042-20 F7
22	VS150207	CVS 042-22 F7
24	VS150208	CVS 042-24 F7
28	VS150209	CVS 042-28 F7
32	VS150210	CVS 042-32 F7
36	VS150211	CVS 042-36 F7
40	VS150212	CVS 042-40 F7

Finishes : F4 CCF - Green passivation - conductive

Shell size	Part Number	Short Description
10SL	VS150213	CVS 042-10SL F4
14S	VS150214	CVS 042-14S F4
16S	VS150215	CVS 042-16S F4
16	VS150216	CVS 042-16 F4
18	VS150217	CVS 042-18 F4
20	VS150218	CVS 042-20 F4
22	VS150219	CVS 042-22 F4
24	VS150220	CVS 042-24 F4
28	VS150221	CVS 042-28 F4
32	VS150222	CVS 042-32 F4
36	VS150223	CVS 042-36 F4
40	VS150224	CVS 042-40 F4

Finishes : F16 CCF - Black passivation (RoHS compliance) - conductive

Shell size	Part Number	Short Description
10SL	VS150225	CVS 042-10SL F16
14S	VS150226	CVS 042-14S F16
16S	VS150227	CVS 042-16S F16
16	VS150228	CVS 042-16 F16
18	VS150229	CVS 042-18 F16
20	VS150230	CVS 042-20 F16
22	VS150231	CVS 042-22 F16
24	VS150232	CVS 042-24 F16
28	VS150233	CVS 042-28 F16
32	VS150234	CVS 042-32 F16
36	VS150235	CVS 042-36 F16
40	VS150236	CVS 042-40 F16

Finishes : F5 Electroless nickel (RoHS compliance)

Shell size	Part Number	Short Description
10SL	VS150237	CVS 042-10SL F5
14S	VS150238	CVS 042-14S F5
16S	VS150239	CVS 042-16S F5
16	VS150240	CVS 042-16 F5
18	VS150241	CVS 042-18 F5
20	VS150242	CVS 042-20 F5
22	VS150243	CVS 042-22 F5
24	VS150244	CVS 042-24 F5
28	VS150245	CVS 042-28 F5
32	VS150246	CVS 042-32 F5
36	VS150247	CVS 042-36 F5
40	VS150248	CVS 042-40 F5

Dimensions in mm

Protective Plastic Dust Caps

Accessories For Connectors

These caps are used to protect connectors against dust. They are not included in the connectors and have to be ordered separately.

The drawings are indicative only and they could be change according to the size

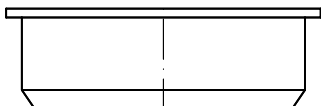

Caps for connectors version: shell type with ramp

Shell size	Part Number	Short Description
10SL	VS412110	PCVB 043-10
10SL (CVS version only)	VS412111	PCVS 043-10
14S	VS412112	PCV 043-14
16/16S	VS412113	PCV 043-16
18	VS412114	PCV 043-18
20	VS412115	PCV 043-20
22	VS412116	PCV 043-22
24	VS412117	PCV 043-24
28	VS412118	PCV 043-28
32	VS412119	PCV 043-32
36	VS412120	PCV 043-36
40	VS412121	PCV 043-40
GVJ	VS412122	PGVJ 043

Caps for connector version: shell type with coupling nut

Shell size	Part Number	Short Description
10SL	VS412123	PCVB 042-10
10SL (CVS version only)	VS412124	PCVS 042-10
14S	VS412125	PCV 042-14
16/16S	VS412126	PCV 042-16
18	VS412127	PCV 042-18
20	VS412128	PCV 042-20
22	VS412129	PCV 042-22
24	VS412130	PCV 042-24
28	VS412148	PCV 042-28
32	VS412144	PCV 042-32
36	VS412145	PCV 042-36
40	VS412146	PCV 042-40

Caps for connector version: shell type with rubber covered coupling nut

Shell size	Part Number	Short Description
10SL	VS412156	PCVBSG 042-10
14S	VS412157	PCVBSG 042-14
16S	VS412158	PCVBSG 042-16
18	VS412159	PCVBSG 042-18
20	VS412160	PCVBSG 042-20
22	VS412161	PCVBSG 042-22
24	VS412162	PCVBSG 042-24
28	VS412163	PCVBSG 042-28
32	VS412164	PCVBSG 042-32
36	VS412165	PCVBSG 042-36
40	VS412166	PCVBSG 042-40
GVJ	VS412147	PGVJ 042

Connector Closure Plate

CVS-CVB-CVBS-CVBSG-CVBR - Accessories For Connectors

Connector Closure Plate in stainless steel alloy provided with chloroprene rubber Gasket

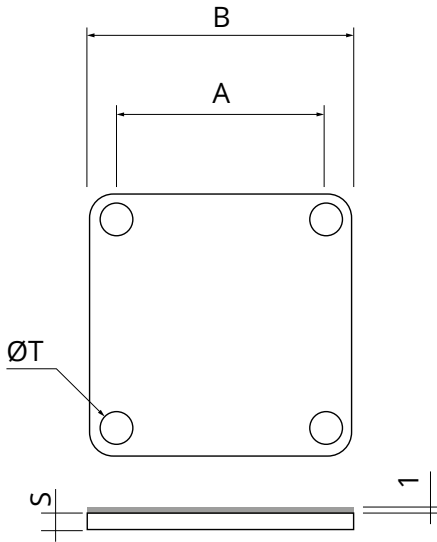

Plate and Gaskets for mounting panel connectors

Shell size	Part Number Non conductive	Short Description Non conductive	A ±0.1	B ±0.2	S	ØT
10SL	VS412521	C026-10	18.2	18.2	3	3.1
14S	VS412520	C026-14	23	23	3	3.1
16S/16	VS412519	C026-16	24.6	24.6	4	3.1
18	VS412518	C026-18	27	27	4	3.1
20	VS412517	C026-20	29.4	29.4	4	3.1
22	VS412516	C026-22	31.8	31.8	4	3.1
24	VS412515	C026-24	34.9	34.9	4	3.7
28	VS412514	C026-28	39.7	39.7	4	3.7
32	VS412513	C026-32	44.5	44.5	4	4.4
36	VS412512	C026-36	49.2	49.2	4	4.4
40	VS412511	C026-40	55.6	55.6	4	4.4

Dimensions in mm

Connector Mounting Gaskets

CVS-CVB-CVBS-CVBSG-CVBR - Accessories For Connectors

These gaskets are used to make panel connectors water resistant.

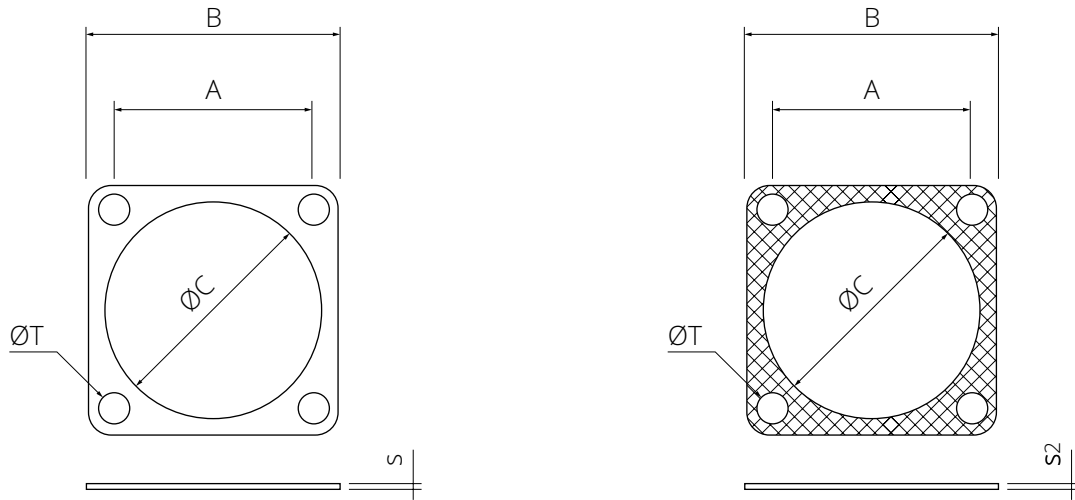

Gaskets for front mounting panel connectors (00 - 020 - 02 - 05 connectors):

- gasket C215: non conductive chloroprene rubber gasket (IP67 protection)
- gasket C215R: conductive chloroprene rubber gasket with embedded metal screen (IP65 protection).
These gaskets guarantee watertightness and RFI shielding

Shell size	Part Number Non conductive	Short Description Non conductive	Part Number Conductive	Short Description Conductive	A ±0.2	B -0 +0.4	ØC ±0.3	S C215	S2 C215R	ØT ±0.3
10SL	VS412301	C215-10	VS412351	C215R-10	18.2	25.4	16.3	1±0.3	0.5±0.2	4.3
14S	VS412302	C215-14	VS412352	C215R-14	23	30.2	22.2	1±0.3	0.5±0.2	4.3
16S/16	VS412303	C215-16	VS412353	C215R-16	24.6	32.5	25.4	1±0.3	0.5±0.2	4.3
18	VS412304	C215-18	VS412354	C215R-18	27	35	28.6	1±0.3	0.5±0.2	5.1
20	VS412305	C215-20	VS412355	C215R-20	29.4	38.1	31.8	1±0.3	0.5±0.2	5.1
22	VS412306	C215-22	VS412356	C215R-22	31.8	41.2	34.9	1±0.3	0.5±0.2	5.1
24	VS412307	C215-24	VS412357	C215R-24	34.9	44.5	38.1	1±0.3	0.5±0.2	5.1
28	VS412308	C215-28	VS412358	C215R-28	39.7	50.8	44.5	1±0.3	0.5±0.2	5.1
32	VS412309	C215-32	VS412359	C215R-32	44.5	57	50.8	1±0.3	0.5±0.2	5.5
36	VS412314	C215-36	VS412360	C215R-36	49.2	63.5	55.6	1±0.3	0.5±0.2	5.5
40	VS412315	C215-40	VS412361	C215R-40	55.5	69.9	61.9	1±0.3	0.5±0.2	5.5

Gaskets for rear mounting panel connectors (03 - 030 - 038 connectors):

- gasket C216: non conductive chloroprene rubber gasket (IP67 protection)
- gasket C216R: conductive chloroprene rubber gasket with embedded metal screen (IP65 protection).
These gaskets guarantee watertightness and RFI shielding

Shell size	Part Number Non conductive	Short Description Non conductive	Part Number Conductive	Short Description Conductive	A ±0.2	B -0 +0.4	ØC ±0.3	S C216	S2 C216R	ØT ±0.3
10SL	VS412401	C216-10	VS412451	C216R-10	18.2	25.4	18.2	0.8±0.3	0.5±0.2	4.2
14S	VS412402	C216-14	VS412452	C216R-14	23	30.2	24.6	0.8±0.3	0.5±0.2	4.2
16S/16	VS412403	C216-16	VS412453	C216R-16	24.6	32.5	27.4	0.8±0.3	0.5±0.2	4.2
18	VS412404	C216-18	VS412454	C216R-18	27	35	30.8	0.8±0.3	0.5±0.2	4.2
20	VS412405	C216-20	VS412455	C216R-20	29.4	38.1	34.2	0.8±0.3	0.5±0.2	4.2
22	VS412406	C216-22	VS412456	C216R-22	31.8	41.2	37.4	0.8±0.3	0.5±0.2	4.2
24	VS412407	C216-24	VS412457	C216R-24	34.9	44.5	40.9	0.8±0.3	0.5±0.2	4.2
28	VS412408	C216-28	VS412458	C216R-28	39.7	50.8	46.7	0.8±0.3	0.5±0.2	5.1
32	VS412409	C216-32	VS412459	C216R-32	44.5	57	53.4	0.8±0.3	0.5±0.2	5.1
36	VS412410	C216-36	VS412460	C216R-36	49.2	63.5	59.6	0.8±0.3	0.5±0.2	5.1
40	VS412411	C216-40	VS412461	C216R-40	55.5	69.9	65.5	0.8±0.3	0.5±0.2	5.1

On request: RF flame resistant gasket, (V) Fluoride rubber or (S) silicone gaskets.
These gaskets are not needed by GVJ connectors.

Dimensions in mm

G3 Shielded Gaskets

CVS-CVB-CVBS-CVBSG-CVBR - Accessories For Connectors

Gaskets C215G3 and C216G3: conductive silicone gaskets with embedded metal screen. These gaskets guarantee watertightness and RFI shielding

- Elastomer binder: Silicone
- Conductive filler: Nickel Graphite
- Color: Gray
- Operating Temperature range: -60 °C ÷ +220 °C
- Flammability Rating: UL 94-V0
- Salt spray test > 96 h (consult our sales office for details)
- IP67 protection (EN 60529)

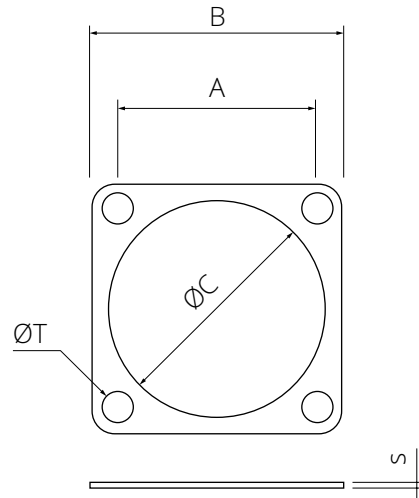

C215 Gaskets for front mounting panel connectors (00 - 020 - 02 connectors):

Shell size	Part Number Conductive	Short Description Conductive	A ±0.2	B -0 +0.4	ØC ±0.3	S C215G3	ØT ±0.3
10SL	VS412331	C215G3-10	18.2	25.4	16.3	0.8±0.2	4.3
14S	VS412332	C215G3-14	23	30.2	22.2	0.8±0.2	4.3
16S/16	VS412333	C215G3-16	24.6	32.5	25.4	0.8±0.2	4.3
18	VS412334	C215G3-18	27	35	28.6	0.8±0.2	5.1
20	VS412335	C215G3-20	29.4	38.1	31.8	0.8±0.2	5.1
22	VS412336	C215G3-22	31.8	41.2	34.9	0.8±0.2	5.1
24	VS412337	C215G3-24	34.9	44.5	38.1	0.8±0.2	5.1
28	VS412338	C215G3-28	39.7	50.8	44.5	0.8±0.2	5.1
32	VS412339	C215G3-32	44.5	57	50.8	0.8±0.2	5.5
36	VS412340	C215G3-36	49.2	63.5	55.6	0.8±0.2	5.5
40	VS412341	C215G3-40	55.5	69.9	61.9	0.8±0.2	5.5

C216 Gaskets for rear mounting panel connectors (03 - 030 - 038 connectors):

Shell size	Part Number Conductive	Short Description Conductive	A ±0.2	B -0 +0.4	ØC ±0.3	S C216G3	ØT ±0.3
10SL	VS412431	C216G3-10	18.2	25.4	18.2	0.8±0.2	4.2
14S	VS412432	C216G3-14	23	30.2	24.6	0.8±0.2	4.2
16S/16	VS412433	C216G3-16	24.6	32.5	27.4	0.8±0.2	4.2
18	VS412434	C216G3-18	27	35	30.8	0.8±0.2	4.2
20	VS412435	C216G3-20	29.4	38.1	34.2	0.8±0.2	4.2
22	VS412436	C216G3-22	31.8	41.2	37.4	0.8±0.2	4.2
24	VS412437	C216G3-24	34.9	44.5	40.9	0.8±0.2	4.2
28	VS412438	C216G3-28	39.7	50.8	46.7	0.8±0.2	5.1
32	VS412439	C216G3-32	44.5	57	53.4	0.8±0.2	5.1
36	VS412440	C216G3-36	49.2	63.5	59.6	0.8±0.2	5.1
40	VS412441	C216G3-40	55.5	69.9	65.5	0.8±0.2	5.1

Dimensions in mm

Cable-Clamps A type

CVS-CVB-CVBS-CVBSG-CVBR - Accessories For Connectors

MS 3057 - ...A Cable-Clamps, general duty

These Cable-Clamps keep the cable in the connector axial position and guarantee an excellent mechanical strain relief.

MS 3420 or RF 3420 Bushing are not waterproof and are generally supplied separately except for classes AF,F,LAF and LF connectors.

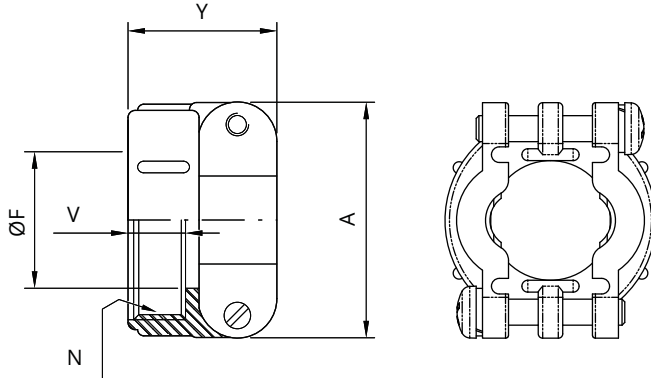

Finishes : F7 Black epoxy varnish (RoHS compliance)

Shell size	Part Number	Short Description	Y max	V ±0.2	A max	ØF max cable Ø	N Thread in inches
10SL	VS705201	MS 3057-4A F7	20.6	10.5	22.5	8	5/8"-24 UNEF
14S	VS705202	MS 3057-6A F7	22.2	10.5	28	11	3/4"-20 UNEF
16S -16	VS705203	MS 3057-8A F7	25	10.5	30	14.2	7/8"-20 UNEF
18	VS705204	MS 3057-10A F7	25	10.5	31.7	15.8	1"-20 UNEF
20 - 22	VS705205	MS 3057-12A F7	25	10.5	37.5	19	1" 3/16-18 UNEF
24 - 28	VS705206	MS 3057-16A F7	26	10.5	43.5	23.8	1" 7/16-18 UNEF
32	VS705207	MS 3057-20A F7	28	12.5	51.7	31.7	1" 3/4-18 UNS
36	VS705208	MS 3057-24A F7	29.4	14	58.5	35	2"-18 UNS
40	VS705209	MS 3057-28A F7	42.8	14	68.5	41.2	2"1/4-16 UN

Finishes : F4 CCF - Green passivation - conductive

Shell size	Part Number	Short Description	Y max	V ±0.2	A max	ØF max cable Ø	N Thread in inches
10SL	VS705211	MS 3057-4A F4	20.6	10.5	22.5	8	5/8"-24 UNEF
14S	VS705212	MS 3057-6A F4	22.2	10.5	28	11	3/4"-20 UNEF
16S -16	VS705213	MS 3057-8A F4	25	10.5	30	14.2	7/8"-20 UNEF
18	VS705214	MS 3057-10A F4	25	10.5	31.7	15.8	1"-20 UNEF
20 - 22	VS705215	MS 3057-12A F4	25	10.5	37.5	19	1" 3/16-18 UNEF
24 - 28	VS705216	MS 3057-16A F4	26	10.5	43.5	23.8	1" 7/16-18 UNEF
32	VS705217	MS 3057-20A F4	28	12.5	51.7	31.7	1" 3/4-18 UNS
36	VS705218	MS 3057-24A F4	29.4	14	58.5	35	2"-18 UNS
40	VS705219	MS 3057-28A F4	42.8	14	68.5	41.2	2"1/4-16 UN

Finishes : F16 CCF - Black passivation (RoHS compliance) - conductive

Shell size	Part Number	Short Description	Y max	V ±0.2	A max	ØF max cable Ø	N Thread in inches
10SL	VS705221	MS 3057-4A F16	20.6	10.5	22.5	8	5/8"-24 UNEF
14S	VS705222	MS 3057-6A F16	22.2	10.5	28	11	3/4"-20 UNEF
16S -16	VS705223	MS 3057-8A F16	25	10.5	30	14.2	7/8"-20 UNEF
18	VS705224	MS 3057-10A F16	25	10.5	31.7	15.8	1"-20 UNEF
20 - 22	VS705225	MS 3057-12A F16	25	10.5	37.5	19	1" 3/16-18 UNEF
24 - 28	VS705226	MS 3057-16A F16	26	10.5	43.5	23.8	1" 7/16-18 UNEF
32	VS705227	MS 3057-20A F16	28	12.5	51.7	31.7	1" 3/4-18 UNS
36	VS705228	MS 3057-24A F16	29.4	14	58.5	35	2"-18 UNS
40	VS705229	MS 3057-28A F16	42.8	14	68.5	41.2	2"1/4-16 UN

Finishes : F5 Electroless nickel (RoHS compliance)

Shell size	Part Number	Short Description	Y max	V ±0.2	A max	ØF max cable Ø	N Thread in inches
10SL	VS705231	MS 3057-4A F5	20.6	10.5	22.5	8	5/8"-24 UNEF
14S	VS705232	MS 3057-6A F5	22.2	10.5	28	11	3/4"-20 UNEF
16S -16	VS705233	MS 3057-8A F5	25	10.5	30	14.2	7/8"-20 UNEF
18	VS705234	MS 3057-10A F5	25	10.5	31.7	15.8	1"-20 UNEF
20 - 22	VS705235	MS 3057-12A F5	25	10.5	37.5	19	1" 3/16-18 UNEF
24 - 28	VS705236	MS 3057-16A F5	26	10.5	43.5	23.8	1" 7/16-18 UNEF
32	VS705237	MS 3057-20A F5	28	12.5	51.7	31.7	1" 3/4-18 UNS
36	VS705238	MS 3057-24A F5	29.4	14	58.5	35	2"-18 UNS
40	VS705239	MS 3057-28A F5	42.8	14	68.5	41.2	2"1/4-16 UN

Dimensions in mm

Bushing for Cable-Clamps A type

CVS-CVB-CVBS-CVBSG-CVBR - Accessories For Connectors

MS 3420 - ... - RF 3420 - ... Bushing

They are made of elastomeric rubber and used with Cable-Clamps MS3057 - ...A to protect the cable.

In the same Cable-Clamps it is possible to assemble more than one bushing (inside each other) so to achieve diameters much smaller than the nominal.

Available in two versions:

- MS 3420 - ... in neoprene rubber.
- RF 3420 - ... in flame resistant rubber.

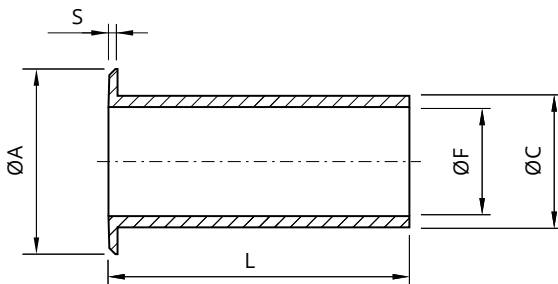

Neoprene rubber

Shell size	Part Number	Short Description	For Cable gland	ØA ±0.4	ØF ±0.4	ØC ±0.4	S ±0.4	L ±0.4
10SL	VS705401	MS 3420-4	MS 3057-4A	12.8	5.6	7.6	1.6	69.8
14S	VS705402	MS 3420-6	MS 3057-6A	15.7	7.9	10.8	1.6	66.8
16S -16	VS705403	MS 3420-8	MS 3057-8A	18.8	11	14	1.6	63.5
18	VS705404	MS 3420-10	MS 3057-10A	22	14.2	15.6	1.6	60.3
20 - 22	VS705405	MS 3420-12	MS 3057-12A	27	15.8	18.8	1.6	57.1
24 - 28	VS705406	MS 3420-16	MS 3057-16A	33.3	19	23.6	1.6	53.9
32	VS705407	MS 3420-20	MS 3057-20A	40.5	23.8	31.5	1.6	50.8
36	VS705408	MS 3420-24	MS 3057-24A	46.9	31.7	34.8	1.6	47.6
40	VS705409	MS 3420-28	MS 3057-28A	52.9	34.9	41	1.6	44.4

Flame resistant rubber

Shell size	Part Number	Short Description	For Cable gland	ØA ±0.4	ØF ±0.4	ØC ±0.4	S ±0.4	L ±0.4
14S	VS705412	RF 3420-6	MS 3057-6A	15.7	7.9	10.8	1.6	66.8
16S -16	VS705413	RF 3420-8	MS 3057-8A	18.8	11	14	1.6	63.5
18	VS705414	RF 3420-10	MS 3057-10A	22	14.2	15.6	1.6	60.3
20 - 22	VS705415	RF 3420-12	MS 3057-12A	27	15.8	18.8	1.6	57.1
24 - 28	VS705416	RF 3420-16	MS 3057-16A	33.3	19	23.6	1.6	53.9
32	VS705417	RF 3420-20	MS 3057-20A	40.5	23.8	31.5	1.6	50.8
36	VS705418	RF 3420-24	MS 3057-24A	46.9	31.7	34.8	1.6	47.6
40	VS705419	RF 3420-28	MS 3057-28A	52.9	34.9	41	1.6	44.4

On request: V = Fluoride Rubber S = Silicone Rubber

Dimensions in mm

Cable-Clamps C type

CVS-CVB-CVBS-CVBSG-CVBR - GVJ - Accessories For Connectors

IP67

MS 3057 - ...C - RF 3057 - ...C water tight Cable-Clamps

Besides guaranteeing an excellent mechanical strain relief keeping the cable in the centre of the connector, these Cable-Clamps are provided with an internal conical rubber bushing ensuring waterproof protection. The screws in stainless steel have elastic rose-cut antivibration head.

Available in two versions:

- MS 3057 - ...C with gasket in neoprene rubber.
- RF 3057 - ...C with gasket in flame resistant rubber.

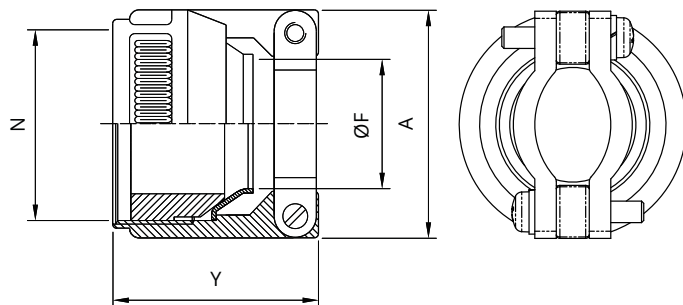

Type	Shell size	Y max	A max	ØF min	ØF max	N Thread in inches
4C	10SL	33.4	23	2.4	7.9	5/8"-24 UNEF
6C	14S	32.3	26	5.8	11.2	3/4"-20 UNEF
8C	16S -16	32.3	28.5	8	13.5	7/8"-20 UNEF
10C	18	35	32	9.6	15.9	1"-20 UNEF
12C	20 - 22	35.7	37.5	11.3	19	1" 3/16-18 UNEF
16C	24 - 28	39	43.5	15.5	23.8	1" 7/16-18 UNEF
20C	32	44.8	54	23.4	31.8	1" 3/4-18 UNS
24C	36	52	58	25.4	35	2"-18 UNS
28C	40 - GVJ	52.3	63.5	30	41.3	2"1/4-16 UN

Finishes : F7 Black epoxy varnish (RoHS compliance)

Shell size	Part Number	Short Description	Part Number	Short Description
		neoprene rubber		flame resistant rubber
10SL	VS705251	MS 3057-4C F7	VS705301	RF 3057-4C F7
14S	VS705252	MS 3057-6C F7	VS705302	RF 3057-6C F7
16S -16	VS705253	MS 3057-8C F7	VS705303	RF 3057-8C F7
18	VS705254	MS 3057-10C F7	VS705304	RF 3057-10C F7
20 - 22	VS705255	MS 3057-12C F7	VS705305	RF 3057-12C F7
24 - 28	VS705256	MS 3057-16C F7	VS705306	RF 3057-16C F7
32	VS705257	MS 3057-20C F7	VS705307	RF 3057-20C F7
36	VS705258	MS 3057-24C F7	VS705308	RF 3057-24C F7
40 - GVJ	VS705259	MS 3057-28C F7	VS705309	RF 3057-28C F7

Finishes : F4 CCF - Green passivation - conductive

Shell size	Part Number	Short Description	Part Number	Short Description
		neoprene rubber		flame resistant rubber
10SL	VS705261	MS 3057-4C F4	VS705311	RF 3057-4C F4
14S	VS705262	MS 3057-6C F4	VS705312	RF 3057-6C F4
16S -16	VS705263	MS 3057-8C F4	VS705313	RF 3057-8C F4
18	VS705264	MS 3057-10C F4	VS705314	RF 3057-10C F4
20 - 22	VS705265	MS 3057-12C F4	VS705315	RF 3057-12C F4
24 - 28	VS705266	MS 3057-16C F4	VS705316	RF 3057-16C F4
32	VS705267	MS 3057-20C F4	VS705317	RF 3057-20C F4
36	VS705268	MS 3057-24C F4	VS705318	RF 3057-24C F4
40	VS705269	MS 3057-28C F4	VS705319	RF 3057-28C F4

Finishes : F16 CCF - Black passivation (RoHS compliance) - conductive

Shell size	Part Number	Short Description	Part Number	Short Description
		neoprene rubber		flame resistant rubber
10SL	VS705271	MS 3057-4C F16	VS705321	RF 3057-4C F16
14S	VS705272	MS 3057-6C F16	VS705322	RF 3057-6C F16
16S -16	VS705273	MS 3057-8C F16	VS705323	RF 3057-8C F16
18	VS705274	MS 3057-10C F16	VS705324	RF 3057-10C F16
20 - 22	VS705275	MS 3057-12C F16	VS705325	RF 3057-12C F16
24 - 28	VS705276	MS 3057-16C F16	VS705326	RF 3057-16C F16
32	VS705277	MS 3057-20C F16	VS705327	RF 3057-20C F16
36	VS705278	MS 3057-24C F16	VS705328	RF 3057-24C F16
40 - GVJ	VS705279	MS 3057-28C F16	VS705329	RF 3057-28C F16

Finishes : F5 Electroless nickel (RoHS compliance)

Shell size	Part Number	Short Description
		neoprene rubber
10SL	VS705281	MS 3057-4C F5
14S	VS705282	MS 3057-6C F5
16S -16	VS705283	MS 3057-8C F5
18	VS705284	MS 3057-10C F5
20 - 22	VS705285	MS 3057-12C F5
24 - 28	VS705286	MS 3057-16C F5
32	VS705287	MS 3057-20C F5
36	VS705288	MS 3057-24C F5
40	VS705289	MS 3057-28C F5

Gasket on request: V = Fluoride Rubber - S = Silicone Rubber

Dimensions in mm

Bushing for Cable-Clamps C type

CVS-CVB-CVBS-CVBSG-CVBR - GVJ - Accessories For Connectors

MS 3420 - ...A - RF 3420 - ...A Bushing

They are made of elastomeric rubber and used with Cable-Clamps MS 3057 - ...C to protect the cable. They allow using cables with diameter smaller than the nominal.

Available in two versions:

- MS 3420 - ...A in neoprene rubber.
- RF 3420 - ...A in flame resistant rubber (on request).

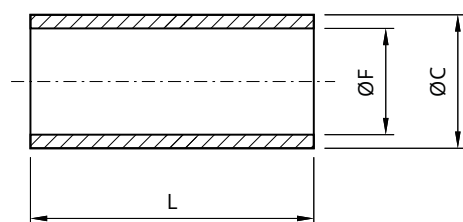

Neoprene rubber

Shell size	Part Number	Short Description	For Cable gland	ØF ±0.4	ØC ±0.4	L ±0.8
10SL	VS705421	MS 3420-4A	MS 3057-4C	5.6	7.8	50.8
14S	VS705422	MS 3420-6A	MS 3057-6C	7.9	11	50.8
16S -16	VS705423	MS 3420-8A	MS 3057-8C	11.1	13.6	50.8
18	VS705424	MS 3420-10A	MS 3057-10C	11.1	15.8	50.8
20 - 22	VS705425	MS 3420-12A	MS 3057-12C	13.7	18.9	50.8
24 - 28	VS705426	MS 3420-16A	MS 3057-16C	19	23.7	50.8
32	VS705427	MS 3420-20A	MS 3057-20C	23.8	31.6	50.8
36	VS705428	MS 3420-24A	MS 3057-24C	28.5	35	50.8
40 - GVJ	VS705429	MS 3420-28A	MS 3057-28C	31.8	41.1	50.8

Flame resistant rubber

Shell size	Part Number	Short Description	For Cable gland	ØF ±0.4	ØC ±0.8	L ±2
10SL	VS705431	RF 3420-4A	RF 3057-4C	5.6	7.8	50.8
14S	VS705432	RF 3420-6A	RF 3057-6C	7.9	11	50.8
16S -16	VS705433	RF 3420-8A	RF 3057-8C	11.1	13.6	50.8
18	VS705434	RF 3420-10A	RF 3057-10C	11.1	15.8	50.8
20 - 22	VS705435	RF 3420-12A	RF 3057-12C	13.7	18.9	50.8
24 - 28	VS705436	RF 3420-16A	RF 3057-16C	19	23.7	50.8
32	VS705437	RF 3420-20A	RF 3057-20C	23.8	31.6	50.8
36	VS705438	RF 3420-24A	RF 3057-24C	28.5	35	50.8
40 - GVJ	VS705439	RF 3420-28A	RF 3057-28C	31.8	41.1	50.8

On request: V = Fluoride Rubber S = Silicone Rubber

Dimensions in mm

Cable Glands - PG or metric threaded

Accessories For Connectors



PG or metric threaded Cable Glands



Cable Glands with protection for spiral-shaped cables

These Cable Glands guarantee an excellent strain relief resistance with waterproof protection (IP68 and IP69). The body is in plastic material (Polyamide or black coloured Nylon – Operating temperature -25 °C to + 100 °C) or metallic material (Brass with nickel finish – operating temperature -30 °C to +100 °C).

They both prevent the cable from twisting when coupling the connectors. The plastic version is provided with an anti-vibration system to prevent the Cable Glands from becoming loose. Compared to other cable retention systems this solution is more economical.

These adapters are available with PG or metric thread and can be used with connector classes DA...PG, DA...M, RA...PG and RA...M. Cable Glands with protection for spiral-shaped cables (only for PG sizes 7 to 21 or metric 12 to 32) are available on request. They eliminate possible damage caused by the cable bending on the cable-connector interface. Therefore these are often used with cables where a small conductor can be easily damaged.

Plastic Cable Glands

Part Number	Short Description	Part Number Protected	Short Description Protected	V	ØS Clamping range	K	Z	L	L1
VS705021	AL PG7 P	VS705041	AL PG7 PP	PG 7	2.5-6.5	15	8	32	62
VS705022	AL PG9 P	VS705042	AL PG9 PP	PG 9	3.5-8	19	8	36	73.5
VS705023	AL PG11 P	VS705043	AL PG11 PP	PG 11	4-10	22	8	38	86
VS705024	AL PG13.5 P	VS705044	AL PG13.5 PP	PG 13.5	6-12	24	9	41	98
VS705025	AL PG16 P	VS705045	AL PG16 PP	PG 16	9-14	27	10	44	111.5
VS705026	AL PG21 P	VS705046	AL PG21 PP	PG 21	13-18	33	11	49	129
VS705027	AL PG29 P	-	-	PG 29	14-25	42	11	56	
VS705028	AL PG36 P	-	-	PG 36	24-32	53	13	66	
VS705029	AL PG42 P	-	-	PG 42	35-38	60	13	68	
VS705031	AL M12 P	VS705051	AL M12 PP	M12x1.5	3.5-7	15	8	30	64
VS705032	AL M16 P	VS705052	AL M16 PP	M16x1.5	4.5-10	19	8	34	86
VS705033	AL M20 P	VS705053	AL M20 PP	M20x1.5	7-13	25	9	37	101
VS705034	AL M25 P	VS705054	AL M25 PP	M25x1.5	9-17	30	10	40	125
VS705035	AL M32 P	VS705055	AL M32 PP	M32x1.5	11-21	36	10	47	149
VS705036	AL M40 P	-	-	M40x1.5	19-28	46	10	52	
VS705037	AL M50 P	-	-	M50x1.5	27-35	55	12	62	

Dimensions in mm

Cable Glands - PG or metric threaded

Accessories For Connectors

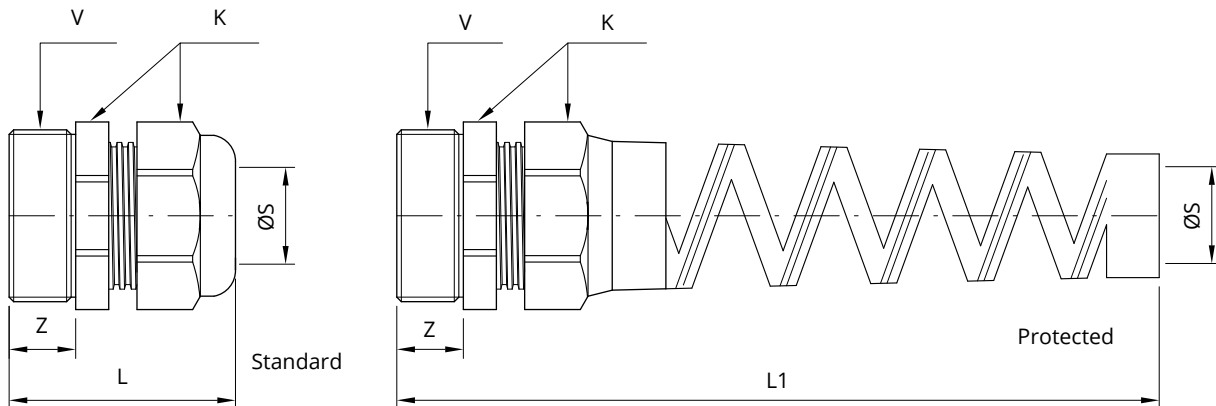

Metallic Cable Glands

Part Number	Short Description	V	ØS Clamping range	K	Z	L
VS705001	AL PG7 M	PG 7	2-6.5	15	8	32
VS705002	AL PG9 M	PG 9	3-8	19	8	36
VS705003	AL PG11 M	PG 11	4-10	22	8	38
VS705004	AL PG13.5 M	PG 13.5	5-12	24	9	41
VS705005	AL PG16 M	PG 16	8-14	27	10	44
VS705006	AL PG21 M	PG 21	11-18	33	11	49
VS705007	AL PG29 M	PG 29	16-25	42	11	56
VS705008	AL PG36 M	PG 36	19-32	53	13	66
VS705009	AL PG42 M	PG 42	28-38	60	13	68
VS705011	AL M12 M	M12x1.5	3.5-7	15	8	30
VS705012	AL M16 M	M16x1.5	4.5-10	19	8	34
VS705013	AL M20 M	M20x1.5	7-13	25	9	37
VS705014	AL M25 M	M25x1.5	9-17	30	10	40
VS705015	AL M32 M	M32x1.5	11-21	36	10	47
VS705016	AL M40 M	M40x1.5	19-28	46	10	52
VS705017	AL M50 M	M50x1.5	27-35	55	12	62

Metallic Cable Glands - Shielded

Part Number	Short Description	V	ØS Clamping range	K	Z	L
On Request	AL M12 E	M12x1.5	3.5-7	16	6.5	26.5
On Request	AL M16 E	M16x1.5	4.5-9	20	7	33
On Request	AL M20 E	M20x1.5	7-13	24	8	37
On Request	AL M25 E	M25x1.5	9-17	29	8	38.5
VS705067	AL M32 E	M32x1.5	11-21	36	9	45.5
On Request	AL M40 E	M40x1.5	19-28	45	9	48
On Request	AL M50 E	M50x1.5	27-35	54	10	55.5

Metallic Cable Glands - Short

Part Number	Short Description	V	ØS Clamping range	K	Z	L
On Request	AL M25 S	M25x1.5	11-18	30	5	37
On Request	AL M32 S	M32x1.5	16-25	40	5	43

Dimensions in mm

Contacts hole plugs for inserts

Accessories For Connectors

These are employed when not all contact cavities of inserts are used.

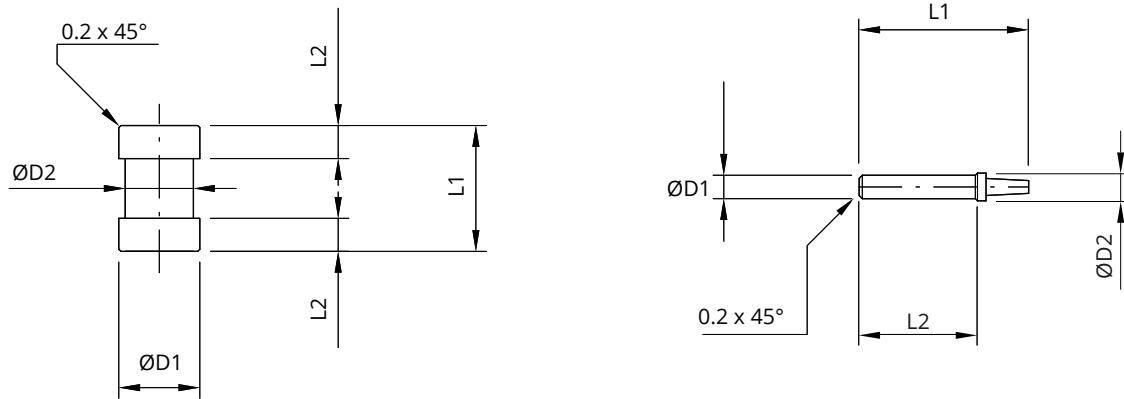

* Size 20 / 16

Contact size	Part Number	Short Description	ØD1	ØD2	L1	L2
20	VS412501	A HP 20 I	1.6	2.3	14	11
18*	VS412502	A HP 18 I	-	-	-	-
16 - 16S	VS412503	A HP 16 I	2.2	2.6	15.8	10.8
12	VS412504	A HP 12 I	4.55	3.7	11.95	3.15
8	VS412505	A HP 8 I	7.6	6.4	11.8	3.1
4	VS412506	A HP 4 I	10.9	9.7	11.8	3.1
0	VS412507	A HP 0 I	15	13.5	14.3	4.3
4/0*	VS412508	A HP 4/0 I	-	-	-	-

* On request

Wire hole plugs for grommets on request

Dimensions in mm

Contact Crimp Tools



For the instructions concerning assembly and crimping of contacts please consult the appropriate manuals.

We recommend to respect the following general rules:

- always use the tools recommended by Van-System's catalogue or manuals
- apply the suggested norms for tool maintenance and calibration
- always use the guide pin when installing the Socket contacts size 20 - 18 - 16 and 12

When installing the contacts in the insert, use isopropyl alcohol as lubricant or the appropriate liquid.

DO NOT USE ALTERNATIVE GREASES OR OILS which could damage the insert and affect the functionality of the connector.

Part Number	Short Description	Tool
VS610001	CRT-HT120	Crimping Tool Cembre HT 120
VS610002	CRT-784/1	Crimping Tool Daniels DMC VM8
VS610003	CRT-HT45	Crimping Tool Cembre HT 45
VS610004	PCT-784	Crimping Tool Daniels DMC WA27F
VS610005	PCT-784A	Crimping Tool Daniels
VS610006	LOC-784-20	Locator (for contacts size 20) Daniels TH1A
VS610007	LOC-784-18	Locator (for contacts size 18)
VS610008	LOC-784	Locator (for ST485 contacts size 16 and 12) Daniels TURRET VH435-1
VS610009	CDI-ME1	Crimping Die Cembre ME1
VS610010	CDI-ME2	Crimping Die Cembre ME2
VS610011	CDI-ME3	Crimping Die Cembre ME3
VS610012	CDI-ME5	Crimping Die Cembre ME5
VS610013	CDI-ME14	Crimping Die Cembre M14
VS610014	CDI-ME24C	Crimping Die Cembre M24C
VS610015	CDI-ME29C	Crimping Die Cembre M29C
VS610016	LOC-KVBS-784	Locator (for KT485 contacts)
VS610017	FP-784	Foot Pedal for PCT-784 Daniels WA 10A
VS610018	AB-784	Adjustable Base Mount for PCT-784 Daniels BM2A
VS610019	CTIN-784-18/20	Insertion Tool (for ST485 contacts size 18, 20 and 16-13)
VS610020	CTIN-784-16	Insertion Tool (for ST485 contacts size 16)
VS610021	CTIN-784-18	Insertion Tool (for ST485 contacts size 18)
VS610022	CTIN-784-12/1	Insertion Tool (for ST485 xx-30, xx-38)
VS610023	CTIN-784-12	Insertion Tool (for ST485 contacts size 12)
VS610024	CTIN-784-8	Insertion Tool (for ST485 contacts size 8)
VS610025	CTIN-784-4	Insertion Tool (for ST485 contacts size 4)
VS610026	CTIN-784-4/2	Insertion Tool (for ST485 4-58)
VS610027	CTIN-784-4/1	Insertion Tool (for ST485 xx-62)
VS610028	CTIN-784-0/1	Insertion Tool (for ST485 xx-78 and xx-90)
VS610029	CTIN-784-0	Insertion Tool (for ST485 contacts size 0)
VS610030	CTES-784-20	Removal Tool (for ST485 contacts size 20)
VS610031	CTES-784-18	Removal Tool (for ST485 contacts size 18)
VS610032	CTES-784-16	Removal Tool (for ST485 contacts size 16)
VS610033	CTES-784-12	Removal Tool (for ST485 contacts size 12)
VS610034	CTES-784-8	Removal Tool (for ST485 contacts size 8)
VS610035	CTES-784-4	Removal Tool (for ST485 contacts size 4)
VS610036	CTES-784-0	Removal Tool (for ST485 contacts size 0)
VS610038	CTES-784-4/0	Removal Tool (for ST485 contacts size 4/0)
VS610040	KTES-784-16	Removal Tool (for KT contacts size 16)
VS610041	KTES-784-12	Removal Tool (for KT contacts size 12)
VS610042	KTES-784-8	Removal Tool (for KT contacts size 8)
VS610043	KTRS-784-12	Tool to close retention spring (for KT contacts size 12)
VS610048	CRT-HT131	Crimping Tool HT 131 C
VS610049	CDI-ME48C	Crimping Die Cembre ME48C
VS610050	CDI-ME60C	Crimping Die Cembre ME60C
VS610051	CDI-VS61137	Crimping Die (for ST485 contacts size 8-22)
VS610052	GP-784-20	Guide Pin Size 20
VS610053	GP-784-18	Guide Pin Size 18
VS610054	GP-784-16	Guide Pin Size 16
VS610055	GP-784-12	Guide Pin Size 12
VS610056	CDI-VS61138	Crimping Die (for KT485 contacts size 8-38)
VS610059	CDI-ME37C	Crimping Die Cembre ME37C
VS610060	CDI-ME17C	Crimping Die Cembre ME17C
VS610061	CDI-ME20C	Crimping Die Cembre ME20C
VS610062	CDI-ME30C	Crimping Die Cembre ME30C
VS610077	CDI-ME7	Crimping Die Cembre ME7

Contact ST Crimp Tools

CVS-CVB-CVBS-CVBSG-CVBR-GVJ (For Rubber Insert)

Contact size	Short Description	mm ² section	AWG section	Manual crimp tool	Pneumatic crimp tool	Locator /Die	Insertion tool	Removal tool	Guide pin	Stripping length mm
20	ST485 20P/1/S	0.15÷0.3	26÷22	CRT-784/1	PCT-784	LOC-784-20	CTIN-784-18/20	CTES-784-20	GP-784-20	4
20	ST485 20P/2	0.15÷0.3	26÷22	CRT-784/1	PCT-784	LOC-784-20	CTIN-784-18/20	CTES-784-20	**	4
20	ST485 20P/3	0.15÷0.3	26÷22	CRT-784/1	PCT-784	LOC-784-20	CTIN-784-18/20	CTES-784-20	**	4
18	ST485 18P/S	0.15÷0.6	26÷20	CRT-784/1	PCT-784	LOC-784-18	CTIN-784-18/20	CTES-784-18	GP-784-18	4.5
16S	ST485 16SP/S	1÷1.5	18÷16	CRT-784/1	PCT-784	LOC-784	CTIN-784-16	CTES-784-16	GP-784-16	6.3
16S	ST485 16S-11P/S	0.25÷0.5	22-20	CRT-784/1	PCT-784	LOC-784	CTIN-784-16	CTES-784-16	GP-784-16	6.3
16S	ST485 16S-12P/S	0.15÷0.75	20	CRT-784/1	PCT-784	LOC-784	CTIN-784-16	CTES-784-16	GP-784-16	6.3
16S	ST485 16S-15P/S	0.75÷1	18	CRT-784/1	PCT-784	LOC-784	CTIN-784-16	CTES-784-16	GP-784-16	6.3
16S	ST485 16S-17P/S	0.75	16	**	**	**	**	**	**	6.3
16S	ST485 16S-20P/S	1÷2	18÷14	CRT-784/1	PCT-784	LOC-784	CTIN-784-16	CTES-784-16	GP-784-16	6.3
16S	ST485 16S-26P/S	2.5÷3	12	CRT-784/1	PCT-784	LOC-784	CTIN-784-16	CTES-784-16	GP-784-16	6.8
16	ST485 16P/S	1÷1.5	18÷16	CRT-784/1	PCT-784	LOC-784	CTIN-784-16	CTES-784-16	GP-784-16	6.3
16	ST485 16-08P/S	0.15÷0.2	26÷24	CRT-784/1	PCT-784	LOC-784	CTIN-784-16	CTES-784-16	GP-784-16	6.3
16	ST485 16-12P/S	0.15÷0.75	20	CRT-784/1	PCT-784	LOC-784	CTIN-784-16	CTES-784-16	GP-784-16	6.3
16	ST485 16-13P/S	0.15÷0.6	26÷20	CRT-784/1	PCT-784	LOC-784	CTIN-784-18	CTES-784-16	GP-784-16	6.3
16	ST485 16-14P/S	0.75	18	CRT-784/1	PCT-784	LOC-784	CTIN-784-18	CTES-784-16	GP-784-16	6.3
16	ST485 16-15P/S	0.75÷1	18	CRT-784/1	PCT-784	LOC-784	CTIN-784-16	CTES-784-16	GP-784-16	6.3
16	ST485 16-20P/S	1÷2	18÷14	CRT-784/1	PCT-784	LOC-784	CTIN-784-16	CTES-784-16	GP-784-16	6.3
16	ST485 16-26P/S	2.5÷3	12	CRT-784/1	PCT-784	LOC-784	CTIN-784-16	CTES-784-16	GP-784-16	6.8
12	ST485 12-11P/S	0.5	22-20	**	**	**	**	**	**	8.3
12	ST485 12-12P/S	0.15÷0.75	20	CRT-784/1	PCT-784	LOC-784	CTIN-784-16	CTES-784-12	GP-784-12	8.3
12	ST485 12-15P/S	0.75÷1	18	CRT-784/1	PCT-784	LOC-784	CTIN-784-16	CTES-784-12	GP-784-12	8.3
12	ST485 12-20P/S	1÷2	18÷14	CRT-784/1	PCT-784	LOC-784	CTIN-784-12	CTES-784-12	GP-784-12	6.5
12	ST485 12-22P/S	2.5	-	CRT-784/1	PCT-784	LOC-784	CTIN-784-12	CTES-784-12	GP-784-12	8.3
12	ST485 12P/S	3	12	CRT-784/1	PCT-784	LOC-784	CTIN-784-12	CTES-784-12	GP-784-12	8.3
12	ST485 12-30P/S	4	-	CRT-784/1	PCT-784-A	LOC-784	CTIN-784-12/1	CTES-784-12	GP-784-12	8.3
12	ST485 12-38P/S	6	-	CRT-784/1	PCT-784-A	LOC-784	CTIN-784-12/1	CTES-784-12	GP-784-12	8
8	ST485 8P/S	-	8	CRT-HT45	-	CDI-ME2	CTIN-784-8	CTES-784-8	-	12
8	ST485 8-15P/S	1	18	**	-	**	**	**	-	**
8	ST485 8-18P/S	1÷2	18÷14	**	-	**	**	**	-	**
8	ST485 8-22P/S	2.5	-	CRT-HT45	-	CDI-VS61137	CTIN-784-8	CTES-784-8	-	12
8	ST485 8-26P/S	3	12	**	-	-	-	-	-	**
8	ST485 8-30P/S	4	-	CRT-HT45	-	CDI-ME1	CTIN-784-8	CTES-784-8	-	8
8	ST485 8-38P/S	6	10	CRT-HT45	-	CDI-ME2	CTIN-784-8	CTES-784-8	-	12
8	ST485 8-50P/S	10	-	CRT-HT45	-	CDI-ME2	CTIN-784-8	CTES-784-8	-	12
4	ST485 4P/S	22	4	CRT-HT45	-	CDI-ME5	CTIN-784-4	CTES-784-4	-	12
4	ST485 4-26P/S	3	-	**	-	**	**	**	-	**
4	ST485 4-30P/S	4	-	**	-	**	**	**	-	**
4	ST485 4-38P/S	6	10	CRT-HT45	-	CDI-ME2	CTIN-784-4	CTES-784-4	-	12
4	ST485 4-50P/S	10	-	CRT-HT45	-	CDI-ME2	CTIN-784-4	CTES-784-4	-	12
4	ST485 4-58P/S	-	6	CRT-HT45	-	CDI-ME3	CTIN-784-4	CTES-784-4	-	12
4	ST485 4-62P/S	16	-	CRT-HT45	-	CDI-ME5	CTIN-784-4	CTES-784-4	-	12
4	ST485 4-78P/S	25	-	CRT-HT45	-	CDI-ME5	CTIN-784-4	CTES-784-4	-	12
4	ST485 4-90P/S	35	2	CRT-HT45	-	CDI-ME7	**	CTES-784-4	-	14
0	ST485 0P/S	53	0	CRT-HT45	-	CDI-ME14	CTIN-784-0	CTES-784-0	-	14
0	ST485 0-45P/S	-	8	CRT-HT45	-	CDI-ME2	CTIN-784-0	CTES-784-0	-	12
0	ST485 0-50P/S	10	-	CRT-HT45	**	CDI-ME2	**	CTES-784-0	**	12
0	ST485 0-58P/S	-	6	**	**	**	**	**	**	14
0	ST485 0-62P/S	16	-	CRT-HT45	**	CDI-ME5	**	**	**	12
0	ST485 0-78P/S	25	-	CRT-HT45	-	CDI-ME5	CTIN-784-0	CTES-784-0	-	14
0	ST485 0-80P/S	-	3	**	**	**	**	**	-	14
0	ST485 0-90P/S	35	2	CRT-HT45	-	CDI-ME14	CTIN-784-0	CTES-784-0	-	14
0	ST485 0-107P/S	50	-	CRT-HT45	-	CDI-ME14	CTIN-784-0	CTES-784-0	-	14.3
0	ST485 0-135P/S	67.4	2/0	**	**	**	**	**	-	18
4/0	ST485 4/0-115P/S	53	0	CRT-HT45	-	CDI-ME14	**	CTES-784-4/0	-	**
4/0	ST485 4/0-135P/S	67.4	2/0	**	-	-	**	CTES-784-4/0	-	**
4/0	ST485 4/0-144P/S	70	-	CRT-HT120	-	CDI-ME24C	**	CTES-784-4/0	-	**
4/0	ST485 4/0-155P/S	95	-	CRT-HT120	-	CDI-ME24C	**	CTES-784-4/0	-	**
4/0	ST485 4/0P/S	107÷120	4/0	CRT-HT120	-	CDI-ME29C	**	CTES-784-4/0	-	**

** On request (please consult our Sales Office)

Contact ST Whit Louver Crimp Tools

CVS-CVB-CVBS-CVBSG-CVBR-GVJ (For Rubber Insert)

Contact size	Short Description	mm ² section	AWG section	Manual crimp tool	Pneumatic crimp tool	Locator /Die	Insertion tool	Removal tool	Guide pin	Stripping length mm
8L	ST485 8L-17P/S	1.5	16	**	**	**	**	**	**	**
8L	ST485 8L-23P/S	2.5	-	**	**	**	**	**	**	**
8L	ST485 8L-35P/S	6	10	**	**	**	**	**	**	**
8L	ST485 8L-46P/S	10	-	**	**	**	**	**	**	**
0L	ST485 0L-62P/S	16	-	**	**	**	**	**	**	**
0L	ST485 0L-76P/S	25	-	**	**	**	**	**	**	**
0L	ST485 0L-89P/S	35	-	**	**	**	**	**	**	**
0L	ST485 0L-105P/S	50	-	**	**	**	**	**	**	**
4/0L	ST485 4/0L-115P/S	53	0	CRT-HT45	-	CDI-ME14	**	CTES-784-4/0	-	**
4/0L	ST485 4/0L-135P/S**	67.4	2/0	**	-	-	**	CTES-784-4/0	-	**
4/0L	ST485 4/0L-144P/S	70	-	CRT-HT120	-	CDI-ME24C	**	CTES-784-4/0	-	**
4/0L	ST485 4/0L-155P/S	95	-	CRT-HT120	-	CDI-ME24C	**	CTES-784-4/0	-	**
4/0L	ST485 4/0LP/S	107÷120	4/0	CRT-HT120	-	CDI-ME29C	**	CTES-784-4/0	-	**

** On request (please consult our Sales Office)



Removal tool KTES-784

Contact KT Crimp tools

GVJ (For Thermoplastic Insert)

Contact size	Short Description	mm ² section	AWG section	Manual crimp tool	Pneumatic crimp tool	Locator /Die	Removal tool	Tool To Close Retention Spring	Stripping length mm
16	KT485 16-13P/S**	0.15÷0.6	26÷20	CRT-784/1	PCT-784	LOC-KVBS-784	KTES-784-16	-	9.5
16	KT485 16-12P/S	0.5÷0.75	-	CRT-784/1	PCT-784	LOC-KVBS-784	KTES-784-16	-	9.5
16	KT485 16-20P/S	1÷2	18÷14	CRT-784/1	PCT-784	LOC-KVBS-784	KTES-784-16	-	9.5
16	KT485 16-26P/S	2.5÷3	-	CRT-784/1	PCT-784	LOC-KVBS-784	KTES-784-16	-	9.5
12	KT485 12-12P/S	0.6	20	CRT-784/1	PCT-784	LOC-KVBS-784	KTES-784-12	RS-784-12	9.5
12	KT485 12-20P/S	1÷2	18÷14	CRT-784/1	PCT-784	LOC-KVBS-784	KTES-784-12	RS-784-12	9.5
12	KT485 12-26P/S**	2.5÷3	-	CRT-784/1	PCT-784	LOC-KVBS-784	KTES-784-12	RS-784-12	9.5
12	KT485 12-30P/S	4	-	CRT-784/1	PCT-784	LOC-KVBS-784	KTES-784-12	RS-784-12	9.5
12	KT485 12-38P/S	6	-	CRT-784/1	PCT-784A	LOC-KVBS-784	KTES-784-12	RS-784-12	9.5
8	KT485 8-15P/S	1	-	CRT-HT45	-	**	KTES-784-8	-	12
8	KT485 8-22P/S	2.5	-	CRT-HT45	-	CDI-VS61137	**	-	13.5
8	KT485 8-30P/S**	4	-	CRT-HT45	-	**	KTES-784-8	-	13.5
8	KT485 8-38P/S	6	-	CRT-HT45	-	CDI-VS61138	KTES-784-8	-	13.5
8	KT485 8-50P/S**	10	-	CRT-HT45	-	-	**	-	13.5

Contact KT Whit Louver Crimp tools

GVJ (For Thermoplastic Insert)

Contact size	Short Description	mm ² section	AWG section	Manual crimp tool	Pneumatic crimp tool	Locator /Die	Removal tool	Tool To Close Retention Spring	Stripping length mm
4/0L	KT485 4/0L-115S	53	0	CRT-HT45	-	CDI-ME14	CTES-784-4/0	-	**
4/0L	KT485 4/0L-144S	70	-	CRT-HT120	-	CDI-ME24C	CTES-784-4/0	-	**
4/0L	KT485 4/0L-155S	95	-	CRT-HT120	-	CDI-ME24C	CTES-784-4/0	-	**
4/0L	KT485 4/0L-S	107÷120	4/0	CRT-HT120	-	CDI-ME29C	CTES-784-4/0	-	**

** On request (please consult our Sales Office)

Tools

Connector Assembly

Pipe Wrench

- With exchangeable plastic jaws scratchproof (for treated surfaces)
- For connectors and couplings with screw
- Ideal for tightening and loosening backshell screw connections, plastic pipe fittings and round union nuts connection
- For gentle loosening of backshell
- 25 adjustment positions, box-joint design
- Ergonomic handle geometry
- Pliers chrome plated, handles with non-slip plastic coating



Part Number	Short Description	Tool	L mm	Weight g	Working Capacity Ø	Adjustment positions	Material	Handle Type
VS610074	SW-KN1075	Pipe Wrench	250	355	10 - 75 Ø mm	25	Chrome Vanadium Electric Steel	Plastic

Strap Wrenches

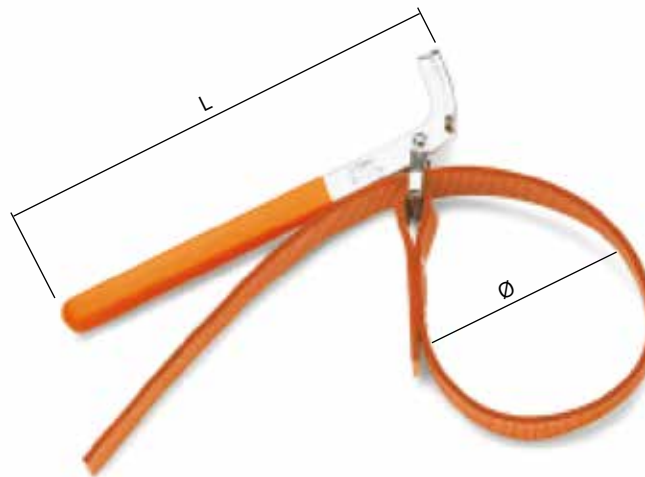

Part Number	Short Description	Tool	L mm	Ø max mm	Weight g
VS610073	SW-BT1490-1	Strap Wrenches	225	160	290

Index

Product Selection Guide - Index	3
Part number explanation	4
General Characteristics	8
CVS - General Characteristics	9
CVB - General Characteristics	10
CVBS - General Characteristics	11
CVBSG - General Characteristics	12
CVBR - General Characteristics	13
GVJ - General Characteristics	14
Circular Connectors	15
General Characteristics - Shells - Shielding characteristics	16
General Characteristics - Shells - Material and Finish	17
General Characteristics - Inserts	18
General Characteristics - Rated Current and Rated Voltage	19
General Characteristics - Contacts - electrical characteristics	20
General Characteristics	21
Contacts - Part number explanation	22
Insulating Inserts And Grommets - Part number explanation	23
Insulating Inserts and Grommets - List by Shell size	50
Insulating Inserts and Grommets - List by contacts total quantity	55
Alternate Insert Positions	60
Connector - Shell	66
Connector Class - Backshell Characteristics	68
CVBS - Bayonet Connector with protected mating ramps - Shell - Backshell	69
Front Mounting Receptacle (00) with Backshell Class (A - DA - RA)	70
Front Mounting Receptacle (00) with Backshell Class (LA - LDA - LRA)	72
Front Mounting Receptacle (00) with Backshell Class (AF - F)	74
Front Mounting Receptacle (00) with Backshell Class (LAF - LF)	76
Front Mounting Receptacle (00) with Backshell Class (AC - ACF)	78
Front Mounting Receptacle (00) with Backshell Class (ACB)	80
Front Mounting Receptacle (00) with Backshell Class (LAC - LACF)	82
Front Mounting Receptacle (00) with Backshell Class (AB)	84
Front Mounting Receptacle (00) with Backshell Class (ASF)	86
Front Mounting Receptacle (00) with Backshell Class (DA..M - RA..M DA..PG - RA..PG)	88
Front Mounting Receptacle (00) with Backshell Class (DA..MH - RA..MH DA..PH - RA..PH)	90
Front Mounting Receptacle (00) with Backshell Class (AR - R)	92
Front Mounting Receptacle (00) with Backshell Class (AG - G)	94
Front Mounting Receptacle (00) with Backshell Class (AG2 - G2)	96
Front Mounting Receptacle (00) with Backshell Class (ASB1 - SB1)	98
Front Mounting Receptacle (00) with Backshell Class (AGV - GV)	100
Front Mounting Receptacle (00) with Backshell Class (SB)	102
Front Mounting Receptacle (020) without Accessories (To be purchased separately)	104
Front Mounting Receptacle (02 - 02A - 02R) unable to Accept Rear Accessories	106
Rear Mounting Receptacle (030) without Accessories (To be purchased separately)	108
Rear Mounting Receptacle (030) with Backshell Class (A - DA - RA)	110
Rear Mounting Receptacle (030) with Backshell Class (AF - F)	112
Rear Mounting Receptacle (030) with Backshell Class (AC - ACF)	114
Rear Mounting Receptacle (030) with Backshell Class (DA..M - RA..M)	116
Rear Mounting Receptacle (030) with Backshell Class (AR - R)	118
Rear Mounting Receptacle (030) with Backshell Class (AG - G)	120
Rear Mounting Receptacle (030) with Backshell Class (AST - ST)	122

Index

Rear Mounting Receptacle (030) with Backshell Class (AST..M - ST..M)	124
Rear Mounting Receptacle (030) with Backshell Class (AST..FS - ST..FS)	126
Rear Mounting Receptacle (03 - 03A - 03R) unable to accept Rear Accessories	128
In-Line Receptacle (01) with Backshell Class (A - DA - RA)	130
In-Line Receptacle (01) with Backshell Class (LA - LDA - LRA)	132
In-Line Receptacle (01) with Backshell Class (AF - F)	134
In-Line Receptacle (01) with Backshell Class (LAF - LF)	136
In-Line Receptacle (01) with Backshell Class (AC - ACF)	138
In-Line Receptacle (01) with Backshell Class (ACB)	140
In-Line Receptacle (01) with Backshell Class (LAC - LACF)	142
In-Line Receptacle (01) with Backshell Class (AB)	144
In-Line Receptacle (01) with Backshell Class (ASF)	146
In-Line Receptacle (01) with Backshell Class (DA...M - RA...M - DA...PG - RA...PG)	148
In-Line Receptacle (01) with Backshell Class (DA...MH - RA...MH - DA...PH - RA...PH)	150
In-Line Receptacle (01) with Backshell Class (AR - R)	152
In-Line Receptacle (01) with Backshell Class (AG - G)	154
In-Line Receptacle (01) with Backshell Class (AG2 - G2)	156
In-Line Receptacle (01) with Backshell Class (ASB1 - SB1)	158
In-Line Receptacle (01) with Backshell Class (AGV - GV)	160
In-Line Receptacle (01) with Backshell Class (SB)	162
Rear Mounting Receptacle (07/07R) unable to accept Rear Accessories	164
Rear Mounting Receptacle (070) without Accessories (To be purchased separately)	166
Plug Connector (06) with Backshell Class (A - DA - RA)	168
Plug Connector (06) with Backshell Class (LA - LDA - LRA)	170
Plug Connector (06) with Backshell Class (AF - F)	172
Plug Connector (06) with Backshell Class (LAF - LF)	174
Plug Connector (06) with Backshell Class (AC - ACF)	176
Plug Connector (06) with Backshell Class (ACB)	178
Plug Connector (06) with Backshell Class (LAC - LACF)	180
Plug Connector (06) with Backshell Class (AB)	182
Plug Connector (06) with Backshell Class (ASF)	184
Plug Connector (06) with Backshell Class (DA..M - RA..M DA..PG - RA..PG)	186
Plug Connector (06) with Backshell Class (DA..MH - RA..MH DA..PH - RA..PH)	188
Plug Connector (06) with Backshell Class (AR - R)	190
Plug Connector (06) with Backshell Class (AG - G)	192
Plug Connector (06) with Backshell Class (DA..FS - RA..FS)	194
Plug Connector (06) with Backshell Class (DA..MTG - RA..MTG)	196
Plug Connector (06) with Backshell Class (AG2 - G2)	198
Plug Connector (06) with Backshell Class (AWN - WN)	200
Plug Connector (96) with Backshell Class (AC - ACF)	202
Plug Connector (96) with Backshell Class (DA..M - RA..M DA..PG - RA..PG)	204
Plug Connector (96) with Backshell Class (DA..FS - RA..FS)	206
Plug Connector (96) with Backshell Class (DA..MTG - RA..MTG)	208
Plug Connector (96) with Backshell Class (AG2 - G2)	210
Plug Connector (96) with Backshell Class (ASB1 - SB1)	212
Plug Connector (96) with Backshell Class (AGV - GV)	214
Plug Connector (96) with Backshell Class (SB)	216
Plug Connector (96) with Backshell Class (AMK - MK)	218
Plug Connector (08) with 90° Elbow Class (A - DA - RA)	220
Plug Connector (08) with 90° Elbow Class (AF - F)	222
Plug Connector (08) with 90° Elbow Class (AC - ACF)	224

Index

Plug Connector (08) with 90° Elbow Class (ACB)	226
Plug Connector (08) with 90° Elbow Class (DA...M - RA...M - DA...PG - RA...PG)	228
Plug Connector (98) with 90° Elbow Class (AC - ACF)	230
Plug Connector (98) with 90° Elbow Class (DA...M - RA...M - DA...PG - RA...PG)	232
Plug Connector with heavy duty coupling nut (65) with Backshell Class (A - DA - RA)	234
Plug Connector with rubber covered coupling nut (06..GG) with Backshell Class (A - DA - RA)	236
Plug Connector with rubber covered coupling nut (06..GG) with Backshell Class (AC - ACF)	238
Plug Connector with rubber covered coupling nut (06..GG) with Backshell Class (DA..M - RA..M DA..PG - RA..PG)	240
Plug Connector with rubber covered coupling nut (96..GG) with Backshell Class (A - DA - RA)	242
Plug Connector with rubber covered coupling nut (08..GG) with 90° Elbow Class (A - DA - RA)	244
Plug Connector with rubber covered coupling nut (08..GG) with 90° Elbow Class (AC - ACF)	246
Plug Connector with rubber covered coupling nut (98..GG) with 90° Elbow Class (A - DA - RA)	248
Plug Connector with rubber covered coupling nut (short version) (61..GG) with Backshell Class (A - DA - RA)	250
Plug Connector with rubber covered coupling nut (short version) (61..GG) with Backshell Class (AC - ACF)	252
Plug Connector with rubber covered coupling nut (short version) (61..GG) with Backshell Class (DA..M - RA..M DA..PG - RA..PG)	254
Plug Connector with rubber covered coupling nut (short version) (61..GG) with Backshell Class (AST - ST)	256
Plug Connector with rubber covered coupling nut (short version) (61..GG) with Backshell Class (AST..M - ST..M)	258
Plug Connector with rubber covered coupling nut (short version) (61..GG) with Backshell Class (AST..FS - ST..FS)	260
Plug Connector with rubber covered coupling nut (short version) (81..GG) with 90° Elbow Class (A - DA - RA)	262
Plug Connector with rubber covered coupling nut (short version) (81..GG) with 90° Elbow Class (AST..M - ST..M)	264
Front Mounting Receptacle (26) unable to Accept Rear Accessories	266
Front Mounting Receptacle, heavy duty coupling nut (265) unable to Accept Rear Accessories	268
Through-Bulkhead Connector (TB)	270
Dummy Receptacle Connector (05)	272
CVBSG - Bayonet Connector with external insulated coating - Shell - Backshell	275
Front Mounting Receptacle (00) with Backshell Class (DA...M - RA...M)	276
Rear Mounting Receptacle (030) with Backshell Class (DA...M - RA...M)	278
Rear Mounting Receptacle (030) with Backshell Class (DA...FS - RA...FS)	280
Rear Mounting Receptacle (030) with Backshell Class (DA...MTG - RA...MTG)	282
Plug Connector (06) with Backshell Class (DAM - RAM)	284
Plug Connector (06) with Backshell Class (DA..M - RA..M)	286
Plug Connector (06) with Backshell Class (DA..FS - RA..FS)	288
Plug Connector (06) with Backshell Class (DA..MTG - RA..MTG)	290
Plug Connector (06) with Backshell Class (AMK - MK)	292
Plug Connector (96) with Backshell Class (AMK - MK)	294
Plug Connector (08) with 90° Elbow Class (DAM - RAM)	296
Plug Connector (08) with 90° Elbow Class (DA..M - RA..M)	298
Plug Connector (08) with 90° Elbow Class (DA..FS - RA..FS)	300
Plug Connector (08) with 90° Elbow Class (DA..MTG - RA..MTG)	302
Plug Connector with rubber covered coupling nut (short version) (61) with Backshell Class (DAM - RAM)	304
Plug Connector with rubber covered coupling nut (short version) (61) with Backshell Class (DA..M - RA..M)	306
Plug Connector with rubber covered coupling nut (short version) (81) with 90° Elbow Class (DA..M - RA..M)	308
CVBR - Bayonet Connector roller studs - for harsh applications - Shell - Backshell	311
Plug Connector (06) with Backshell Class (A - DA - RA)	312
Plug Connector (06) with Backshell Class (AF - F)	314
Plug Connector (08) with 90° Elbow Class (A - DA - RA)	316
GVJ - Oversize Bayonet Connector - Shell - Backshell	319
Front Mounting Receptacle (00) with Backshell Class (A - DA - RA)	320
Front Mounting Receptacle (00) with Backshell Class (AC - ACF)	322
Front Mounting Receptacle (00) with Backshell Class (DA..M - RA..M DA..PG - RA..PG)	324
Front Mounting Receptacle (020) without Accessories (To be purchased separately)	326

Index

Rear Mounting Receptacle (038) with 90° Elbow Class (A - DA - RA)	328
Rear Mounting Receptacle (038) with 90° Elbow Class (AC - ACF)	330
Rear Mounting Receptacle (038) with 90° Elbow Class (DA..M - RA..M)	332
Plug Connector with rubber covered coupling nut (06) with Backshell Class (A - DA - RA)	334
Plug Connector with rubber covered coupling nut (06) with Backshell Class (AC - ACF)	336
Plug Connector with rubber covered coupling nut (06) with Backshell Class (DA..M - RA..M DA..PG - RA..PG)	338
Plug Connector with rubber covered coupling nut (08) with 90° Elbow Class (A - DA - RA)	340
Plug Connector with rubber covered coupling nut (08) with 90° Elbow Class (AC - ACF)	342
Plug Connector with rubber covered coupling nut (08) with 90° Elbow Class (DA...M - RA...M)	344
GVJG - Oversize Bayonet Connector with external insulated coating	346
Plug Connector with rubber covered coupling nut (06) with Backshell Class (DA..M - RA..M)	346
Connector Shell - Receptacle mounting holes option	348
Connector Shell - Panel drilling dimensions	349
Connector Shell - Mounting panel characteristics	350
Contacts - Part number explanation	351
Solder Contacts - ST - For Rubber insert	352
Crimp Contacts - ST - For Rubber insert	354
Crimp Contacts with Louver - ST - For Rubber insert	358
Crimp Contacts with Touch Proof - ST - For Rubber insert	359
Crimp Contacts Close Entry - ST - For Rubber insert	360
Contacts FMLB First Mate Last Break - ST - For Rubber insert	361
Contacts AO Advance Opening Contacts - ST - For Rubber insert	362
ST Contacts - for Lug	363
KT Contacts - for thermoplastics inserts	364
KT Contacts with Louver - for thermoplastics inserts	365
Crimp Adapters	366
Coaxial Contacts - For Rubber insert	367
Thermocouple Contacts	368
Thermocouple Contacts - Solder	370
Thermocouple Contacts - Crimp	371
PCB Tail - Contacts	372
Accessories For Connectors	373
Caps for Bayonet Connectors	374
Caps for Threaded Connectors	376
Protective Plastic Dust Caps	378
Connector Closure Plate	379
Connector Mounting Gaskets	380
G3 Shielded Gaskets	381
Cable-Clamps A type	382
Bushing for Cable-Clamps A type	383
Cable-Clamps C type	384
Bushing for Cable-Clamps C type	385
Cable Glands - PG or metric threaded	386
Contacts hole plugs for inserts	388
Contact Crimp Tools	389
Contact ST Crimp Tools	390
Contact KT Crimp tools	391
Tools	392

Information regarding the use of the product within recommended safety limits

To use the connectors described in this catalogue according to the necessary safety requirements we suggest you apply the following criteria:

- use the connectors and connected cables within their electrical and environmental limits
- follow the characteristics of each version (shell, class and type of strain relief) and carefully choose the appropriate connector for the required use
- make sure to respect the procedures regarding the correct assembly of connectors and the crimping of contacts
- any connector damaged during shipment, storage, assembly or use should be replaced
- never uncouple the connectors when under power
- always protect the parts against shock when the circuit is under power
- always check the circuit before putting it under power
- consult Radiall VanSystem Srl if in doubt
- the user must take final responsibility for electrical safety Radiall VanSystem Srl reserves the right to amend the specifications of this catalogue without issuing prior notice.

For the instructions concerning assembly and crimping of contacts please consult the appropriate tools manuals.

We recommend to respect the following general rules:

- to be used always the tools recommended by Radiall VanSystem's catalogue or manuals
- to be applied the suggested norms for tool maintenance and calibration

DO NOT USE ALTERNATIVE GREASES OR OILS which could damage the insert and affect the functionality of the connector. Radiall VanSystem Srl reserves the right to amend the specifications of this catalogue without issuing prior notice.

The data defined in this document are given as an indication. In the effort to improve our products, we reserve the right to make any change judged necessary.



www.radiall.com

FRANCE

RADIALL S.A.
Tel +33149353535
info@radiall.com



www.vansystem.eu

ITALY

Radiall VanSystem S.r.l.
Tel. +39023569931
info.vansystem@radiall.com

2021 EDITION
08.2021

050.RAIL019
PRINTED IN ITALY