



EFS[®] MARINE ASystem

Manuale
Tecnico
Technical manual

 Italiano  Inglese

Rev. 0_2020 - Doc. N° 32

ELECTRIX

DISTRIBUZIONE srl

■ ■ Sistema di protezione al fuoco in classe A su paratia (MED NR.288119CS/002) Attraversamenti cavi elettrici secondo IMO Res. MSC. 307(88)-(2010 FTP Code) - IMO MSC.1/Circ. 1488

🇬🇧 Class A fire protection system on bulkhead (MED NR.288119CS/002) penetration through electric cable according to IMO Res. MSC. 307(88)-(2010 FTP Code) - IMO MSC.1/Circ. 1488

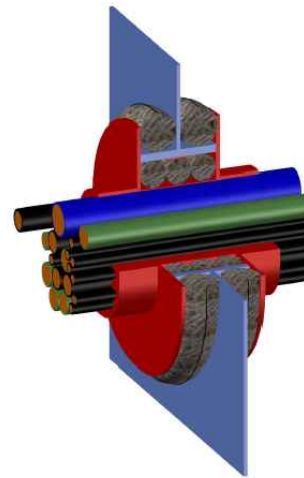

■ ■ Applicazioni	🇬🇧 Application
<ul style="list-style-type: none"> ● Passaggi di cavi elettrici (singoli o fascio di cavi) ● Paratie in acciaio ● Applicabile solo in presenza di collare strutturale già saldato ● Dimensioni transiti da 240x220mm fino a 500x280mm 	<ul style="list-style-type: none"> ● Transits of electric cables (single or bundle of cables) ● Steel bulkheads ● Installation only with welded collar ● Transits dimensions from 240x220mm up to 500x280mm

■ ■ Vantaggi	🇬🇧 Advantages
<ul style="list-style-type: none"> ● Facilità di installazione ● Facilità di refitting ● Minimo scarto ● Impermeabile ● A0 - A60 max riempimento cavi ammesso non inferiore al 40% ● Sistema testato in classe A, senza ulteriori coibentazioni 	<ul style="list-style-type: none"> ● Ease of installation ● Ease of refitting ● Minimum wastage ● Waterproof ● A0 - A60 max allowed cable filling not less than 40% ● System tested in class A without using more insulations

DATI TECNICI - KIT / TECHNICAL DATA - KIT

Cordone - Cord

	Descrizione del prodotto - Product description	Packaging	Quantity
	■ ■ Cordone cilindrico, composto da lana minerale, inguainata da un reticolo in fibra di vetro flessibile	da Ø 20mm da Ø 30mm da Ø 50mm da Ø 60mm	bobina da 50m bobina da 50m bobina da 25m bobina da 25m
	🇬🇧 FJ203 is a firestopping backer rod made of rock wool sheathed with flexible glass wires.	from Ø 20mm from Ø 30mm from Ø 50mm from Ø 60mm	coils from 50m coils from 50m coils from 25m coils from 25m

Mastice - Mastic

	■ ■ Descrizione del prodotto	🇬🇧 Product description		
	E' un componente sigillante (fuoco e fumi), ignifugo, autoportante a base d'acqua ed estremamente intumescente. E' un sigillante a base elastomerica e consigliato in zone sottoposte a movimento. Questo prodotto viene applicato con una cartuccia o può essere pompato direttamente dal contenitore, tramite una pompa ad estrusione. Il prodotto può essere riutilizzato se conservato correttamente e non a contatto diretto con l'aria.	It is a one component fire rated sealant, self supporting and smoke seal. It is water based, extremely intumescent. It cures to an elastomeric seal that is suitable where dynamic movement is expected. This product is applied with a conventional caulking gun, extrusion pump, cartridge or can be troweled. The sealant can be reused if correctly storage not in direct contact with air.		
	Confezionamento	Quantità	Packaging	Quantity
Fusto 5 Gal (18,6L) Cartucce 10,3 FL. O.Z. (304 ml)	1 12	Pails 5 Gal (18,6L) Cartridges 10,3 FL. O.Z. (304 ml)	1 12	

 <p>Forbici / Scissors</p>	 <p>Spatola / Spatula</p>	 <p>Tenaglia / Pincer</p>	 <p>Pompa ad estrusione / Pump extrusion</p>
 <p>Scotch / Scotch tape</p>	 <p>Filo di ferro / Wire</p>	 <p>Pistola per pompa / Pump gun</p>	
 <p>Pistola per mastice / Mastic gun</p>	 <p>Guanti / Gloves</p>		

INSTALLAZIONE / INSTALLATION

1

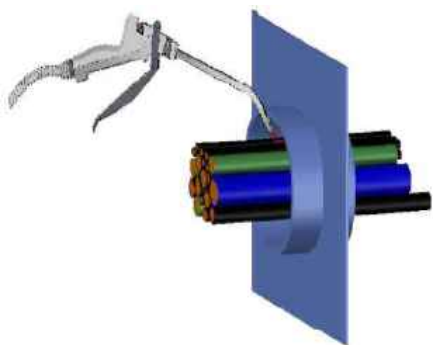

■ ■ Applicare il mastice in più punti all'interno del collare in corrispondenza delle klips, per uno spessore \geq di 1mm

■ ■ Gun, trowel or pump the sealant inside the collar in more point at the clips, for a thickness \geq of 1mm

2

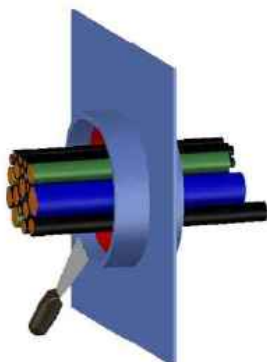

■ ■ Spalmare il mastice con l'aiuto di una spatola

■ ■ Spread the mastic with help of the spatula

INSTALLAZIONE - INSTALLATION

3

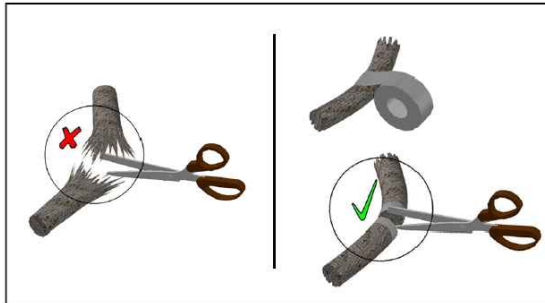
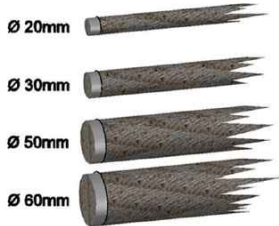

(n.1)

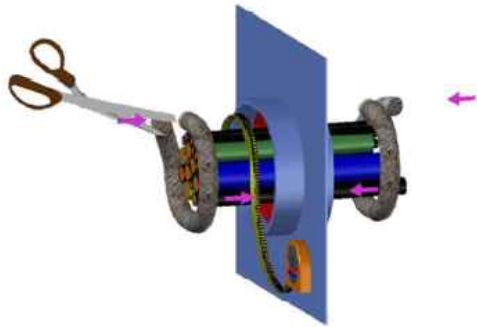

■ ■ In base alla quantità di cavi, e alla dimensione del transit, individuare il diametro adeguato del cordone.

- 1) Misurare il perimetro interno del collare
- 2) Nastrare il cordone nel punto di taglio
- 3) Tagliare il cordone sulla nastratura (fig.1)
- 4) Inserire il cordone all'interno ed avvolgerlo attorno ai cavi per ottenere la chiusura totale del transit

🇬🇧 Depending on the quantity of cables and the size of the transit, identify the correct diameter of the cord.

- 1) Measure the inside perimeter of the collar
- 2) Tape the cord at the cutting point
- 3) Cut the cord (pic.1)
- 4) Put the cord inside and wrap it around the cables to complete close the transit

4

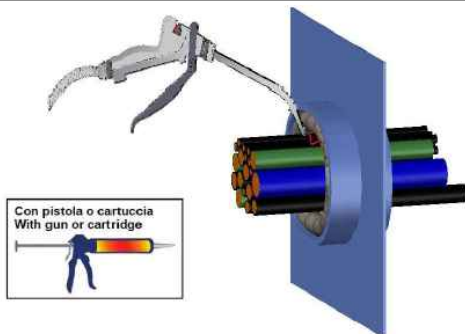

Con pistola o cartuccia
With gun or cartridge

■ ■ Applicare il mastice a riempimento di eventuali interstizi, utilizzando la pistola o cartuccia

🇬🇧 Use the sealant to fill any gaps, with a gun or a cartridge

5

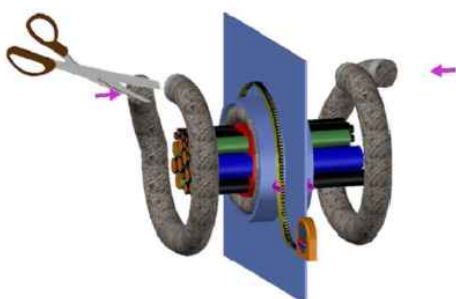

■ ■ 1) Misurare il perimetro esterno del collare
2) Nastrare il cordone
3) Tagliare il cordone nel punto segnato
4) Avvolgere il cordone Ø 50mm sulla parete esterna del collare ambo i lati

🇬🇧 1) Measure the outer perimeter of the collar
2) Tape the cord
3) Cut the cord at the marked point
4) Wrap the cord Ø 50mm on the outer wall of the collar on both sides

INSTALLAZIONE - INSTALLATION

6

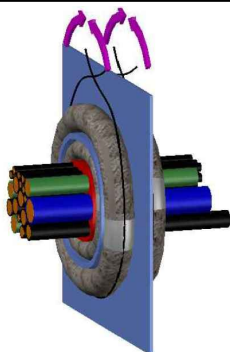

■ ■ Fissare i cordoni con il filo di ferro

■ ■ Secure the cord with iron wire

7

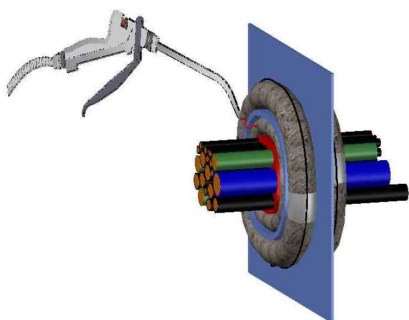

■ ■ Applicare il mastice per coprire tutta la superficie su entrambi i lati del sistema per uno spessore $\geq 3\text{mm}$

■ ■ Put the mastic to cover the entire surface on both side of bulkhead for a tickness of $\geq 3\text{mm}$

8

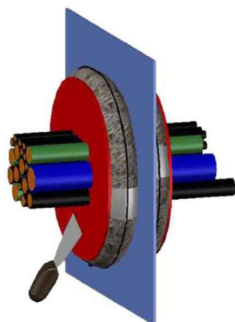

■ ■ Spalmare la superficie del tamponamento con una spatola

■ ■ Trowel the surface of the penetration with a spatula

9

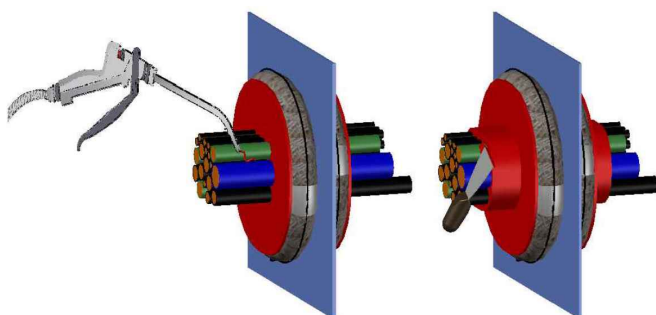

■ ■ Rivestire i cavi con il mastice per una lunghezza di 50mm e spessore \geq di 3mm, su entrambi i lati, usando una pistola o cartuccia, e rifinire la rasatura con l'aiuto di una spatola

■ ■ Coat the cable with mastic for a length of 50mm and thickness \geq di 3mm, on both sides, using a gun or cartridge, and finish the leveling with the help of a spatula



Electrix Distribuzione Srl

Via A. Meucci, 6 - Caselle di Selvazzano PD +39 049 8987111 info@electrixdistribuzione.it

Electrix Distribuzione Srl

Via A. Meucci, 6 - Caselle di Selvazzano PD +39 049 8987111 info@electrixdistribuzione.it